

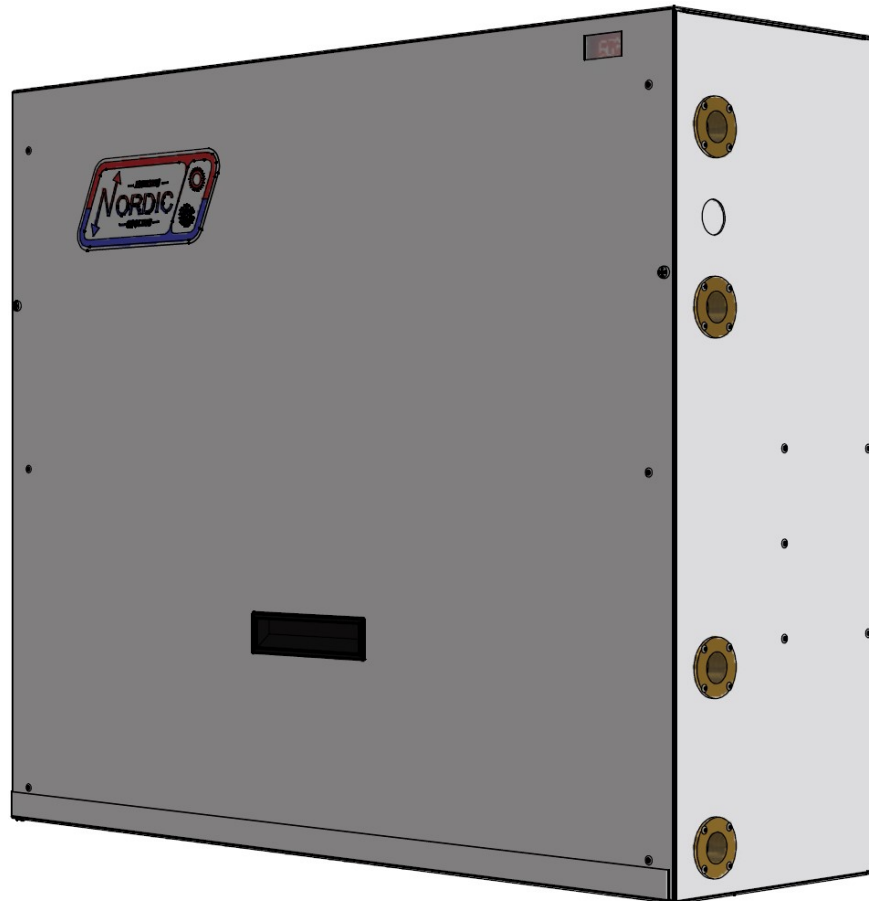

# Engineering Specification

## W-18-HAC-P-\*L-\*P Liquid to Water Heat Pump 60 Hz



Maritime Geothermal Ltd.  
P.O. Box 2555, 170 Plantation Road  
Petitcodiac, NB E4Z 6H4  
(506) 756-8135



info@nordicghp.com  
www.nordicghp.com  
002409SPC-02

# Model Nomenclature

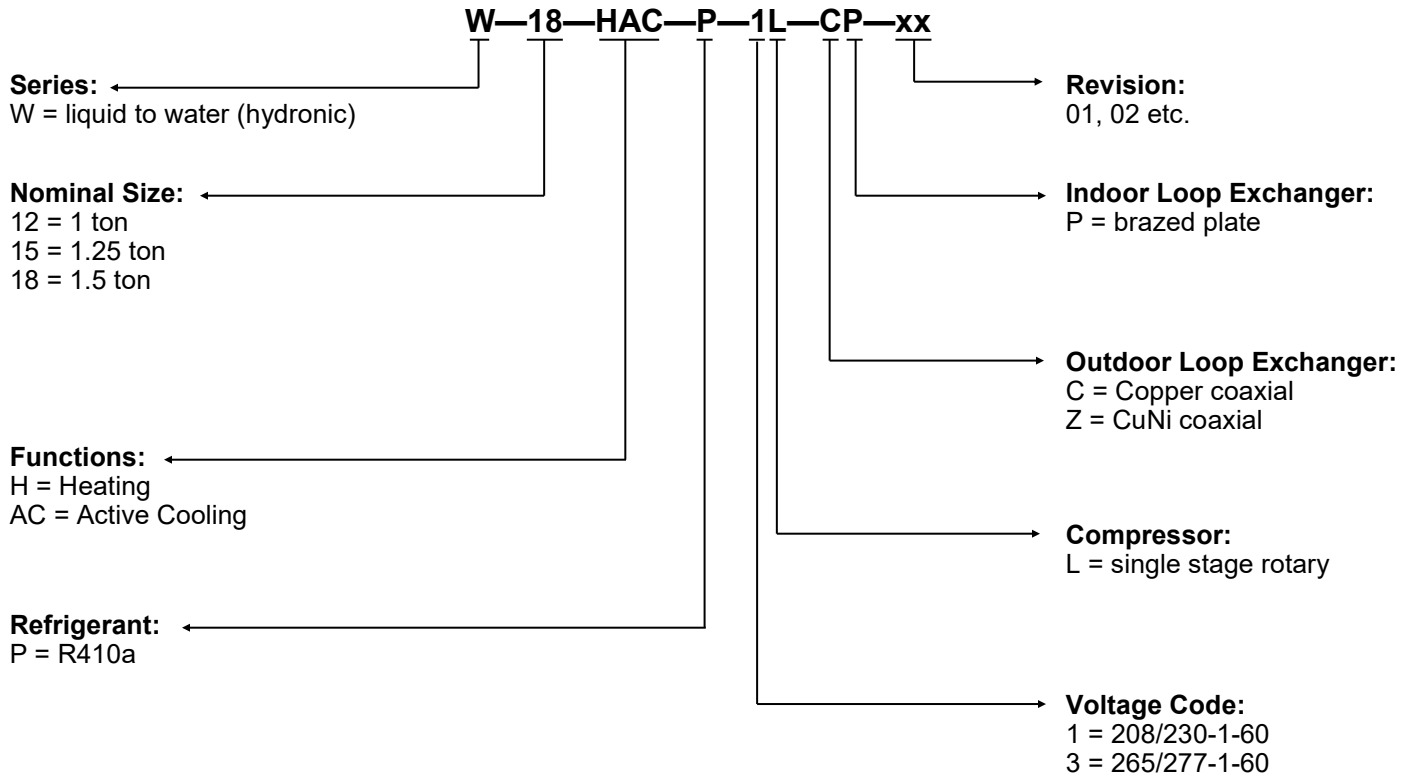

APPLICATION TABLE										
MODEL	FUNCTION	REFRIGERANT	VOLTAGE	COMPRESSOR	OUTDOOR HEAT EXCHANGER	INDOOR HEAT EXCHANGER	REVISIONS			
W-18	HAC	P	1 3	L	C Z	P	02			

This manual applies only to the models and revisions listed in this table.

Maritime Geothermal Ltd. has a continuous improvement policy and reserves the right to modify specification data at any time without prior notice .

# Design Features

---

- Nordic small W-series heat pumps are 1 to 1.5 tons in capacity, making them ideal for single zone or passive house applications
- Built in aquastat with temperature probe for buffer tank, and digital display of water temperature visible through cover
- Although not required, connections are present for an optional external cooling mode aquastat for automatic cooling switchover applications
- TUV certified for safety (CSA 22.2 No 236-05)
- Satin galvanized steel cabinet, wall mounted
- Powder coat finish
- Acoustically insulated cabinet
- All loop/water connections located on right side
- 3/4" brass FPT fittings for loop connections
- One cover for clear access to all components
- Component layout allows easy access for service
- Refrigeration service ports located inside unit (1/4" Schrader)
- Insulated coaxial heat exchanger for outdoor loop, available in copper or cupro-nickel (CuNi)
- Insulated brazed plate heat exchanger for indoor loop, with flow switch standard
- Connection points for outdoor and indoor circulator pump power
- Reliable LG rotary compressor, with built in suction line accumulator
- Dual-grommet-mounted compressor for reduced noise and vibration
- Liquid line filter-dryer
- Liquid line sight glass
- Balanced port thermostatic expansion valve (TXV) with internal bleed
- 4-way reversing valve
- High and low pressure safety controls
- Control board with random start, anti-short cycle timer, auto-retry and permanent lockout mode

# Available Accessories

---

- Cooling mode aquastat for automatic cooling mode switchover systems
- Circulator pump module with loop / unit isolation valves for ground loop applications
- Compressor sound jacket
- 3/4" solenoid water valve & wiring harness for open loop applications

# Design Features

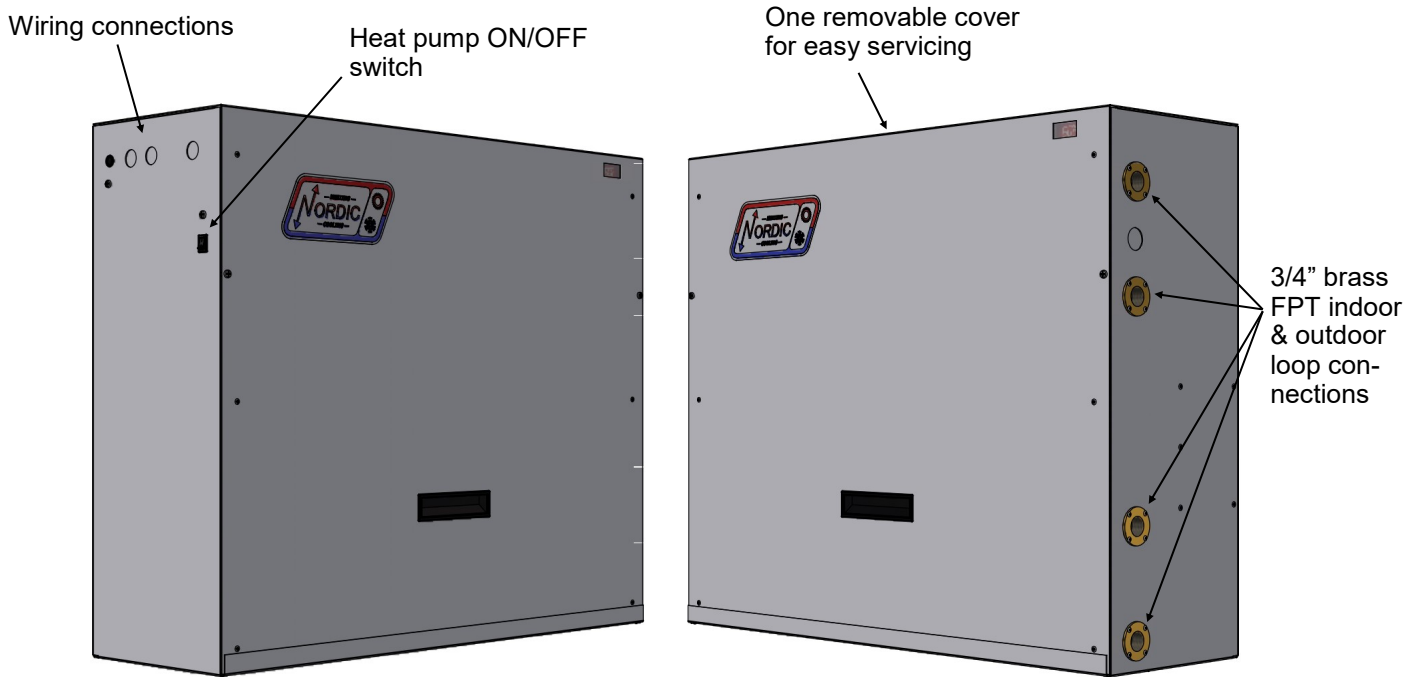
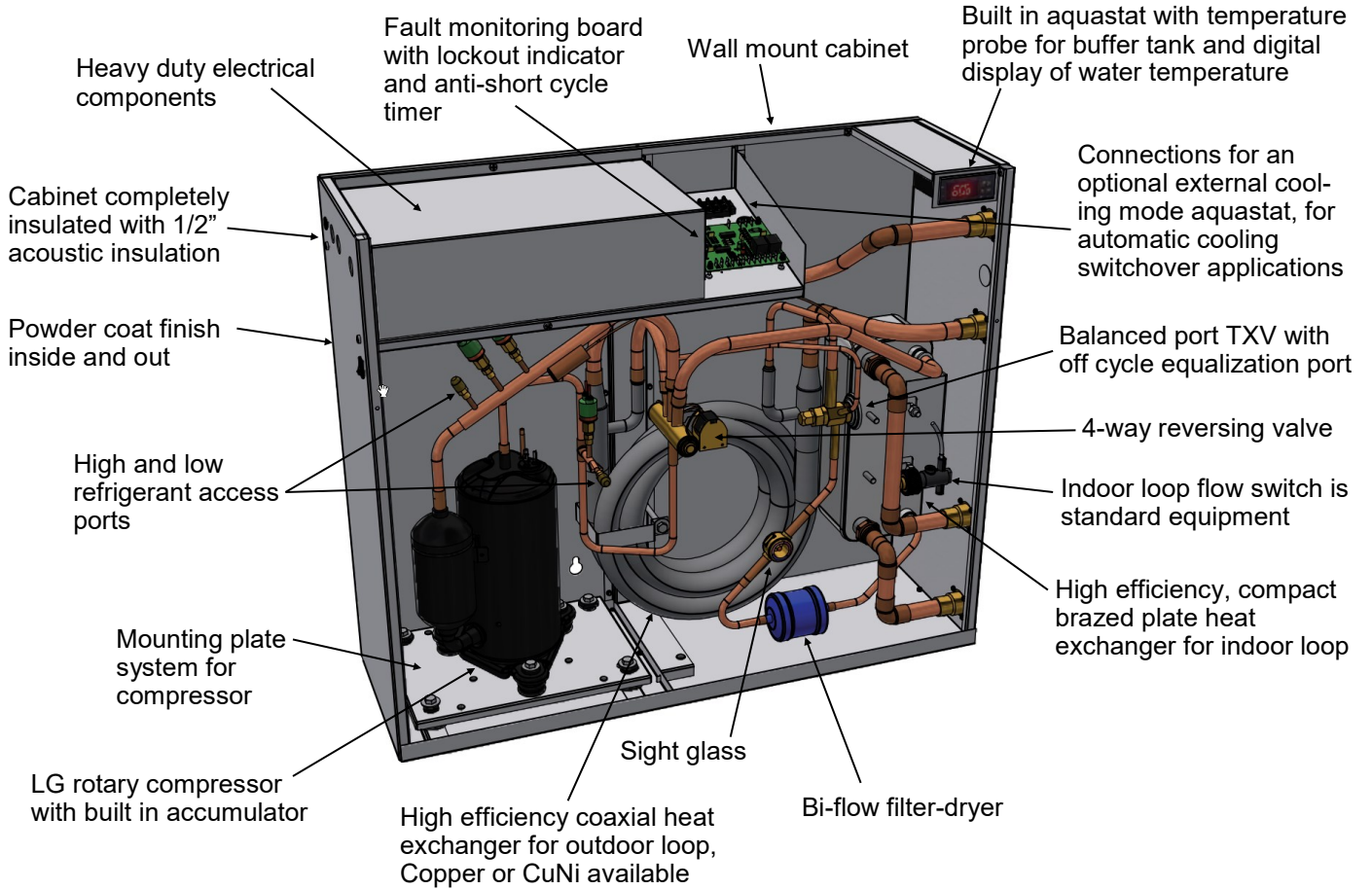

# Dimensions

RECOMMENDED FRONT CLEARANCE:  
**2 FT**

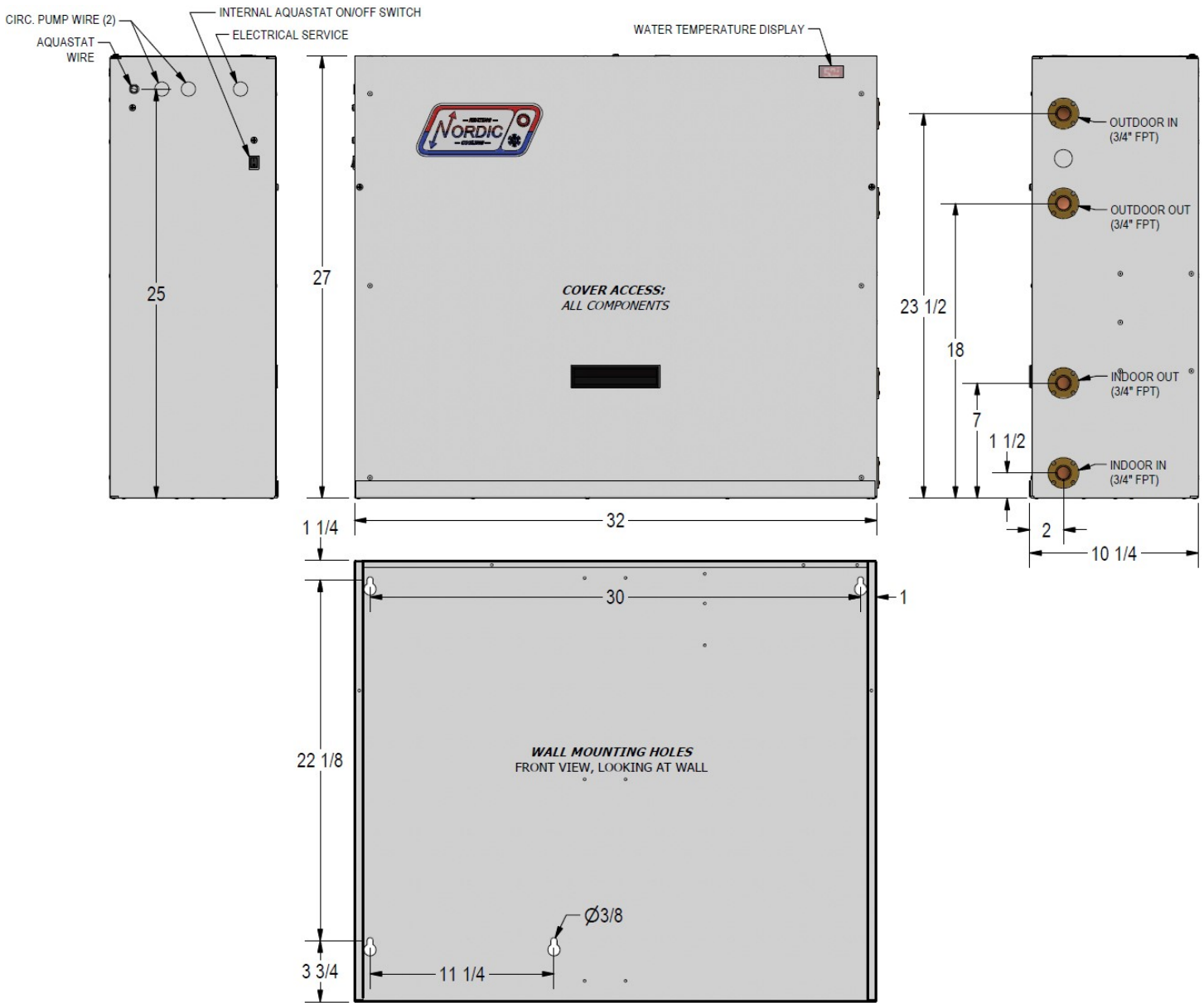

NO BACK OR SIDE CLEARANCES REQUIRED

# Specifications

Electrical Specifications											
Model	Code	Power Supply			Compressor		Circulators	FLA	MCA	Max. Breaker	Min. Wire
		V- $\phi$ -Hz	MIN	MAX	RLA	LRA	Max. A	Amps	Amps	Amps	ga
W-18	1	208/230-1-60	187	253	7.0	38	3.0	10.2	12.0	20	#12-2*
	3	265/277-1-60	226	304	6.0	30	3.0	9.2	10.7	15	#14-2

\* For 208/230-1-60, 1 additional conductor (neutral) is required if connecting 115VAC circulators to the unit.

Shipping Information				
MODEL	WEIGHT lb. (kg)	DIMENSIONS in (cm)		
		L	W	H
W-18	185 (84)	38 (97)	18 (46)	32 (81)

Required Indoor & Outdoor Loop Flow Rate		
MODEL	gpm	L/s
W-18	4.5	0.28

Refrigerant Charge				
MODEL	lb	kg	Refrigerant	Oil Type
W-18	1.5	0.68	R410a	POE

- Oil capacity is marked on the compressor label.  
 - Refrigerant charge is subject to revision; actual charge is indicated on the unit nameplate.

	Loop Pressure Drop Data		INDOOR (water 104°F)		OUTDOOR (water 50°F)		OUTDOOR (15% methanol 32°F)		OUTDOOR (35% prop. glycol 32°F)	
	gpm	L/s	psi	kPa	psi	kPa	psi	kPa	psi	kPa
W-18	2.5	0.16	0.2	1.6	0.8	5	0.9	6	1.4	10
	3	0.19	0.3	2.2	1.1	8	1.2	8	1.8	13
	3.5	0.22	0.4	2.9	1.5	10	1.6	11	2.2	15
	4	0.25	0.5	3.7	1.8	12	2.0	13	2.7	18
	4.5	0.28	0.7	4.6	2.3	16	2.5	17	3.4	23
	5	0.32	0.8	5.5	2.8	19	3.0	21	4.0	28
	5.5	0.35	1.0	6.7	3.5	24	3.8	26	5.0	34

Operating Temperature Limits					
Loop	Mode	Parameter	(°F)	(°C)	Note
Indoor	Heating	Minimum ELT	50	10	Reduce flow if necessary during startup.
	Heating	Maximum LLT	120	49	
	Cooling	Minimum LLT	41	5	Water system (no antifreeze).
	Cooling	Minimum LLT	32	0	Antifreeze system. Adequate freeze protection required.
	Cooling	Maximum ELT	80	27	
Outdoor	Heating	Minimum ELT	39	4	Ground water (open loop) system.
	Heating	Minimum ELT	23	-5	Ground loop system. Adequate freeze protection required.
	Cooling	Minimum ELT	39	4	Ground water (open loop) system.
	Cooling	Minimum ELT	32	0	Ground loop system. Adequate freeze protection required.
	Cooling	Maximum LLT	120	49	

\* Values in this table are for rated liquid flow values.

# Standard Capacity Ratings

Standards C13256-2 / ISO13256-2 / ARI 13256-2

Standard Capacity Ratings - <b>Ground Loop Heating*</b>						60Hz
EWT 104°F (40°C) * 15% Methanol by Weight Ground Loop Fluid					ELT 32°F (0°C)	
Model	Liquid Flow (Outdoor & Indoor)		Input Energy	Capacity		COP <sub>H</sub>
	gpm	L/s	Watts	Btu/hr	kW	W/W
W-18	4.5	0.28	1,235	12,800	3.8	3.0

Standard Capacity Ratings - <b>Ground Loop Cooling*</b>						60Hz	
EWT 53.6°F (12°C) * 15% Methanol by Weight Ground Loop Fluid					ELT 77°F (25°C)		
Model	Liquid Flow (Outdoor & Indoor)		Input Energy	Capacity		COP <sub>C</sub>	EER
	gpm	L/s	Watts	Btu/hr	kW	W/W	Btu/hr/W
W-18	4.5	0.28	1,065	15,100	4.4	4.2	14.3

Standard Capacity Ratings - <b>Ground Water Heating</b>						60Hz
EWT 104°F (40°C)					ELT 50°F (10°C)	
Model	Liquid Flow (Outdoor & Indoor)		Input Energy	Capacity		COP <sub>H</sub>
	gpm	L/s	Watts	Btu/hr	kW	W/W
W-18	4.5	0.28	1,300	16,700	4.9	3.8

Standard Capacity Ratings - <b>Ground Water Cooling</b>						60Hz	
EWT 53.6°F (12°C)					ELT 59°F (15°C)		
Model	Liquid Flow (Outdoor & Indoor)		Input Energy	Capacity		COP <sub>C</sub>	EER
	gpm	L/s	Watts	Btu/hr	kW	W/W	Btu/hr/W
W-18	4.5	0.28	900	17,200	5.0	5.6	19.2

# Performance Tables

W-18-HAC-P-\*L R410a, 60 Hz, GJS151KAA

	OUTDOOR LOOP						ELECTRICAL		INDOOR LOOP						
	ELT (°F)	Evap. Temp.	Flow (gpm)	LLT (°F)	Delta T (°F)	Heat Abs. (Btu/hr)	Compressor Current (A)	Input Power (W)	EWT (°F)	Cond. Temp.	Flow (gpm)	LWT (°F)	Delta T (°F)	Heating (Btu/hr)	COP <sub>H</sub>
<b>HEATING</b>	25	14	4.5	21	4	7,495	6.0	1,183	104	112	4.5	109	5	11,450	2.84
	30	19	4.5	26	4	8,331	6.1	1,217		113	4.5	110	6	12,404	2.99
	35	24	4.5	31	4	9,227	6.2	1,245		113	4.5	110	6	13,396	3.15
	40	29	4.5	35	5	10,198	6.2	1,270		114	4.5	110	6	14,453	3.33
	45	33	4.5	40	5	11,227	6.3	1,287		114	4.5	111	7	15,546	3.54
	50	38	4.5	44	6	12,323	6.4	1,304		115	4.5	111	7	16,700	3.75
	55	43	4.5	49	6	13,503	6.4	1,318		116	4.5	112	8	17,928	3.99
	60	47	4.5	53	7	14,788	6.5	1,328		116	4.5	113	9	19,247	4.25
	25	15	4.5	22	3	6,915	6.5	1,262	115	123	4.5	120	5	11,141	2.59
	30	20	4.5	26	4	7,771	6.6	1,295	115	123	4.5		5	12,111	2.74
	35	24	4.5	31	4	8,655	6.7	1,325	114	123	4.5		6	13,097	2.90
	40	29	4.5	36	4	9,606	6.7	1,350	114	123	4.5		6	14,133	3.07
	45	34	4.5	40	5	10,640	6.8	1,372	113	123	4.5		7	15,248	3.26
	50	39	4.5	45	5	11,733	6.9	1,392	113	123	4.5		7	16,408	3.46
	55	44	4.5	49	6	12,922	6.9	1,408	112	123	4.5		8	17,653	3.67
	60	49	4.5	53	7	14,225	7.0	1,424	112	123	4.5		8	19,010	3.91

	ELT (°F)	Cond. Temp.	Flow (gpm)	LLT (°F)	Delta T (°F)	Heat Rej. (Btu/hr)	Compressor Current (A)	Input Power (W)	EWT (°F)	Evap. Temp.	Flow (gpm)	LWT (°F)	Delta T (°F)	Cooling (Btu/hr)	EER
	<b>COOLING</b>	60	77	4.5	69	9	19,763	4.7	901	54	39	4.5	46	8	17,097
65		82	4.5	74	9	19,382	4.8	933	39		4.5	46	7	16,608	17.8
70		88	4.5	79	9	18,934	5.0	978	40		4.5	46	7	16,006	16.4
75		93	4.5	84	9	18,499	5.2	1,035	40		4.5	47	7	15,377	14.9
80		98	4.5	88	8	18,028	5.4	1,106	41		4.5	47	7	14,671	13.3
85		103	4.5	93	8	17,605	5.7	1,184	41		4.5	47	6	13,983	11.8
90		109	4.5	98	8	17,154	6.0	1,274	42		4.5	48	6	13,226	10.4
95		114	4.5	103	8	16,747	6.3	1,372	43		4.5	48	6	12,483	9.1

METRIC

	OUTDOOR LOOP						ELECTRICAL		INDOOR LOOP						
	ELT (°C)	Evap. Temp.	Flow (L/s)	LLT (°C)	Delta T (°C)	Heat Abs. (W)	Compressor Current (A)	Input Power (W)	EWT (°C)	Cond. Temp.	Flow (L/s)	LWT (°C)	Delta T (°C)	Heating (W)	COP <sub>H</sub>
<b>HEATING (METRIC)</b>	-3.9	-9.8	0.28	-5.8	1.9	2,196	6.0	1,183	40	44.6	0.28	42.8	2.8	3,356	2.84
	-1.1	-7.2	0.28	-3.3	2.2	2,442	6.1	1,217		44.9	0.28	43.1	3.1	3,635	2.99
	1.7	-4.6	0.28	-0.7	2.4	2,704	6.2	1,245		45.2	0.28	43.3	3.3	3,926	3.15
	4.4	-1.9	0.28	1.8	2.7	2,989	6.2	1,270		45.5	0.28	43.6	3.6	4,236	3.33
	7.2	0.7	0.28	4.3	2.9	3,290	6.3	1,287		45.8	0.28	43.8	3.8	4,556	3.54
	10.0	3.3	0.28	6.8	3.2	3,612	6.4	1,304		46.1	0.28	44.1	4.1	4,894	3.75
	12.8	5.9	0.28	9.3	3.5	3,957	6.4	1,318		46.4	0.28	44.4	4.4	5,254	3.99
	15.6	8.6	0.28	11.7	3.8	4,334	6.5	1,328		46.7	0.28	44.8	4.8	5,641	4.25
	-3.9	-9.7	0.28	-5.7	1.8	2,027	6.5	1,262	46.1	50.5	0.28	49	2.8	3,265	2.59
	-1.1	-6.9	0.28	-3.1	2.0	2,278	6.6	1,295	45.9	50.5	0.28		3.0	3,549	2.74
	1.7	-4.3	0.28	-0.6	2.2	2,537	6.7	1,325	45.7	50.6	0.28		3.2	3,838	2.90
	4.4	-1.6	0.28	1.9	2.5	2,815	6.7	1,350	45.4	50.6	0.28		3.5	4,142	3.07
	7.2	1.1	0.28	4.5	2.8	3,118	6.8	1,372	45.1	50.6	0.28		3.8	4,469	3.26
	10.0	3.8	0.28	7.0	3.0	3,439	6.9	1,392	44.8	50.7	0.28		4.1	4,809	3.46
	12.8	6.4	0.28	9.4	3.4	3,787	6.9	1,408	44.5	50.7	0.28		4.4	5,174	3.67
	15.6	9.2	0.28	11.9	3.7	4,169	7.0	1,424	44.2	50.7	0.28		4.7	5,571	3.91

	ELT (°C)	Cond. Temp.	Flow (L/s)	LLT (°C)	Delta T (°C)	Heat Rej. (W)	Compressor Current (A)	Input Power (W)	EWT (°C)	Evap. Temp.	Flow (L/s)	LWT (°C)	Delta T (°C)	Cooling (W)	COP <sub>C</sub>
	<b>COOLING (METRIC)</b>	15.6	25.1	0.28	20.7	5.1	5,792	4.7	781	12	3.7	0.28	7.8	4.2	5,011
18.3		27.9	0.28	23.4	5.0	5,680	4.8	813	4.0		0.28	7.9	4.1	4,867	5.22
21.1		30.9	0.28	26.0	4.9	5,549	5.0	858	4.3		0.28	8.0	4.0	4,691	4.80
23.9		33.8	0.28	28.7	4.8	5,422	5.2	915	4.6		0.28	8.2	3.8	4,507	4.35
26.7		36.8	0.28	31.4	4.7	5,283	5.4	984	4.9		0.28	8.4	3.6	4,300	3.89
29.4		39.7	0.28	34.0	4.6	5,160	5.7	1,062	5.2		0.28	8.5	3.5	4,098	3.46
32.2		42.6	0.28	36.7	4.5	5,027	6.0	1,151	5.5		0.28	8.7	3.3	3,876	3.04
35.0		45.6	0.28	39.4	4.4	4,908	6.3	1,250	5.8		0.28	8.9	3.1	3,658	2.67



# W-HAC Schematic Diagram

## 208/230-1-60, Rotary Compressor

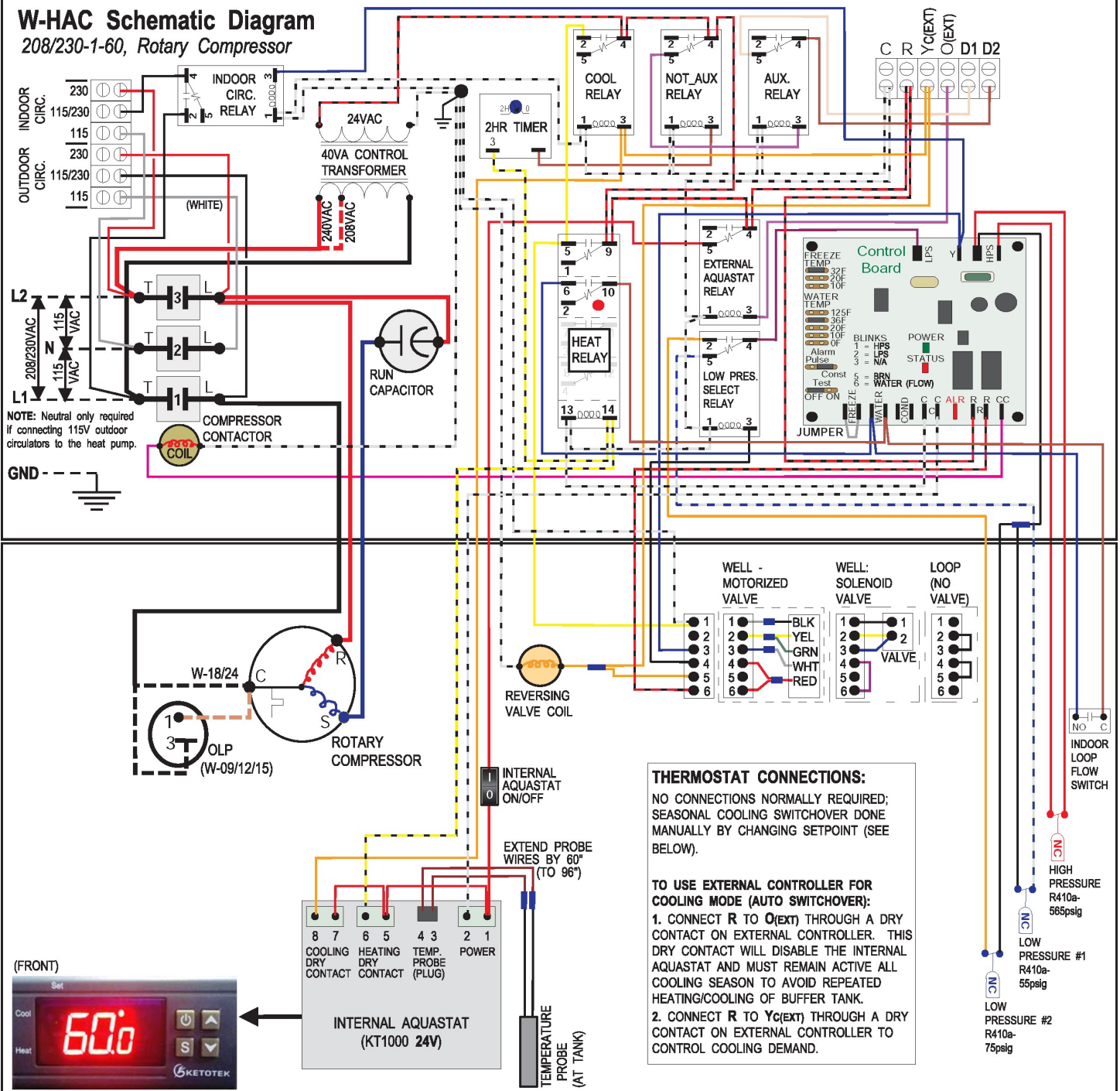

NOTE: Neutral only required if connecting 115V outdoor circulators to the heat pump.

**THERMOSTAT CONNECTIONS:**  
 NO CONNECTIONS NORMALLY REQUIRED; SEASONAL COOLING SWITCHOVER DONE MANUALLY BY CHANGING SETPOINT (SEE BELOW).

**TO USE EXTERNAL CONTROLLER FOR COOLING MODE (AUTO SWITCHOVER):**  
 1. CONNECT R TO O(ext) THROUGH A DRY CONTACT ON EXTERNAL CONTROLLER. THIS DRY CONTACT WILL DISABLE THE INTERNAL AQUASTAT AND MUST REMAIN ACTIVE ALL COOLING SEASON TO AVOID REPEATED HEATING/COOLING OF BUFFER TANK.  
 2. CONNECT R TO Yc(ext) THROUGH A DRY CONTACT ON EXTERNAL CONTROLLER TO CONTROL COOLING DEMAND.

**KT1000 AQUASTAT OPERATION:**

- PRESS THE UP ARROW TO CHECK THE WATER TEMPERATURE SETPOINT.
- PRESS THE DOWN ARROW TO CHECK THE TEMPERATURE DIFFERENTIAL.

HEAT PUMP WILL OPERATE IN HEATING MODE WHEN TANK TEMPERATURE FALLS BELOW SETPOINT BY DIFFERENTIAL, AND WILL OPERATE IN COOLING MODE WHEN TANK TEMPERATURE RISES ABOVE SETPOINT BY DIFFERENTIAL.

WHEN ON/OFF SWITCH IS IN OFF(0) POSITION (OR EXTERNAL COOLING CONTROLLER IS CONNECTED AND ACTIVE), AQUASTAT DISPLAY WILL TURN OFF AND AQUASTAT WILL NOT FUNCTION. SETTINGS WILL BE RETAINED.

**TO CHANGE SETTINGS:**

1. PRESS AND HOLD THE S BUTTON FOR 3 SECONDS.
2. USE ARROW KEYS TO SELECT F1 FOR SETPOINT OR F2 FOR DIFFERENTIAL.
3. PRESS S TO DISPLAY CURRENT VALUE. TO CHANGE, PRESS AND HOLD S WHILE SIMULTANEOUSLY PRESSING AN ARROW KEY. PRESS ⏻ TO SAVE SETTING.

**TO SWITCH FROM HEATING TO COOLING MODE:**  
 USE STEPS 1-3 ABOVE TO CHANGE SETPOINT (F1) FROM HEATING VALUE OF 90-120°F (32-49°C) TO COOLING VALUE OF 45-50°F (7-10°C).

01	000317	D. RHEAULT	D. RHEAULT	4-Aug-2023	Drawn By Dan Rheault	Date 1-Feb-2019	MARITIME GEOTHERMAL LTD. 170 Plantation Rd. Petitcodiac, NB E4Z 6H4	
02	Init.Re-Release	D. RHEAULT	D. RHEAULT	2-May-2022	Checked By Dan Rheault	Date 1-Feb-2019		
00a	Initial Release	D. RHEAULT	D. RHEAULT	26-Mar-2021	Approved By Dan Rheault	Date 1-Feb-2019	Drawing Name W-**-HAC-P-1L-**- Schematic Diagram	
00	Prelim. Rel.	D. RHEAULT	D. RHEAULT	1-Feb-2019	Approved By (MFG)	Date	Size A	
REV	ECO #	IMPL BY	APVD BY	DATE	Approved By	Date	Drawing Number <b>002380SCH</b>	
							Drawing Rev <b>02</b>	SHEET <b>1 of 1</b>

# W-HAC Schematic Diagram

## 265/277-1-60, Rotary Compressor

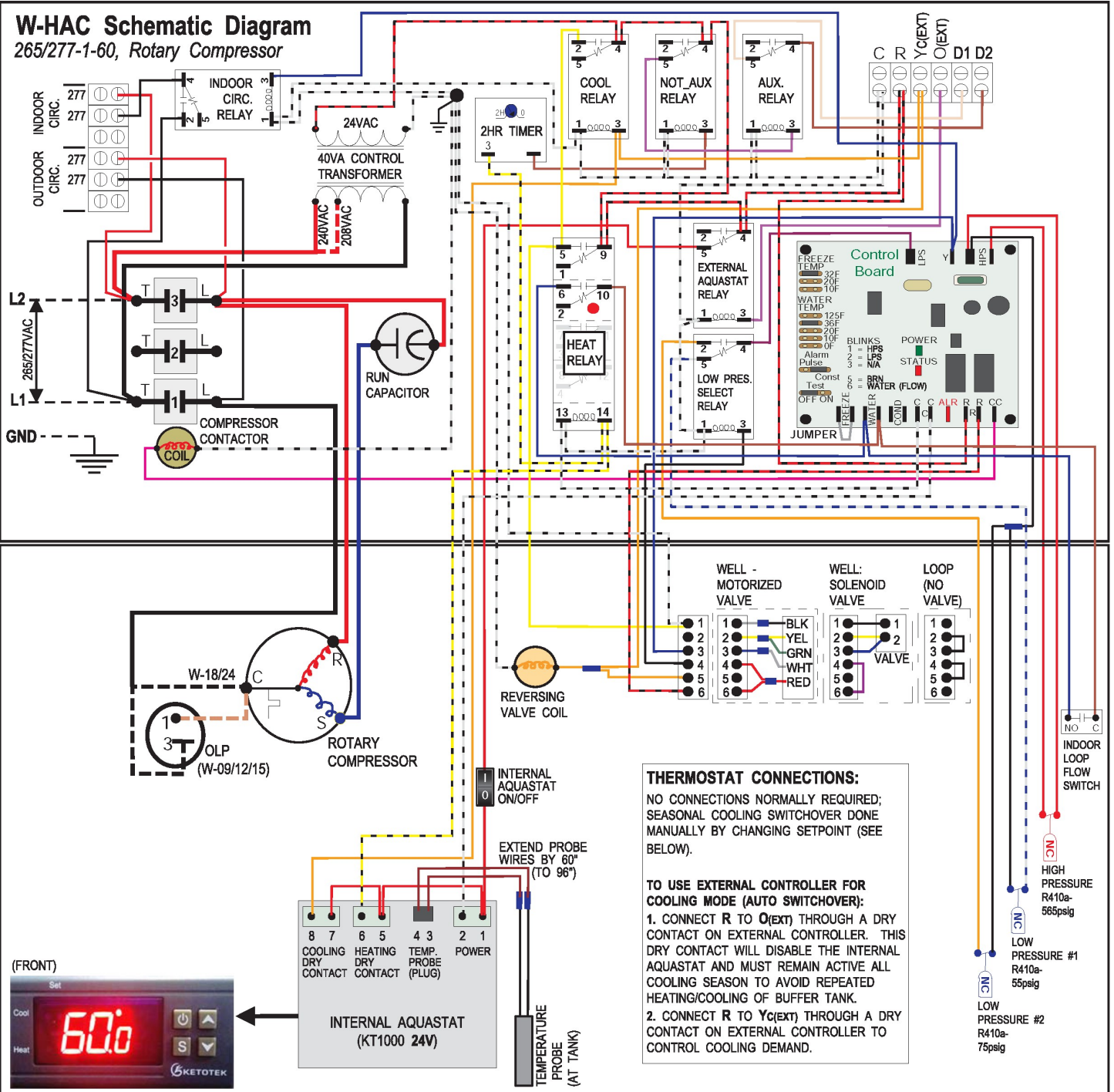

**THERMOSTAT CONNECTIONS:**  
 NO CONNECTIONS NORMALLY REQUIRED; SEASONAL COOLING SWITCHOVER DONE MANUALLY BY CHANGING SETPOINT (SEE BELOW).

**TO USE EXTERNAL CONTROLLER FOR COOLING MODE (AUTO SWITCHOVER):**  
 1. CONNECT R TO O(ext) THROUGH A DRY CONTACT ON EXTERNAL CONTROLLER. THIS DRY CONTACT WILL DISABLE THE INTERNAL AQUASTAT AND MUST REMAIN ACTIVE ALL COOLING SEASON TO AVOID REPEATED HEATING/COOLING OF BUFFER TANK.  
 2. CONNECT R TO Yc(ext) THROUGH A DRY CONTACT ON EXTERNAL CONTROLLER TO CONTROL COOLING DEMAND.

**KT1000 AQUASTAT OPERATION:**  
 - PRESS THE **UP** ARROW TO CHECK THE WATER TEMPERATURE SETPOINT.  
 - PRESS THE **DOWN** ARROW TO CHECK THE TEMPERATURE DIFFERENTIAL.

HEAT PUMP WILL OPERATE IN **HEATING** MODE WHEN TANK TEMPERATURE **FALLS BELOW** SETPOINT BY DIFFERENTIAL, AND WILL OPERATE IN **COOLING** MODE WHEN TANK TEMPERATURE **RISES ABOVE** SETPOINT BY DIFFERENTIAL.

WHEN **ON/OFF** SWITCH IS IN **OFF(0)** POSITION (OR EXTERNAL COOLING CONTROLLER IS CONNECTED AND ACTIVE), AQUASTAT DISPLAY WILL TURN OFF AND AQUASTAT WILL NOT FUNCTION. SETTINGS WILL BE RETAINED.

**TO CHANGE SETTINGS:**  
 1. PRESS AND HOLD THE **S** BUTTON FOR 3 SECONDS.  
 2. USE ARROW KEYS TO SELECT **F1** FOR SETPOINT OR **F2** FOR DIFFERENTIAL.  
 3. PRESS **S** TO DISPLAY CURRENT VALUE. TO CHANGE, PRESS AND HOLD **S** WHILE SIMULTANEOUSLY PRESSING AN ARROW KEY. PRESS **ON** TO SAVE SETTING.

**TO SWITCH FROM HEATING TO COOLING MODE:**  
 USE STEPS 1-3 ABOVE TO CHANGE SETPOINT (F1) FROM HEATING VALUE OF **90-120°F (32-49°C)** TO COOLING VALUE OF **45-50°F (7-10°C)**.

02	000317	D. RHEAULT	D. RHEAULT	4-Aug-2023	Drawn By Dan Rheault	Date 24-Apr-2019	<b>MARITIME GEOTHERMAL LTD.</b> 170 Plantation Rd. Petitcodiac, NB E4Z 6H4
01	Init.Re-Release	D. RHEAULT	D. RHEAULT	2-May-2022	Checked By Dan Rheault	Date 24-Apr-2019	
00a	Initial Release	D. RHEAULT	D. RHEAULT	26-Mar-2021	Approved By Dan Rheault (ENG)	Date 24-Apr-2019	
00	Prelim. Rel.	D. RHEAULT	D. RHEAULT	1-Feb-2019	Approved By (MFG)	Date	
REV	ECO #	IMPL BY	APVD BY	DATE	Approved By	Date	
					Drawing Name W-**-HAC-P-1L-** Schematic Diagram		Size A
					Drawing Number 002383SCH		
							SHEET 1 of 1

# W Series Refrigeration Circuit Heating Mode

ITEM	STATUS
RV#1	DE-ENERGIZED

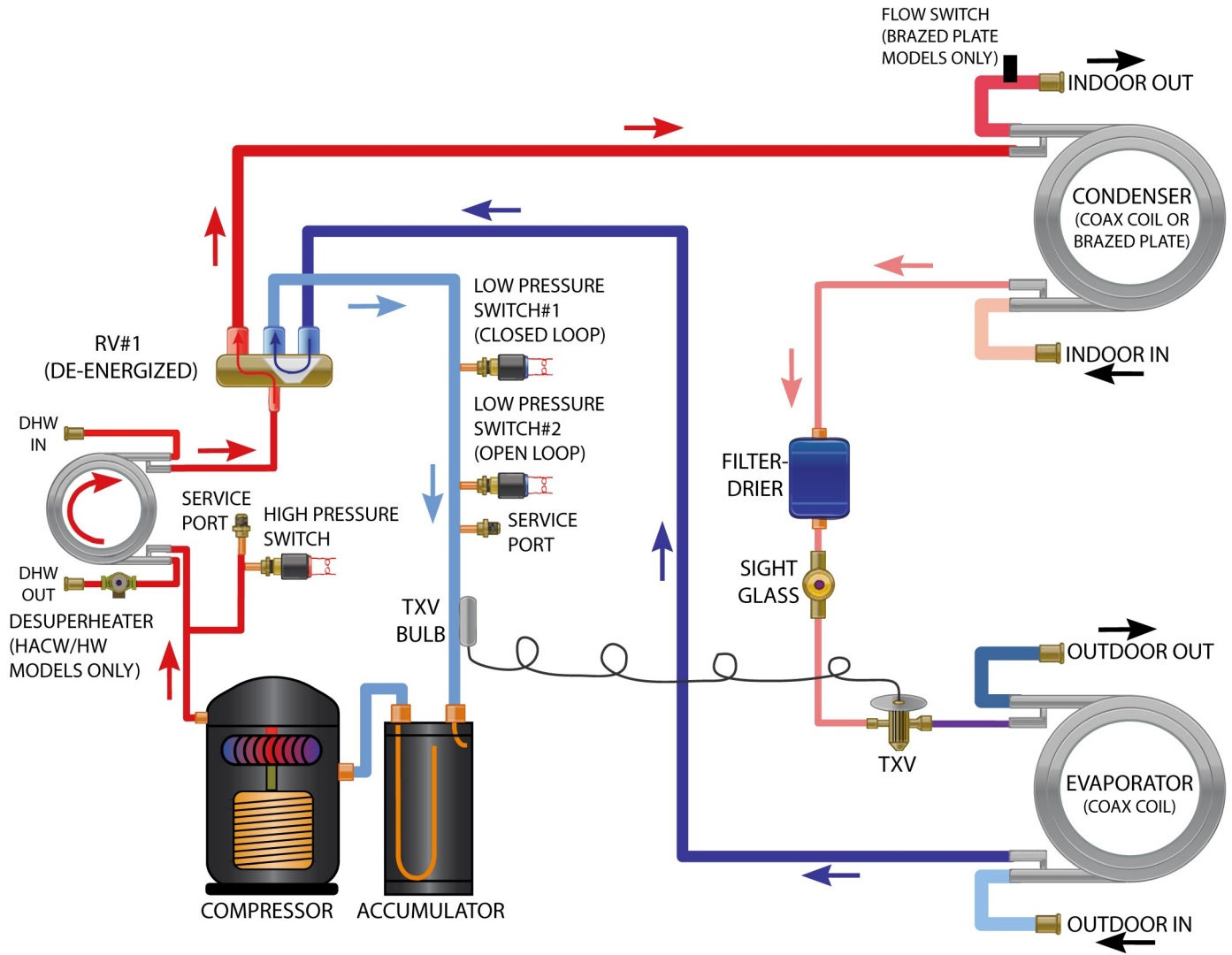

					Drawn By C.GEDDES Date 14 JUN 2011	<b>MARITIME GEOTHERMAL LTD.</b> P.O. Box 2555 170 Plantation Rd. Petitcodiac, NB CANADA E4Z 6H4
					Checked By C.GEDDES Date 14 JUN 2011	
					Eng. Approved By C.GEDDES Date 14 JUN 2011	
					Mfg. Approved By Date	
02	-	D. RHEAULT	D. RHEAULT	25 MAR 2021	Approved By	Date
01	Initial Release	C. GEDDES	C. GEDDES	14 JUN 2011		
REV	ECO#	IMPL BY	APVD BY	DATE		
						Drawing Name <b>W-Series Refrigeration Circuit - Heating Mode</b>
						Size LET
						Drawing Number 001488RCD
						Drawing Revision 02
						Sheet 1 / 1

# W Series Refrigeration Circuit Cooling Mode

ITEM	STATUS
RV#1	ENERGIZED

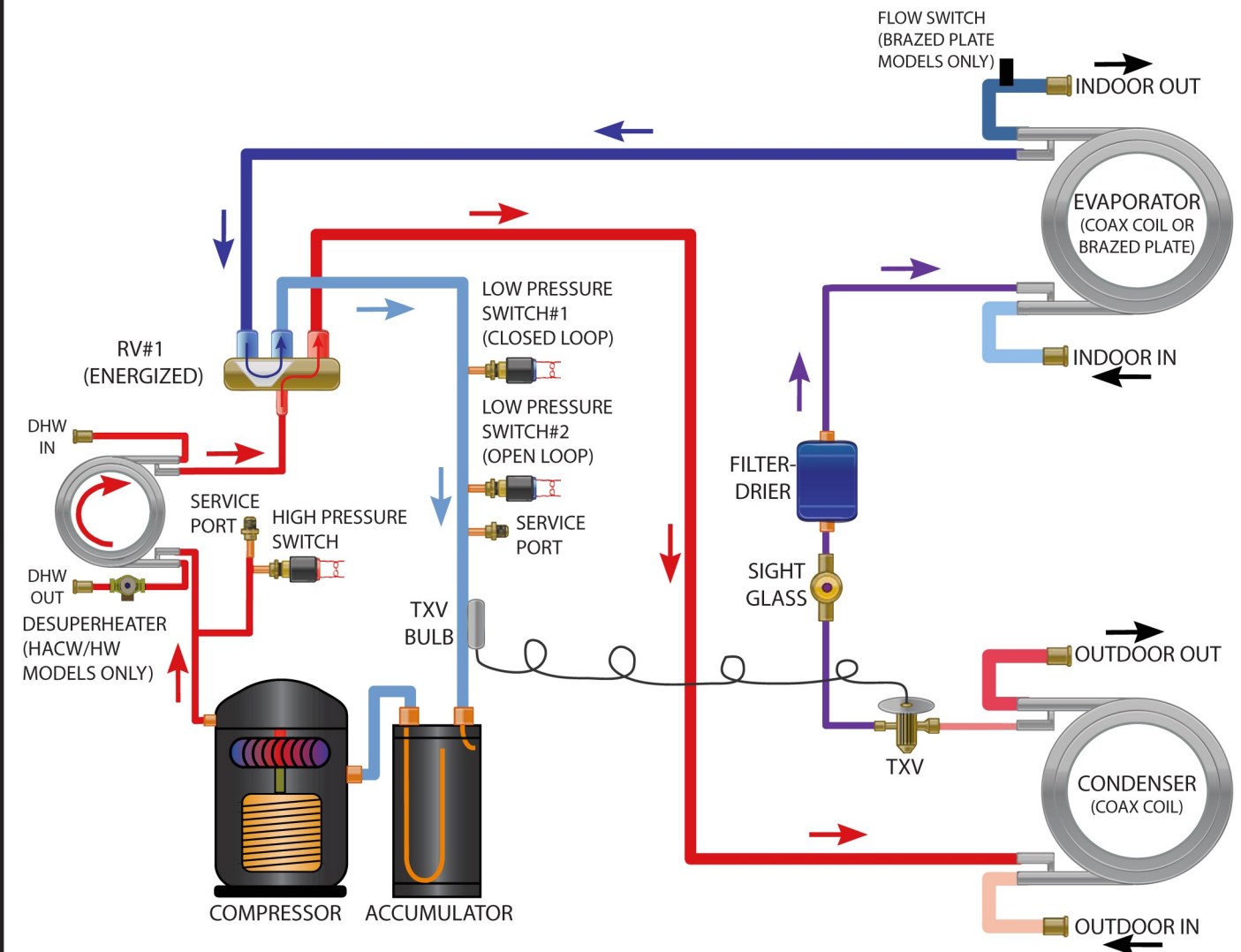

02	-	D. RHEAULT	D. RHEAULT	25 MAR 2021	Drawn By C. GEDDES	Date 14 JUN 2011	<b>MARITIME GEOTHERMAL LTD.</b> P.O. Box 2555 170 Plantation Rd. Petitcodiac, NB CANADA E4Z 6H4	Drawing Name <b>W-Series Refrigeration Circuit - Cooling Mode</b>		
01	Initial Release	C. GEDDES	C. GEDDES	14 JUN 2011	Checked By C. GEDDES	Date 14 JUN 2011				
REV	ECO#	IMPL BY	APVD BY	DATE	Eng. Approved By C. GEDDES	Date 14 JUN 2011				
					Mfg. Approved By	Date				
					Approved By	Date	Size LET	Drawing Number 001489RCD	Drawing Revision 02	Sheet 1 / 1

# Engineering Guide Specifications

---

## General

The liquid source reversing water-to-water heat pump shall be a single packaged reverse-cycle heating/cooling unit. The unit shall be listed by a nationally recognized safety-testing laboratory (NRTL), such as TUV, ETL, UL, or CSA. The unit shall be rated in accordance with applicable standards of the Air Conditioning, Heating, and Refrigeration Institute / International Standards Organization (AHRI/ISO) and/or Canadian Standards Association (CSA). The liquid source water to water heat pump unit, as manufactured by Maritime Geothermal, Petitcodiac, New Brunswick, shall be designed to operate correctly within liquid temperature ranges specified on the "Operating Temperature Limits" table in this engineering specification document.

## Factory Quality

Each unit shall be run tested at the factory with water circulating through the indoor and outdoor loops. Quality control system checks shall include: computerized nitrogen pressurized leak test, evacuation of refrigeration circuit to sustained vacuum, accurate system charge, detailed heating and cooling mode tests, and quality cross check all operational and test conditions to pass/fail criteria. Units tested without water flow are not acceptable. The units shall be warranted by the manufacturer against defects in materials and workmanship in accordance with the warranty section at the end of this document. Optional extended factory warranty coverage may be available.

## Cabinet

Each unit shall be enclosed in a slim wall-hung sheet metal cabinet. Cabinet shall be constructed of powder coated galvanized sheet metal of minimum 20 gauge. Sheet metal gauge shall be higher where structurally required. Design and construction of cabinet shall be such that it is rigid and passes the CSA/UL Loading Test requirements (200 lb roof test and 25 lb guard test). All panels shall be lined with minimum 1/2 inch [12.7 mm] thick acoustic type glass fiber insulation. All insulation shall meet the fire retardant provisions of NFPA 90A. This material shall also provide acoustical benefit. The unit must have a cover that provides adequate serviceability of the compressor compartment. The electrical box shall have separate holes and knockouts for entrance of line voltage and low voltage control wiring. All factory-installed wiring passing through factory knockouts and openings shall be protected from sheet metal edges at openings by plastic grommets.

## Refrigerant Circuit

All units shall contain only one sealed refrigerant circuit, containing a hermetic motor rotary compressor with suction accumulator, a coaxial heat exchanger for the outdoor loop, brazed plate heat exchanger for the indoor loop, thermostatic expansion valve (TXV), reversing valve, factory installed high and low pressure safety switches, service ports, liquid line filter-dryer, and sight glass.

Compressors shall be specified for heat pump duty with internal isolation consisting of rubber vibration isolators between the compressor and mounting plate, and rubber vibration isolators between the mounting plate and cabinet. Compressor motors shall have overload protection.

The coaxial water to refrigerant heat exchanger shall consist of a steel outer jacket with twisted copper inner tube, designed and certified for 600 psig [4136 kPa] working pressure on the refrigerant side and 500 psig [3108 kPa] on the water side. Heat exchangers shall be insulated over all of their outside surface with minimum 3/8" thick closed cell insulation. Insulation consisting of 1/8" closed-cell insulating tape shall not be acceptable. Cupro-nickel (CuNi) inner tube shall be available as a factory option.

The brazed plate water to refrigerant heat exchanger shall be constructed from stainless steel, designed and certified for 600 psig [4136 kPa] working pressure on the refrigerant side and 500 psig [3108 kPa] on the water side. Heat exchangers shall be insulated over all of their outside surface with minimum 3/8" thick closed cell insulation. Insulation consisting of 1/8" closed-cell insulating tape shall not be acceptable. The brazed plate shall be protected with a factory installed flow switch.

The thermostatic expansion valve shall be a balanced port bi-flow type with internal bleed and shall provide proper superheat control over the unit's operating range with minimal deviation from the superheat setpoint.

## **Piping and Connections**

The unit shall have two sets of primary water in and out connections (for indoor and outdoor loops). The primary connection type shall be 3/4" nominal female National Pipe Thread (NPT). All water connectors shall be rigidly mounted to cabinet with corrosion resistant fasteners to prevent relative movement. All water connectors shall be constructed of copper or brass material for corrosion resistance.

All internal water and refrigerant piping shall be insulated with minimum 3/8" thick closed cell insulation. Insulation consisting of 1/8" closed-cell insulating tape shall not be acceptable.

## **Electrical**

Controls and safety devices shall be factory wired and mounted within the unit. Controls shall include a 24 volt alternating current (24VAC) 40VA class II control transformer with resettable breaker or fuses for short circuit protection, to provide power to all internal controls as well as a remote thermostat. Terminal strips with screw terminals shall be provided for field control wiring, power supply line connections and 115/230VAC power supply for outdoor loop (ground loop) circulators. Units shall be name-plated for use with time delay fuses or circuit breakers.

## **Unit Control**

The control system shall have the following features:

1. Built-in aquastat for heating and cooling modes, with connection for optional external aquastat for automatic cooling switchover applications.
2. Anti-short cycle time delay on compressor operation. Time delay shall be a minimum of 5 minutes, for both thermostat demand and safety control reset starts. A test jumper shall be provided to disable this delay for unit commissioning and testing purposes. The unit shall revert to normal operation after a time delay if the test jumper is accidentally left in place.
3. Random compressor start delay of 0-120 seconds (in addition to 5 minute anti-short cycle timer) on unit power up to facilitate starting multiple units on one disconnect switch or after a power failure.
4. Compressor shutdown for high or low refrigerant pressures.
5. Low grid voltage or 'brownout' protection, which will prevent compressor operation if low voltage is detected.
6. Automatic intelligent reset: unit shall automatically restart 5 minutes after a trip if the fault has cleared. Should a fault reoccur again within 60 minutes then a permanent lockout shall occur, requiring cycling of the power to the unit in order to reset.

Maritime Geothermal works continually to improve its products. As a result, the design and specifications of any product may be changed without notice. Please contact Maritime Geothermal at 1-506-756-8135 or visit [www.nordicghp.com](http://www.nordicghp.com) for latest design and specifications. Purchaser's approval of this data set signifies that the equipment is acceptable under the provisions of the job specification. Statements and other information contained herein are not express warranties and do not form the basis of any commercial contract or other agreement between any parties, but are merely Maritime Geothermal's statement of opinion regarding its products.

# LIMITED RESIDENTIAL WARRANTY

MARITIME GEOTHERMAL LTD. warrants that the heat pumps manufactured by it shall be free from defects in materials and workmanship for a period of (5) FIVE YEARS after the date of installation or for a period of (5) FIVE YEARS AND (60) SIXTY DAYS after the date of shipment, whichever occurs first. In addition MARITIME GEOTHERMAL LTD. warrants that the compressor shall be free of defects in materials and workmanship for an additional period of (2) TWO YEARS from said date.

MARITIME GEOTHERMAL LTD. shall, at its option repair or replace any part or parts covered by this warranty which shall be returned to MARITIME GEOTHERMAL LTD., transportation charges prepaid, which, upon examination proves to be defective in materials or workmanship. Replacement or repaired parts and components are warranted only for the remaining portion of the original warranty period.

This warranty is subject to the following conditions:

1. The NORDIC® heat pump must be properly installed and maintained in accordance with MARITIME GEOTHERMAL LTD.'s installation and maintenance instructions.
2. The installer must complete the “**Installation Data Sheet**”, have it endorsed by the owner and return it to Maritime Geothermal Ltd. within 21 days of installation of the unit.
3. It is the responsibility of the building or general contractor to supply temporary heat to the structure prior to occupancy. These heat pumps are designed to provide heat only to the completely finished and insulated structure. Start-up of the unit shall not be scheduled prior to completion of construction and final duct installation for validation of this warranty.
4. It is the customer's responsibility to supply the proper quantity and quality of water.

If the heat pump, manufactured by MARITIME GEOTHERMAL LTD., fails to conform to this warranty, MARITIME GEOTHERMAL LTD.'s sole and exclusive liability shall be, at its option, to repair or replace any part or component which is returned by the customer during the applicable warranty period set forth above, provided that (1) MARITIME GEOTHERMAL LTD. is promptly notified in writing upon discovery by the customer that such part or component fails to conform to this warranty. (2) The customer returns such part or component to MARITIME GEOTHERMAL LTD., transportation charges prepaid, within (30) thirty days of failure, and (3) MARITIME GEOTHERMAL LTD.'s examination of such component shall disclose to its satisfaction that such part or component fails to meet this warranty and the alleged defects were not caused by accident, misuse, neglect, alteration, improper installation, repair or improper testing.