

# Engineering Specification

## PC-75-P-*S*-T/X-KDER\* Pool Conditioner

### Pool Room Dehumidifier

with Heat Recovery to Air (standard)

with Heat Recovery to Pool Water (option)

with Heat Rejection to Outdoor Unit or Ground Loop (option)



*optional outdoor unit  
for air conditioning*

Maritime Geothermal Ltd.  
P.O. Box 2555, 170 Plantation Road  
Petitcodiac, NB E4Z 6H4  
(506) 756-8135



info@nordicghp.com  
www.nordicghp.com  
002302SPC-04

# Model Nomenclature

PC-75-P-1S-T-KDERS-xx

**Series:**  
PC = Pool Conditioner

**Nominal Size:**  
45 = 031 compressor  
55 = 042 compressor  
65 = 054 compressor  
75 = 061 compressor  
80 = 072 compressor

**Refrigerant:**  
P = R410a

**Voltage Code:**  
1 = 208/230-1-60  
2 = 208-3-60  
4 = 460-3-60  
6 = 220-1-50  
7 = 380-3-50

**Compressor:**  
S = single stage scroll

**Revision:**  
01, 02 etc.

**Air Discharge:**  
S = Side (end)  
T = Top (up)  
D = Down

**Air Return:**  
R = Right Side

**Blower Motor:**  
E = ECM (Variable Speed)

**Blower Type:**  
D = Direct Drive

**Air Coil:**  
K = Coated

**Indoor Loop (Pool) Exchanger:**  
T = Titanium  
X = NONE

AC2-75-P-1/6-KDE-xx

**Series:**  
AC2 = PC Outdoor Condenser

**Nominal Size:**  
45 = for PC-45  
55 = for PC-55  
65 = for PC-65  
75 = for PC-75  
80 = for PC-80

**Revision:**  
01, 02 etc.

**Blower Motor:**  
E = ECM (Variable Speed)

**Blower Type:**  
D = Direct Drive

**Air Coil:**  
S = Standard  
K = Coated

**Voltage Code:**  
1/6 = 208-277VAC, 50/60Hz

APPLICATION TABLE - PC-SERIES INDOOR UNIT										
MODEL	REFRIGERANT	VOLTAGE	STAGES	INDOOR COIL	COILS/BLOWER/ AIR RETURN	AIR DISCHARGE	REVISIONS			
PC-75	P	1 2 4 6 7	S	T	K D E R	T S D	12			
				X	K D E R	T S D	01			

This manual applies only to the models and revisions listed in this table.

APPLICATION TABLE - OPTIONAL AC2-SERIES OUTDOOR UNIT										
MODEL	REFRIGERANT	VOLTAGE	AIR COIL	BLOWER TYPE	BLOWER MOTOR	REVISIONS				
AC2-65/75/80	P	1/6	K	D	E	02				

This manual applies only to the models and revisions listed in this table.

APPLICATION TABLE - OPTIONAL GROUND LOOP HEAT EXCHANGER / WATER COIL			
PC MODEL SIZE	ACCESSORY WATER COIL		CIRCULATOR
PC-75	03-7040	(BTSSC-84)	UP26-99/NRF-36 OR EQUIV.

APPLICATION TABLE - FIRMWARE AND PC APP			
Firmware	Version*	Associated PC APP	Version
MGT GEN2 Bootload Firmware	V3.85+	MGT GEN2 PC APP	V2.07+

Maritime Geothermal Ltd. has a continuous improvement policy and reserves the right to modify specification data at any time without prior notice .

# Design Features

---

- Pool room dehumidifier, an energy efficient alternative to ventilating air for pool room humidity control
- Available with or without pool water coil for heat rejection to pool water
- Rejects its heat to pool water (if equipped, providing all the heat for pool), pool room air, or optional outdoor unit / existing geothermal ground loop
- TUV certified for safety (CSA 22.2), CE certified
- Satin galvanized steel cabinet with powder coat finish, for corrosion resistance superior to stainless steel
- Acoustically insulated cabinet
- All connections located on front side
- Four access panels, requiring service access to front side only
- Component layout allows easy access for service
- Refrigeration service ports accessible from outside unit (1/4" Schrader)
- Titanium/PVC coaxial pool water heat exchanger, corrosion resistance superior to copper or CuNi
- 2" PVC unions for pool water connections, for quick and easy disconnect
- Galvanized, full sized (not 'tight') blower with premium ECM for constant airflow regardless of external static pressure
- TOP, SIDE, or DOWN air discharge from factory
- Dry contacts for air auxiliary heat, with included electric plenum heater 15 or 20 kW (externally mounted)
- Dry contact to control pool pump, if required (if equipped with pool water coil)
- Dry contacts to control pool auxiliary heat (if equipped with pool water coil)
- Onboard pool water temperature control means no external sensor or aquastat required
- Scroll compressor with start capacitor kit on single phase models
- Dual-grommet-mounted compressor for reduced noise and vibration
- Suction line accumulator & refrigerant receiver
- Liquid line filter-dryer, sight glass
- Electronic Expansion Valve (EEV) for precise superheat control and maximum capacity
- 4-way (reversing) valves for refrigerant routing
- Refrigerant pressure/temperature & pool water temperature sensor with real-time readout
- Advanced control board with BACnet interface for remote operation and data access including all sensor data and alarm conditions, PWM outputs (or 0-10VDC), configurable analog inputs (0-5VDC or 4-20mA) with onboard 5VDC, 12VDC and 24VDC power supplies
- USB port for complete data access via free PC software including real-time charting, data logging, and diagnostic functionality with manual override operation
- 2 x 16 LCD display for control and data access
- Communicating air thermostat with temperature & humidity, with wire, included

# Available Accessories

---

- AC2-Series outdoor condenser, to enable air cooling when pool is already heated to desired setpoint
- Externally mounted flow switch, for applications where PC unit does not have control of pool pump
- Ground loop heat exchanger to reject heat to an existing geothermal ground loop, an alternative to using the AC2-Series outdoor unit
- Anti-vibration pad for under unit
- Compressor sound jacket
- Compressor Secure Start module
- Reusable, passive electrostatic air filter

# Design Features

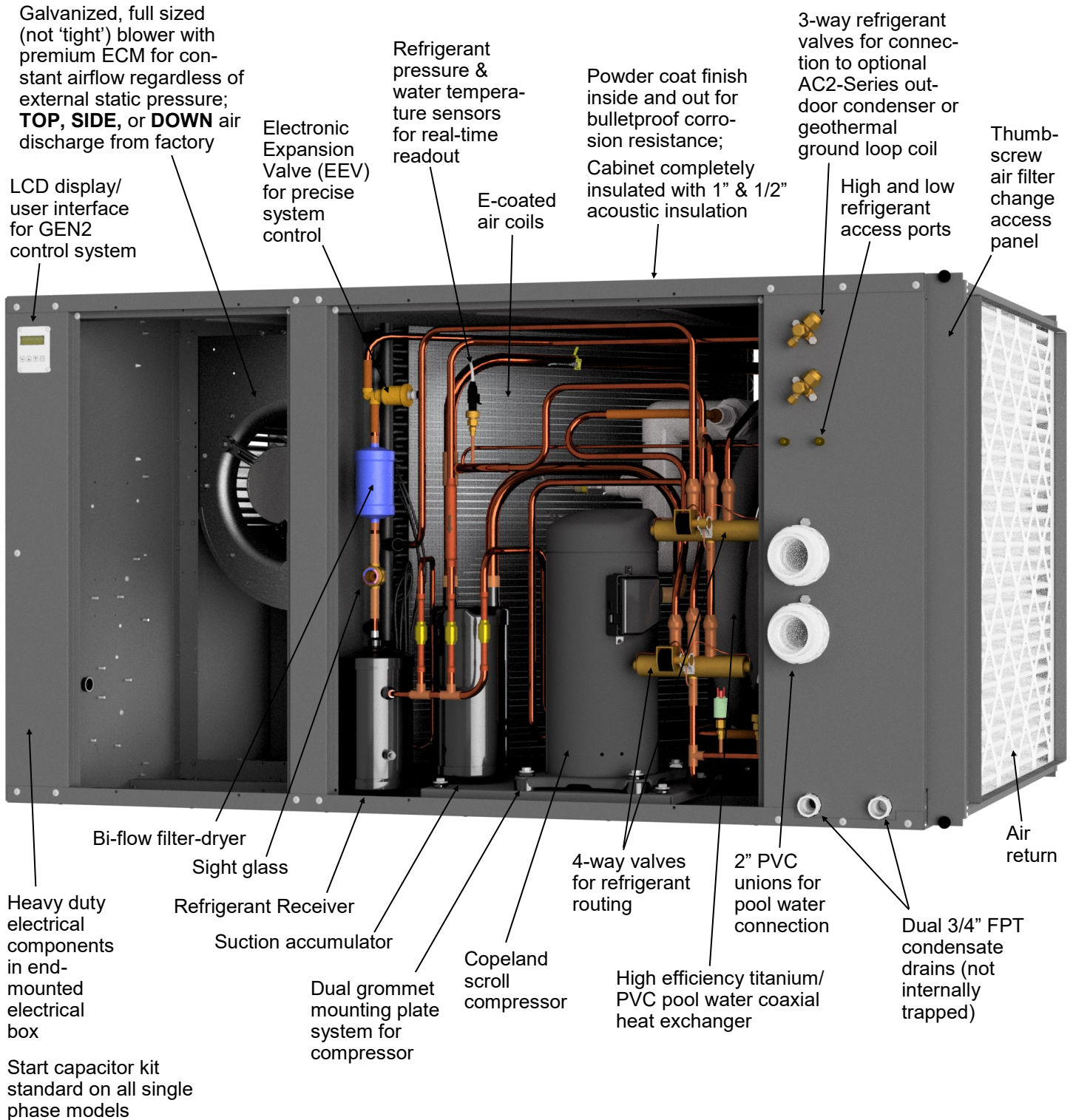

TUV certified for electrical safety to CSA 22.2.



CE certified

# Dimensions

All dimensions in inches

## Dimensions: PC-75

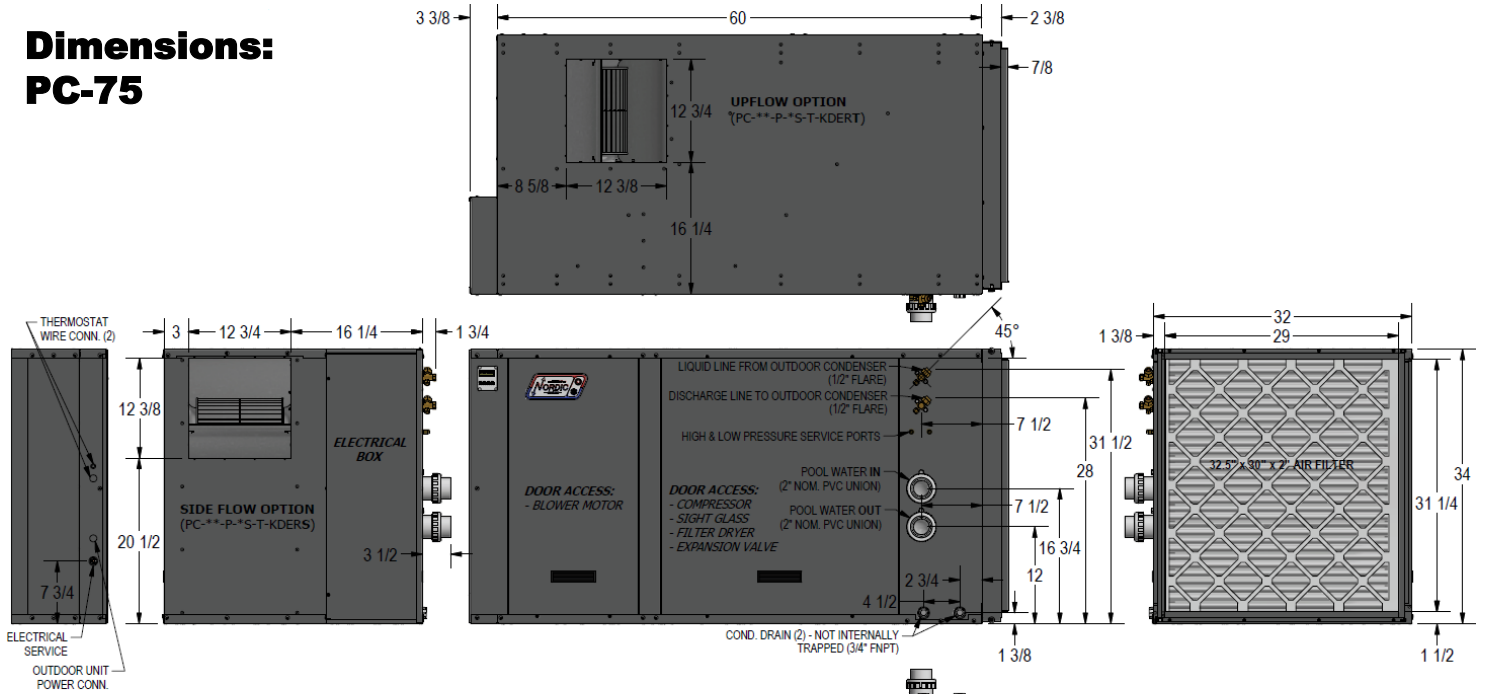

### RECOMMENDED CLEARANCES

FRONT **2 FT**

LEFT SIDE **2 FT**

## Dimensions: AC2-75

### RECOMMENDED CLEARANCES

FRONT **10-16 FT**

BACK SIDE **12"**

LEFT SIDE **2 FT**

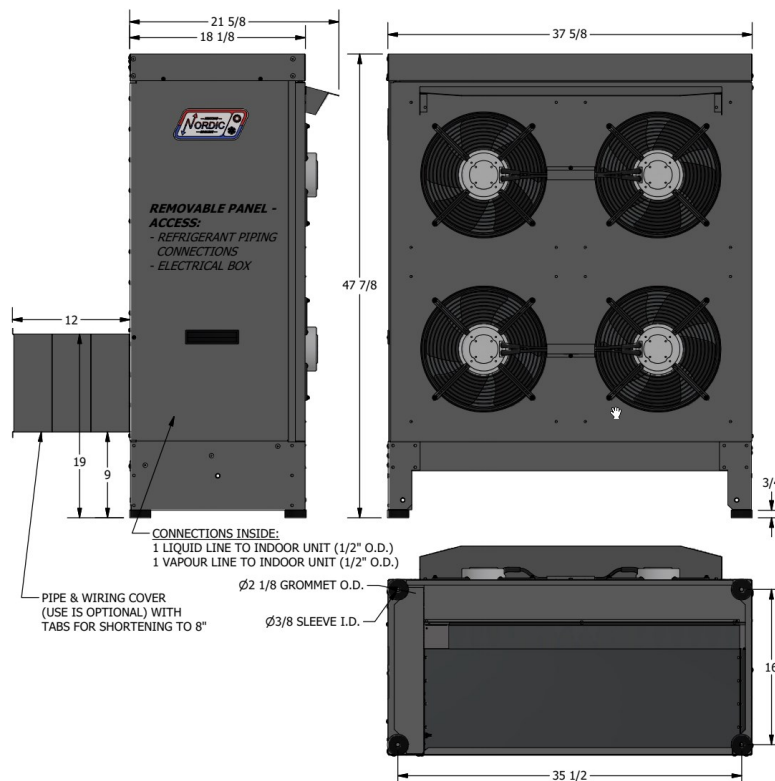

# Specifications

Shipping Information (PC)				
MODEL	WEIGHT lb. (kg)	DIMENSIONS in (cm)		
		L	W	H
PC-75	610 (277)	70 (178)	44 (112)	40 (102)

Shipping Information (AC2 Outdoor Unit)				
MODEL	WEIGHT lb. (kg)	DIMENSIONS in (cm)		
		L	W	H
AC2-75	295 (134)	36 (91)	70 (178)	56 (142)

Refrigerant Charge				
MODEL	lb	kg	Refrigerant	Oil Type
PC-75	12.0	5.4	R410a	POE

Control Temperature Limits			
Parameter	Device	MIN.	MAX.
Room Relative Humidity (RH)	Room Thermostat or BACnet	30%	80%
Room Air Temperature	Room Thermostat or BACnet	50°F (10°C)	95°F (35°C)
Pool Water Temperature	Internal Setpoint Control or optional aquastat or BACnet	70°F (21°C)	108°F (42°C)

AC2-Series Outdoor Unit Sound Levels (dBA)*								
MODEL	1 ft distance		3 ft distance		5 ft distance		10 ft distance	
	Front	Side	Front	Sides	Front	Sides	Front	Sides
AC2-75	71.7	66.8	68.7	63.7	65.7	61.2	60.0	57.1

\* At maximum fan speed. This occurs in heating mode, or in cooling mode with outdoor greater than ~27°C.

PC-Series Electrical Data										
MODEL	Nomenclature Identifier	Power Supply			Compressor		FLA	MCA	Maximum Fuse/Breaker	Minimum Wire Size
		V- $\phi$ -Hz	MIN	MAX	RLA	LRA	Amps	Amps	Amps	ga
PC-75	1	230-1-60	187	253	30.8	178	37.5	45.2	60	#6-2
	2	208-3-60	187	229	19.6	136	26.3	31.2	50	#8-3
	4	460-3-60	414	506	8.2	66	14.9	17.0	30	#10-3
	7	380-3-50	342	418	8.0	67	14.7	16.7	30	#10-3

Plenum Heater Electrical Data															
Size (kW)	(230-1-60)					(208-1-60)					(220-1-50)				
	Actual (kW)	FLA (A)	MCA (A)	Breaker (A)	Wire Size	Actual (kW)	FLA (A)	MCA (A)	Breaker (A)	Wire Size	Actual (kW)	FLA (A)	MCA (A)	Breaker (A)	Wire Size
5	5	20.8	26.0	30	#10	3.8	18.1	22.6	30	#10	4.2	19.1	19.1	30	#10
7	7	29.2	36.5	40	#8	5.3	25.3	31.6	40	#8	5.9	26.7	26.7	40	#6
10	10	41.7	52.1	60	#6	7.5	36.1	45.1	50	#6	8.4	38.1	38.1	50	#6
15	15	62.5	78.1	80	#4	11.3	54.2	67.7	80	#4	12.6	57.2	57.2	80	#3
20	20	83.3	104.2	100	#3	15.0	72.2	90.3	100	#3	16.8	76.3	76.3	100	#3

Required Water Flow Rates						
MODEL	POOL WATER FLOW		OPTIONAL GROUND LOOP HEAT REJECTION WATER COIL			
	gpm	L/s	MGL P/N	COIL	gpm	L/s
PC-75	40	2.5	03-7040	BTSSC-84	16	1.0

Pool Water Pressure Drop (all PC model sizes)		
Flow (gpm)	psi	kPa
20	1.5	10
25	2.2	15
30	2.9	20
35	3.8	26
40	4.7	32
45	5.8	40
50	6.9	48
60	9.5	66

PC-75 →

Pressure Drop for  
Optional Ground Loop  
Heat Rejection Coil

			Water 104°F		Water 50°F		15% Methanol 32°F		35% prop. glycol 32°F	
	gpm	L/s	psi	kPa	psi	kPa	psi	kPa	psi	kPa
PC-75 (coil 03-7040)	11	0.69	2.9	20	3.2	22	4	28	5.3	36
	12	0.76	3.6	25	3.9	27	4.6	32	6.0	42
	13	0.82	4.1	28	4.4	30	5.2	36	6.8	47
	14	0.88	4.7	32	5	34	5.8	40	7.6	53
	15	0.95	5.5	38	5.7	39	6.5	45	8.5	59
	16	1.01	6.3	43	6.5	45	7.3	50	9.6	66
	17	1.07	7.1	49	7.3	50	8.1	56	10.7	74



### PC-Series Capacity Ratings

MODEL	Power Supply (Hz)	Indoor (Pool) Flow		Indoor (Pool) Pressure Drop	Airflow	Input Energy	Capacity	Moisture Removal @ 50%RH	Moisture Removal @ 60%RH	Typical Pool Surface Area
		gpm	L/s	psi (kPa)	cfm (L/s)	Watts	Btu/hr (kW)	lb(kg) / hr	lb(kg) / hr	ft <sup>2</sup> (m <sup>2</sup> )
PC-75	60	40	2.5	4.3 (30)	2200 (1040)	4570	87,000 (25.5)	28 (13)	33 (15)	1200 (110)
	50	40	2.5	4.3 (30)	2200 (1040)	3900	73,000 (21.4)	23 (11)	28 (13)	1,000 (93)

\*EWT (Tp)=80°F (26.7°C) and EAT (Ta)=82°F (27.8°C)

### Indoor Airflow

Mode	Nominal		Range		Airflow Reduction - 20%		Airflow Reduction - 15%		Airflow Reduction - 10%		Airflow Reduction - 5%	
	cfm	L/s	cfm	L/s	cfm	L/s	cfm	L/s	cfm	L/s	cfm	L/s
NORMAL	2200	1040	1750-2500	830-1180	1760	830	1870	880	1980	940	2090	990
AUX. HEAT	2200	1040	2000-2500	940-1180	1760	830	1870	880	1980	940	2090	990
RECIRC.	1250	590	1000-1500	470-710	1000	470	1060	500	1130	530	1190	560

## Cooling Mode Performance Tables (Heat Rejection to AC2 Outdoor Unit)

PC-75 with AC2-75 R410a, 60 Hz

	OUTDOOR LOOP (Air)			ELECTRICAL			INDOOR LOOP (Air @ 50% RH)								
	Outdoor Air Temperature	Condensing Temperature	Heat Rejected (Btu/hr)	Compressor Current (A)	Fan (W)	Input Power (W)	EAT	Evap. Temp.	Airflow (cfm)	LAT (°F)	Delta T (°F)	Latent (Btu/hr)	Sensible (Btu/hr)	Cooling (Btu/hr)	EER
COOLING	50°F	63	88,261	14.0	450	3,311	80°F	46	2,200	55	25	23,167	53,291	76,458	23.1
	60°F	73	85,697	15.5	450	3,593		46	2,200	56	24	22,098	50,834	72,932	20.3
	70°F	83	83,316	17.0	450	3,984		46	2,200	57	23	20,973	48,244	69,217	17.4
	80°F	93	80,444	18.7	450	4,290		47	2,200	58	22	19,786	45,514	65,300	15.2
	90°F	104	77,778	20.8	450	4,733		47	2,200	60	20	18,261	42,813	61,074	12.9
	100°F	114	74,910	23.0	450	5,194		47	2,200	61	19	16,933	39,699	56,632	10.9
	110°F	124	72,324	25.6	450	5,801		47	2,200	63	17	15,541	36,435	51,976	9.0
	120°F	134	69,726	28.6	450	6,447		47	2,200	64	16	14,105	33,068	47,173	7.3

METRIC

	OUTDOOR LOOP (Air)			ELECTRICAL			INDOOR LOOP (Air @ 50% RH)								
	Outdoor Air Temperature	Condensing Temperature	Heat Rejected (W)	Compressor Current (A)	Fan (W)	Input Power (W)	EAT	Evap. Temp.	Airflow (L/s)	LAT (°C)	Delta T (°C)	Latent (W)	Sensible (W)	Cooling (W)	COP <sub>c</sub>
COOLING	10°C	17.2	25,860	14.0	450	3,311	27°C	7.8	1,040	12.6	14.1	6,788	15,614	22,402	6.77
	16°C	22.8	25,109	15.5	450	3,593		7.9	1,040	13.2	13.4	6,475	14,894	21,369	5.95
	21°C	28.3	24,411	17.0	450	3,984		8.0	1,040	13.9	12.8	6,145	14,135	20,280	5.09
	27°C	33.9	23,570	18.7	450	4,290		8.1	1,040	14.6	12.0	5,797	13,336	19,133	4.46
	32°C	40.0	22,789	20.8	450	4,733		8.2	1,040	15.3	11.3	5,350	12,544	17,895	3.78
	38°C	45.6	21,948	23.0	450	5,194		8.3	1,040	16.2	10.5	4,961	11,632	16,593	3.19
	43°C	51.1	21,191	25.6	450	5,801		8.4	1,040	17.0	9.6	4,553	10,675	15,229	2.63
	49°C	56.7	20,430	28.6	450	6,447		8.6	1,040	17.9	8.7	4,133	9,689	13,822	2.14

# BACnet Interface

The BACnet interface is an **MS/TP** connection via RS-485 twisted pair. BACnet **IP** is not available. Recommended wire: 22-24 AWG single twisted pair, 100-120 Ohms impedance, 17pF/ft or lower capacitance, with braided or aluminum foil shield, such as Belden 9841 or 89841.

The connector on the control board is a three wire removable screw connector. The signals are as follows:

- A: Communications line (+) (right pin)
- B: Communications line (-) (middle pin)
- C: Ground connection (left pin)

If connecting multiple units to one RS-485 connection point, connect the signal cable from the master building controller to the first unit. Connect the second unit to the first unit (in same connector), connect the third unit to the second unit, and so on until all units are connected (daisy-chain). Remove the TERM jumper (located just above the BACnet connector on control board) from all units except the last one. The shield ground should be connected only to the GND pin of the unit for single unit installations. For multiple units, the shield ground should only be connected to the GND pin of the last unit. The shield grounds for intermediate units should be connected together. The shield ground should be left unconnected at the building controller end for all cases.

Vendor: Maritime Geothermal Ltd.  
Vendor ID: 260  
Model Name: MGT GEN2 Control Board

The following parameters can be set via the PC App's *Configuration Window*:

- 1) **Baud rate**  
9600, 19200, 38400, or 76800
- 2) **MAC address**  
Maximum value is 125.
- 3) **Instance number**  
Maximum value is 4194303.

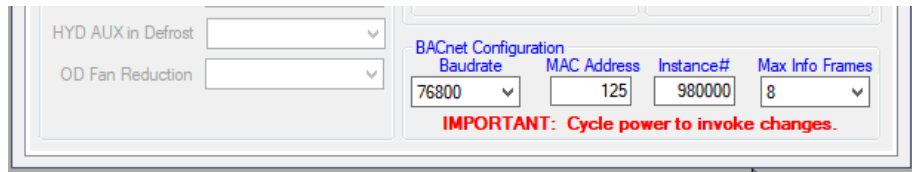

The BACnet parameter **Max\_Master** has a fixed value of **127** in this device.

BACnet data is available regardless of the selected control method. In order to control the unit via the BACnet interface, set **Control Source** to **BACnet** either by using the PC App's configuration window or the LCD menus.

**Refer to *Application, Installation, & Service Manual* for BACnet objects (read and write).**

# PC-Series (GEN2) Schematic Diagram 208/230-1-60

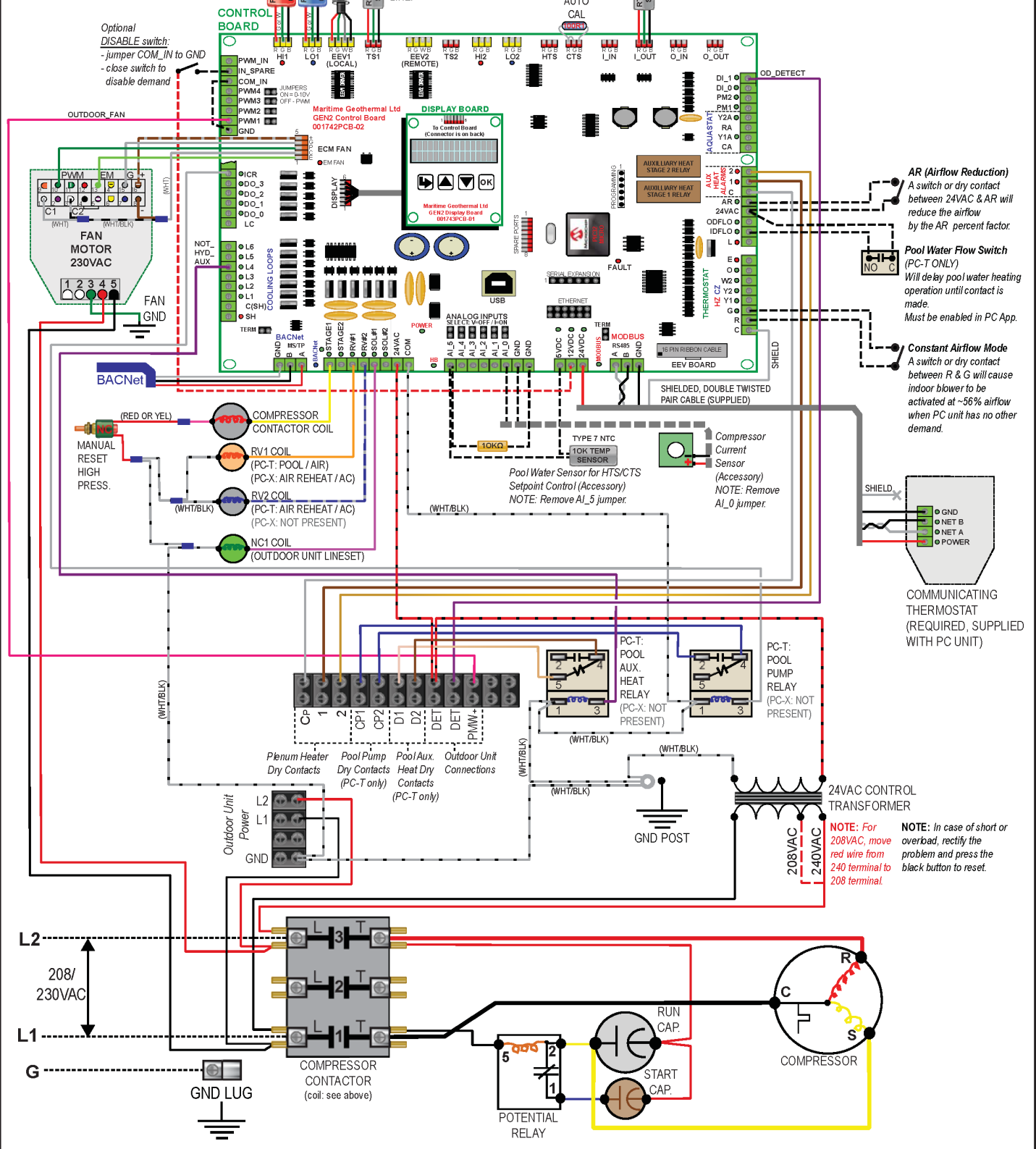

04	000321	D. RHEAULT	D. RHEAULT	1-May-2024	Drawn By C. GEDDES	Date 20-Oct-2011	<p>P.O. Box 2555 170 Plantation Rd. Pettitcodiac, NB CANADA E4Z 6H4</p>	
03	ISSUE 05	D. RHEAULT	D. RHEAULT	11-Apr-2024	Checked By C. GEDDES	Date 20-Oct-2011		
03	ISSUE 04	D. RHEAULT	D. RHEAULT	21-Sep-2023	Eng. Approved By C. GEDDES	Date 20-Oct-2011		
03	ISSUE 03	D. RHEAULT	D. RHEAULT	17-May-2023	Mfg. Approved By	Date		
03	ISSUE 02	D. RHEAULT	D. RHEAULT	27-Sep-2021	Approved By	Date		
REV	ECO#	IMPL BY	APVD BY	DATE			Drawing Name <b>PC-**-*-1S-T/X-KDER*</b> Schematic Diagram	
					Size LET	Drawing Number 001423SCH	Drawing Rev 04	Sheet 1 / 1

**PC-Series (GEN2)**  
**Electrical Box Diagram**  
**208/230-1-60**

**ROOM THERMOSTAT (REQUIRED)**

Connect the communicating thermostat directly to board with supplied shielded, double twisted pair cable:

- A - communication: use **one twisted pair**
- B - power: use **other twisted pair**

**CONSTANT AIRFLOW MODE**

A switch or dry contact between R & G will activate the indoor blower at ~56% airflow when no other demand.  
 R - 24VAC  
 G - blower activation

**BACNet CONNECTIONS (MS/TP RS-485)**

Use a shielded, twisted pair cable to connect the optional BACNet connections to the control board.

- A - communication: use **one twisted pair**
- B - Ground

BACNet Object	Activation
SYSTEM_G	Constant Airflow/Fan Recirculation Mode
SYSTEM_Y1	Air Reheat/Aux.Heat or Air Cool Demand
SYSTEM_O	Air Heating (OFF) / Air Cooling (ON)
SYSTEM_Y1A	Pool Water Heat Demand
SYSTEM_DH	Air Dehumidify Demand

**PLENUM HEATER DRY CONTACTS**

Use an 18-3 cable to connect the air plenum heater control board to the pool conditioner terminal strip:  
 CP - 24VAC from plenum heater  
 1 - dry contact, closed on call for electric heat stage 1  
 2 - dry contact, closed on call for electric heat stage 2

**POOL PUMP DRY CONTACTS (PC-X: N/A)**

If pool pump control is required, use an 18-2 cable to relay a 24VAC signal to activate an external contactor:  
 CP1 - dry contacts, closed on call for pool water flow  
 CP2 - dry contacts, closed on call for pool water flow

**POOL AUXILIARY HEAT DRY CONTACTS (PC-X: N/A)**

If an auxiliary pool heating device is present, use an 18-2 cable to relay its 24VAC signal back to activate it:  
 D1 - dry contacts, closed on call for aux. pool heat  
 D2 - dry contacts, closed on call for aux. pool heat

**208/230V POWER SUPPLY CONNECTIONS**

Wire	Colour	Contactors (Label)
Line 2	Red	L2
Neutral*	-	no connection
Line 1	Black	L1

Connect "GND" to ground lug.

**OUTDOOR UNIT SIGNAL CONNECTIONS (24VAC)**

Use an 18-3 **outdoor rated** cable to connect the accessory outdoor unit's signal connections to the matching connections in the pool conditioner's upper electrical box.

**OUTDOOR UNIT POWER CONNECTIONS (230VAC)**

Use a 14-2 outdoor rated cable to connect the accessory outdoor unit's power supply terminals to the matching terminals in the pool conditioner's lower electrical box.

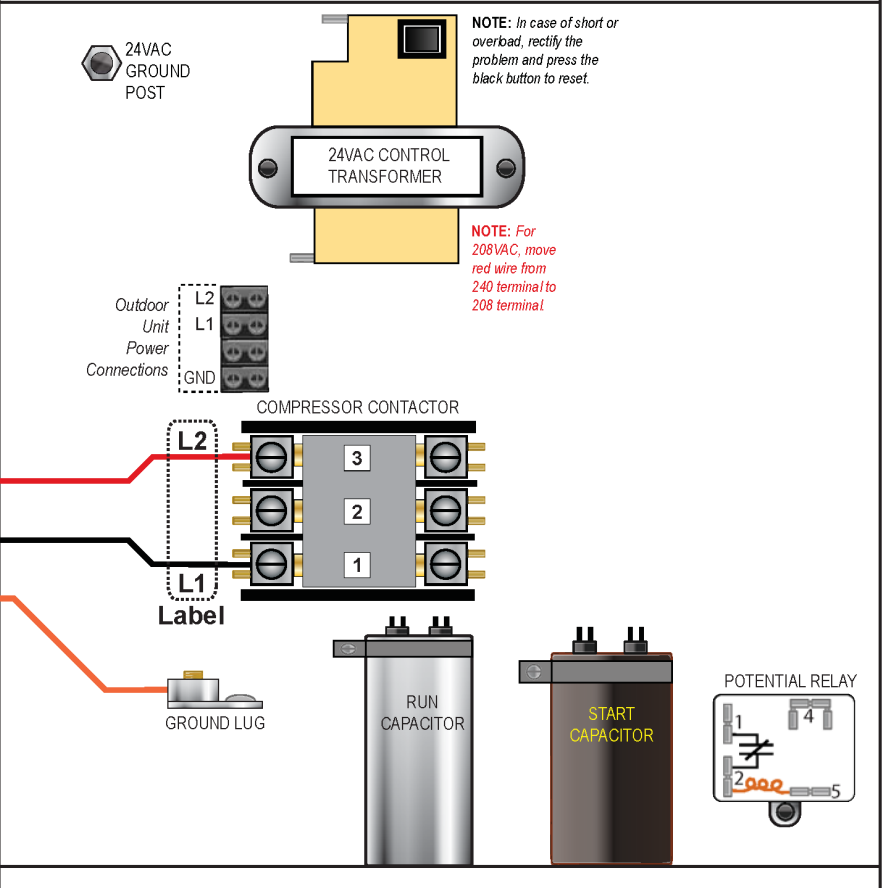
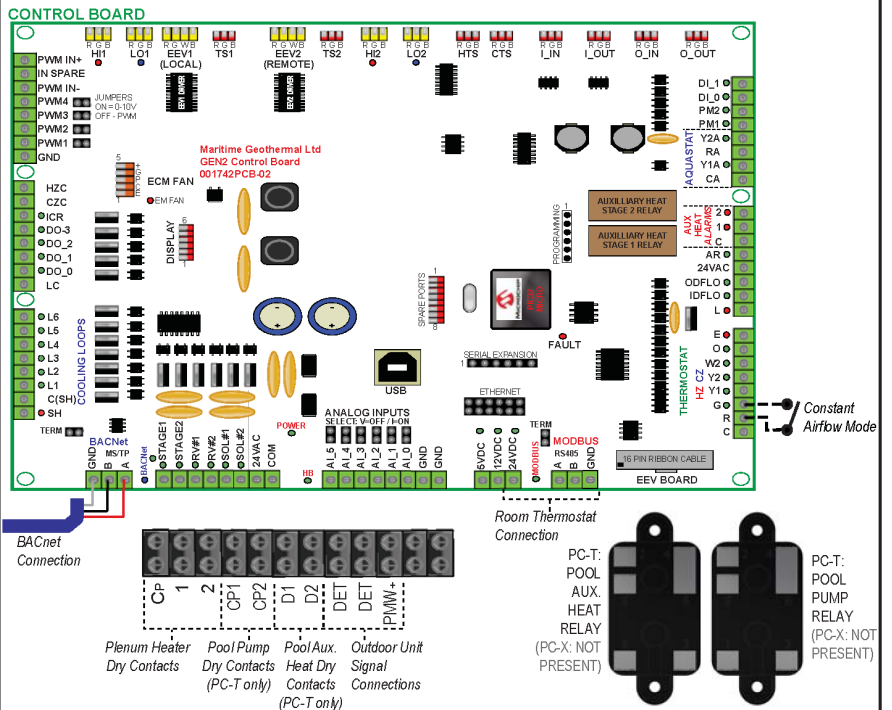

Drawn By C.GEDDES	Date 20-Oct-2011	<p>P.O. Box 2555          170 Plantation Rd.          Pettitcodiac, NB CANADA E4Z 6H4</p>
Checked By C.GEDDES	Date 20-Oct-2011	
Eng. Approved By C.GEDDES	Date 20-Oct-2011	
Mfg. Approved By	Date	
Approved By	Date	
Drawing Name PC-**-P-1S-T/X-*DE** Electrical Box Diagram		Size LET
Drawing Number 001424ELB		Drawing Rev 03
Sheet 1 / 1		

# PC-Series (GEN2) Schematic Diagram 208-3-60

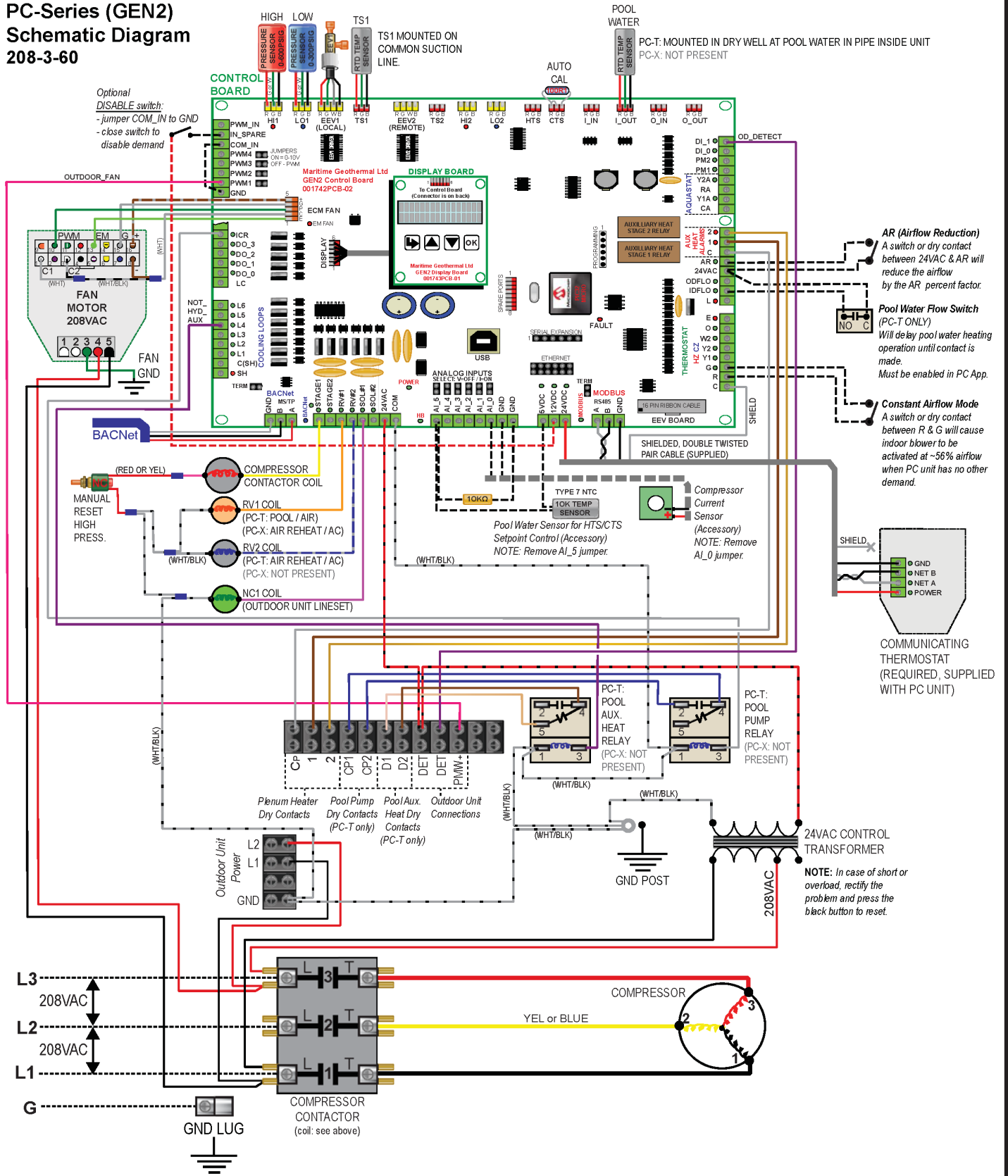

REV	ECO#	IMPL BY	APVD BY	DATE
04	000321	D. RHEAULT	D. RHEAULT	1-May-2024
03	ISSUE 05	D. RHEAULT	D. RHEAULT	11-Apr-2024
03	ISSUE 04	D. RHEAULT	D. RHEAULT	21-Sep-2023
03	ISSUE 03	D. RHEAULT	D. RHEAULT	17-May-2023
03	ISSUE 02	D. RHEAULT	D. RHEAULT	27-Sep-2021

Drawn By C. GEDDES	Date 22-Jan-2014
Checked By C. GEDDES	Date 22-Jan-2014
Eng. Approved By C. GEDDES	Date 22-Jan-2014
Mfg. Approved By	Date
Approved By	Date

P.O. Box 2555  
 170 Plantation Rd.  
 Pettitcodiac, NB CANADA E4Z 6H4

Drawing Name  
**PC-\*\*-\*-2S-T/X-KDER\***  
**Schematic Diagram**

Size LET	Drawing Number 001825SCH	Drawing Rev 04	Sheet 1 / 1
-------------	-----------------------------	-------------------	----------------

**PC-Series (GEN2)  
Electrical Box Diagram  
208-3-60**

**ROOM THERMOSTAT (REQUIRED)**

Connect the communicating thermostat directly to board with supplied shielded, double twisted pair cable:

- A - communication: use **one twisted pair**
- B - communication: use **one twisted pair**
- 24VDC - power: use **other twisted pair**
- GND - ground

**CONSTANT AIRFLOW MODE**

A switch or dry contact between R & G will activate the indoor blower at ~56% airflow when no other demand.  
R - 24VAC  
G - blower activation

**BACnet CONNECTIONS (MS/TP RS-485)**

Use a shielded, twisted pair cable to connect the optional BACnet connections to the control board.

- A - communication: use **one twisted pair**
- B - communication: use **one twisted pair**
- GND - Ground

BACnet Object	Activation
SYSTEM_G	Constant Airflow/Fan Recirculation Mode
SYSTEM_Y1	Air Reheat/Aux.Heat or Air Cool Demand
SYSTEM_O	Air Heating (OFF) / Air Cooling (ON)
SYSTEM_Y1A	Pool Water Heat Demand
SYSTEM_DH	Air Dehumidify Demand

**PLENUM HEATER DRY CONTACTS**

Use an 18-3 cable to connect the air plenum heater control board to the pool conditioner terminal strip:  
CP - 24VAC from plenum heater  
1 - dry contact, closed on call for electric heat stage 1  
2 - dry contact, closed on call for electric heat stage 2

**POOL PUMP DRY CONTACTS (PC-X: N/A)**

If pool pump control is required, use an 18-2 cable to relay a 24VAC signal to activate an external contactor:  
CP1 - dry contacts, closed on call for pool water flow  
CP2 - dry contacts, closed on call for pool water flow

**POOL AUXILIARY HEAT DRY CONTACTS (PC-X: N/A)**

If an auxiliary pool heating device is present, use an 18-2 cable to relay its 24VAC signal back to activate it:  
D1 - dry contacts, closed on call for aux. pool heat  
D2 - dry contacts, closed on call for aux. pool heat

**208V POWER SUPPLY CONNECTIONS**

Wire	Colour	Contactors (Label)
Line 3	Red	L3
Line 2	Blue	L2
Line 1	Black	L1

Connect "GND" to ground lug.

**OUTDOOR UNIT SIGNAL CONNECTIONS (24VAC)**

Use an 18-3 **outdoor rated** cable to connect the accessory outdoor unit's signal connections to the matching connections in the pool conditioner's upper electrical box.

**OUTDOOR UNIT POWER CONNECTIONS (230VAC)**

Use a 14-2 outdoor rated cable to connect the accessory outdoor unit's power supply terminals to the matching terminals in the pool conditioner's lower electrical box.

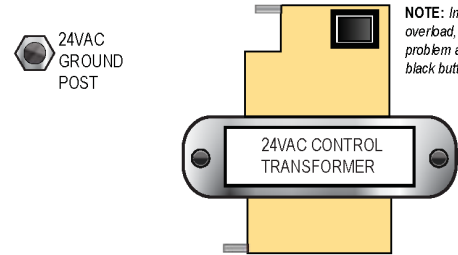
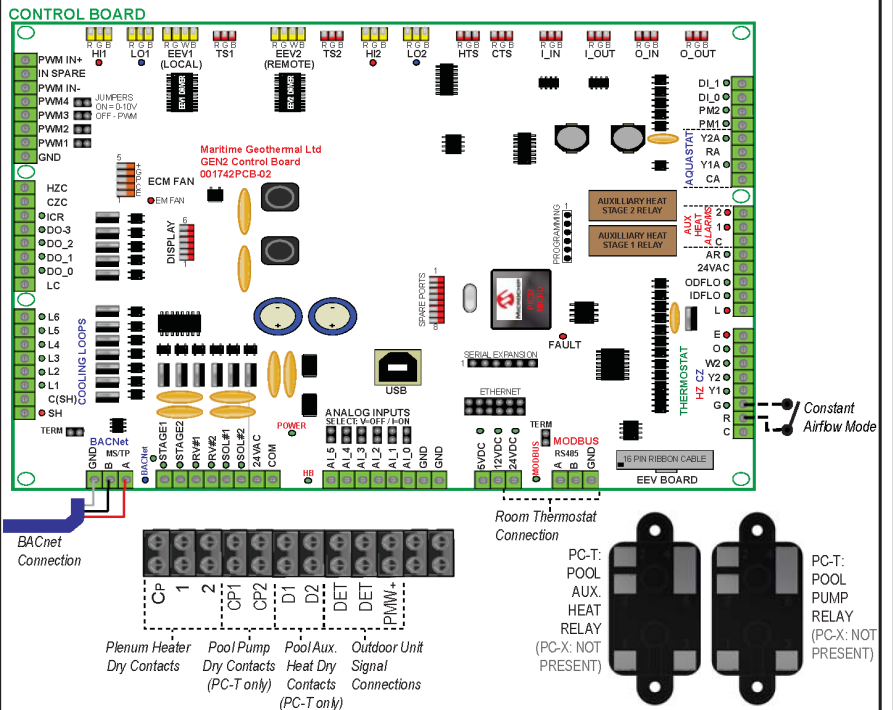

**NOTE:** In case of short or overbad, rectify the problem and press the black button to reset.

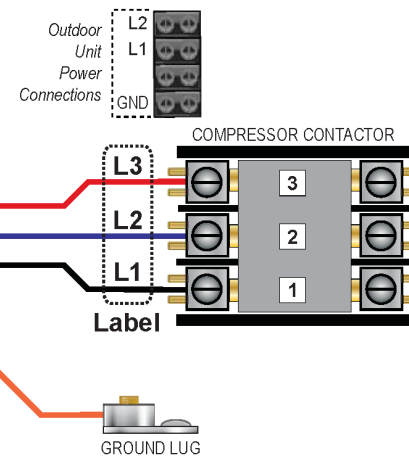

**IMPORTANT NOTE FOR 3 PHASE POWER**  
If on initial startup the compressor is noisy and not pumping, reverse L1 and L2 supply wires.

Drawn By C. GEDDES	Date 22-Jan-2014
Checked By C. GEDDES	Date 22-Jan-2014
Eng. Approved By C. GEDDES	Date 22-Jan-2014
Mfg. Approved By	Date
Approved By	Date

<b>MARITIME GEOTHERMAL LTD.</b>		P.O. Box 2555 170 Plantation Rd. Petitcodiac, NB CANADA E4Z 6H4	
Drawing Name PC-**-p-2S-T/X-*DE** Electrical Box Diagram			
Size LET	Drawing Number 001826ELB	Drawing Rev 03	Sheet 1 / 1

# PC-Series (GEN2) Schematic Diagram 460-3-60

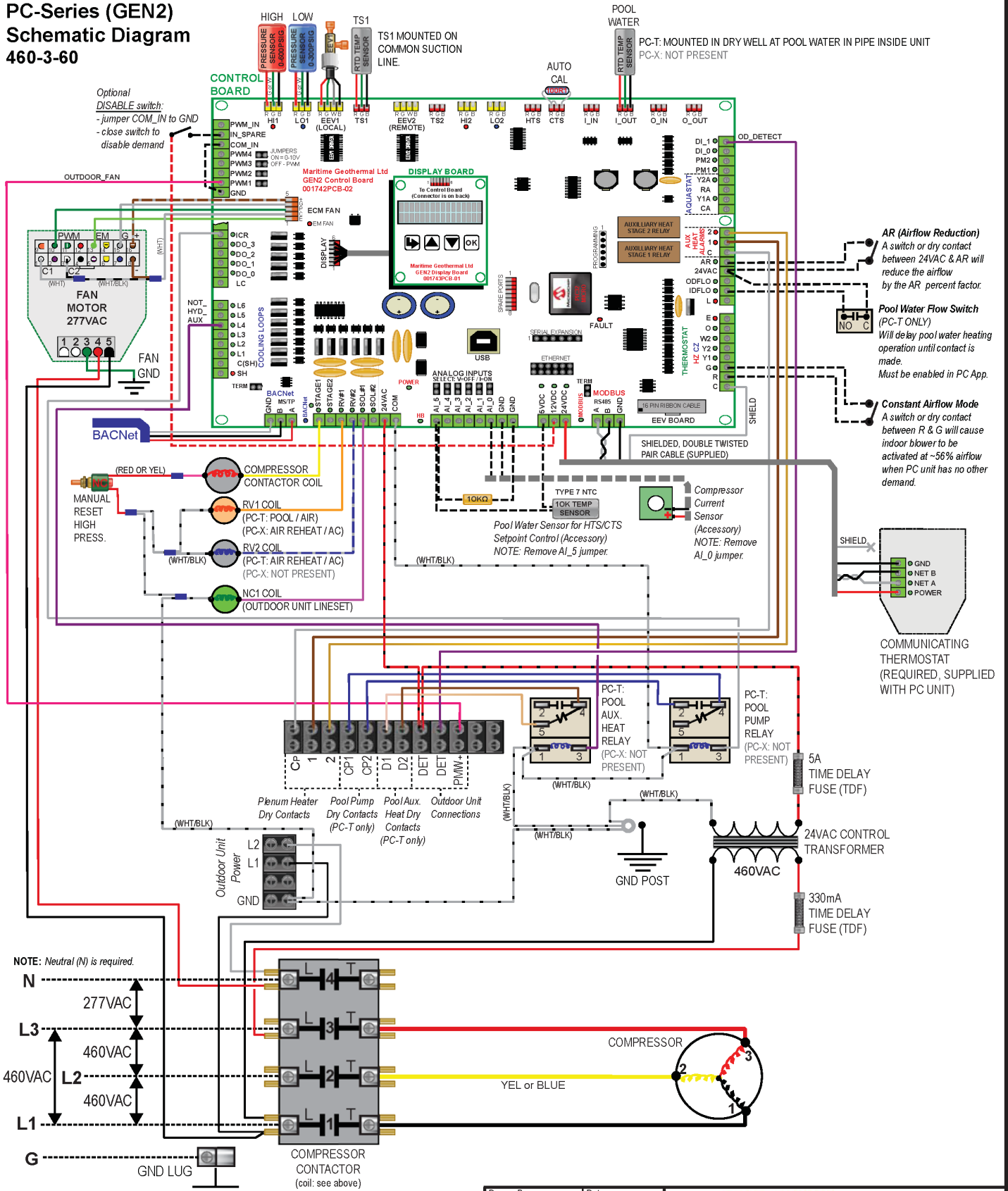

03	000321	D. RHEAULT	D. RHEAULT	1-May-2024	Drawn By D. RHEAULT	Date 11-Apr-2018	<b>MARITIME GEOTHERMAL LTD.</b> P.O. Box 2555 170 Plantation Rd. Pettitcodiac, NB CANADA E4Z 6H4 <b>Drawing Name</b> <b>PC-**-*-4S-T/X-KDER*</b> <b>Schematic Diagram</b>	
02	ISSUE 05	D. RHEAULT	D. RHEAULT	11-Apr-2024	Checked By D. RHEAULT	Date 11-Apr-2018		
02	ISSUE 04	D. RHEAULT	D. RHEAULT	21-Sep-2023	Eng. Approved By D. RHEAULT	Date 11-Apr-2018		
02	ISSUE 03	D. RHEAULT	D. RHEAULT	17-May-2023	Mfg. Approved By	Date		
02	ISSUE 02	D. RHEAULT	D. RHEAULT	27-Sep-2021	Approved By	Date		
REV	ECO#	IMPL BY	APVD BY	DATE	Size LET	Drawing Number 002292SCH	Drawing Rev 03	Sheet 1 / 1

**PC-Series (GEN2)**  
**Electrical Box Diagram**  
**460-3-60**

**ROOM THERMOSTAT (REQUIRED)**

Connect the communicating thermostat directly to board with supplied shielded, double twisted pair cable:

- A - communication: use **one twisted pair**
- B - power: use **other twisted pair**

**CONSTANT AIRFLOW MODE**

A switch or dry contact between R & G will activate the indoor blower at ~56% airflow when no other demand.  
 R - 24VAC  
 G - blower activation

**BACNet CONNECTIONS (MS/TP RS-485)**

Use a shielded, twisted pair cable to connect the optional BACNet connections to the control board.

- A - communication: use **one twisted pair**
- B - Ground

BACNet Object	Activation
SYSTEM_G	Constant Airflow/Fan Recirculation Mode
SYSTEM_Y1	Air Reheat/Aux.Heat or Air Cool Demand
SYSTEM_O	Air Heating (OFF) / Air Cooling (ON)
SYSTEM_Y1A	Pool Water Heat Demand
SYSTEM_DH	Air Dehumidify Demand

**PLENUM HEATER DRY CONTACTS**

Use an 18-3 cable to connect the air plenum heater control board to the pool conditioner terminal strip:  
 CP - 24VAC from plenum heater  
 1 - dry contact, closed on call for electric heat stage 1  
 2 - dry contact, closed on call for electric heat stage 2

**POOL PUMP DRY CONTACTS (PC-X: N/A)**

If pool pump control is required, use an 18-2 cable to relay a 24VAC signal to activate an external contactor:  
 CP1 - dry contacts, closed on call for pool water flow  
 CP2 - dry contacts, closed on call for pool water flow

**POOL AUXILIARY HEAT DRY CONTACTS**

If an auxiliary pool heating device is present, use an 18-2 cable to relay its 24VAC signal back to activate it:  
 D1 - dry contacts, closed on call for aux. pool heat  
 D2 - dry contacts, closed on call for aux. pool heat

**460/277V POWER SUPPLY CONNECTIONS**

\*NOTE: Neutral (N) is required.

Wire	Colour	Contactors (Label)
Neutral*	White	N*
Line 3	Red	L3
Line 2	Blue	L2
Line 1	Black	L1

Connect "GND" to ground lug.

**OUTDOOR UNIT SIGNAL CONNECTIONS (24VAC)**

Use an 18-3 **outdoor rated** cable to connect the accessory outdoor unit's signal connections to the matching connections in the pool conditioner's upper electrical box.

**OUTDOOR UNIT POWER CONNECTIONS (230VAC)**

Use a 14-2 outdoor rated cable to connect the accessory outdoor unit's power supply terminals to the matching terminals in the pool conditioner's lower electrical box.

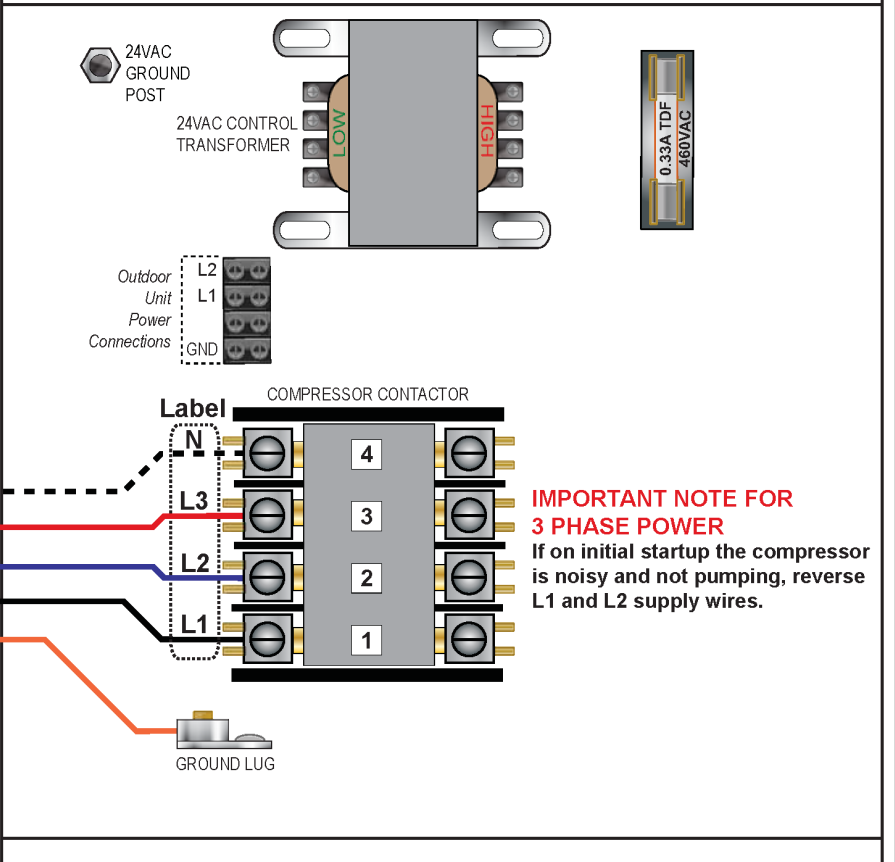
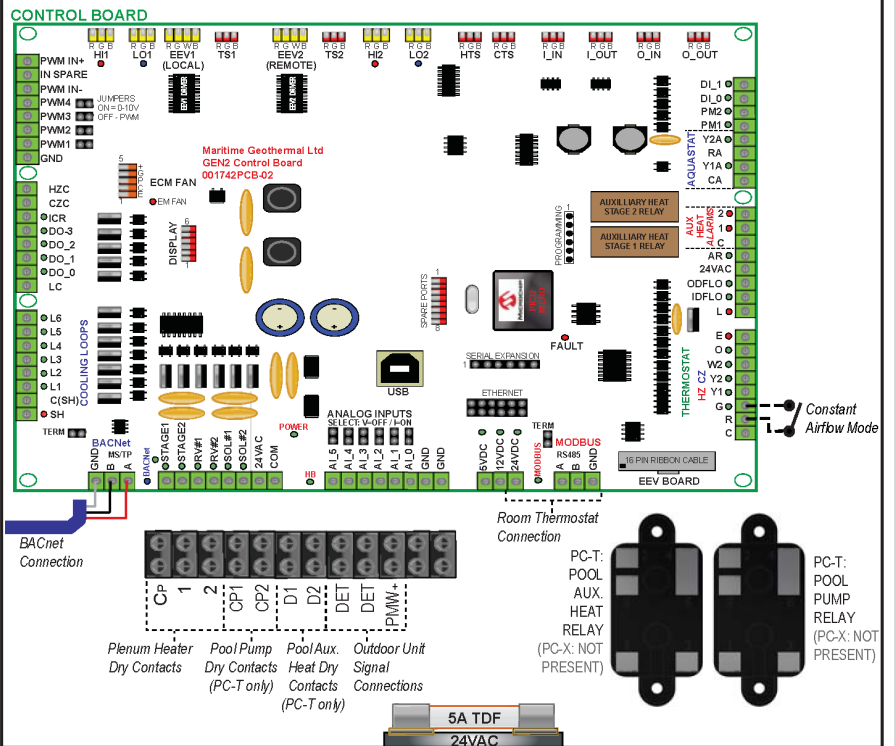

Drawn By D. RHEAULT	Date 16-Mar-2018	<b>MARITIME GEOTHERMAL LTD.</b>	P.O. Box 2555 170 Plantation Rd. Petitcodiac, NB CANADA E4Z 6H4
Checked By D. RHEAULT	Date 16-Mar-2018		
Eng. Approved By D. RHEAULT	Date 16-Mar-2018	Drawing Name PC-**-p-4S-T/X-*DE** Electrical Box Diagram	
Mfg. Approved By	Date	Approved By	Date
Size LET	Drawing Number 002293ELB	Drawing Rev 02	Sheet 1 / 1



# PC-Series (GEN2) Schematic Diagram 220-1-50

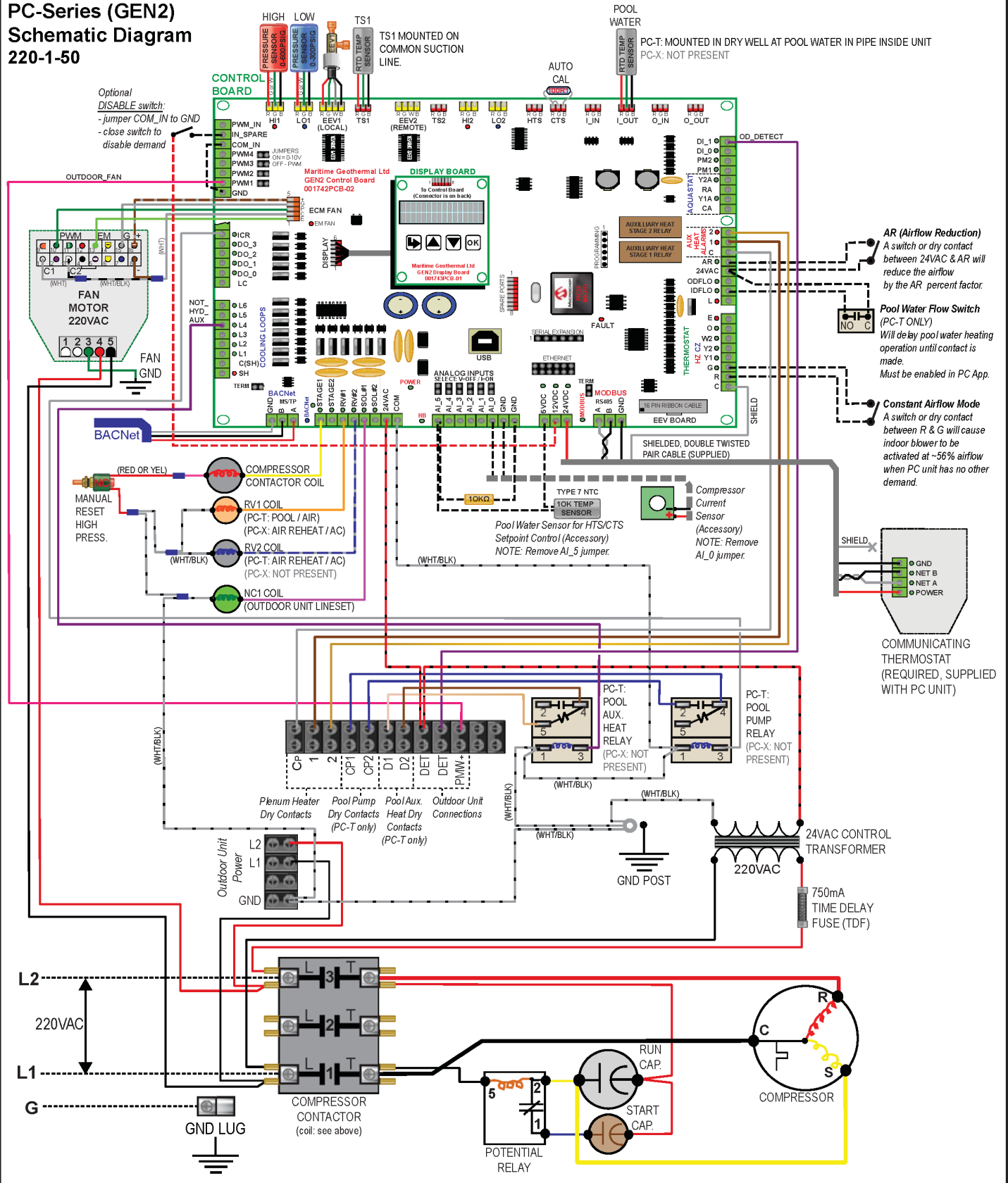

04	000321	D. RHEAULT	D. RHEAULT	1-May-2024	Drawn By C. GEDDES	Date 28-Feb-2011	P.O. Box 2555 170 Plantation Rd. Petitcodiac, NB CANADA E4Z 6H4 Drawing Name <b>PC-**-*-6S-T/X-KDER*</b> Schematic Diagram
03	ISSUE 05	D. RHEAULT	D. RHEAULT	11-Apr-2024	Checked By C. GEDDES	Date 28-Feb-2011	
03	ISSUE 04	D. RHEAULT	D. RHEAULT	21-Sep-2023	Eng. Approved By C. GEDDES	Date 28-Feb-2011	
03	ISSUE 03	D. RHEAULT	D. RHEAULT	17-May-2023	Mfg. Approved By	Date	
03	ISSUE 02	D. RHEAULT	D. RHEAULT	27-Sep-2021	Approved By	Date	
REV	ECO#	IMPL BY	APVD BY	DATE			Size LET Drawing Number 001425SCH Drawing Rev 04 Sheet 1 / 1

**PC-Series (GEN2)  
Electrical Box Diagram  
220-1-50**

**ROOM THERMOSTAT (REQUIRED)**

Connect the communicating thermostat directly to board with supplied shielded, double twisted pair cable:

- A : communication: use **one twisted pair**
- B : power: use **other twisted pair**

**CONSTANT AIRFLOW MODE**

A switch or dry contact between R & G will activate the indoor blower at ~56% airflow when no other demand.  
R - 24VAC  
G - blower activation

**BACNet CONNECTIONS (MS/TP RS-485)**

Use a shielded, twisted pair cable to connect the optional BACNet connections to the control board.

- A : communication: use **one twisted pair**
- B : GND - Ground

BACNet Object	Activation
SYSTEM_G	Constant Airflow/Fan Recirculation Mode
SYSTEM_Y1	Air Reheat/Aux.Heat or Air Cool Demand
SYSTEM_O	Air Heating (OFF) / Air Cooling (ON)
SYSTEM_Y1A	Pool Water Heat Demand
SYSTEM_DH	Air Dehumidify Demand

**PLENUM HEATER DRY CONTACTS**

Use an 18-3 cable to connect the air plenum heater control board to the pool conditioner terminal strip:  
CP - 24VAC from plenum heater  
1 - dry contact, closed on call for electric heat stage 1  
2 - dry contact, closed on call for electric heat stage 2

**POOL PUMP DRY CONTACTS (PC-X: N/A)**

If pool pump control is required, use an 18-2 cable to relay a 24VAC signal to activate an external contactor:  
CP1 : dry contacts, closed on call for pool water flow

**POOL AUXILIARY HEAT DRY CONTACTS (PC-X: N/A)**

If an auxiliary pool heating device is present, use an 18-2 cable to relay its 24VAC signal back to activate it:  
D1 : dry contacts, closed on call for aux. pool heat  
D2 :

**220V POWER SUPPLY CONNECTIONS**

Wire	Colour	Contactors (Label)
Line 2	Red	L2
Neutral*	-	no connection
Line 1	Black	L1

Connect "GND" to ground lug.

**OUTDOOR UNIT SIGNAL CONNECTIONS (24VAC)**

Use an 18-3 **outdoor rated** cable to connect the accessory outdoor unit's signal connections to the matching connections in the pool conditioner's upper electrical box.

**OUTDOOR UNIT POWER CONNECTIONS (230VAC)**

Use a 14-2 outdoor rated cable to connect the accessory outdoor unit's power supply terminals to the matching terminals in the pool conditioner's lower electrical box.

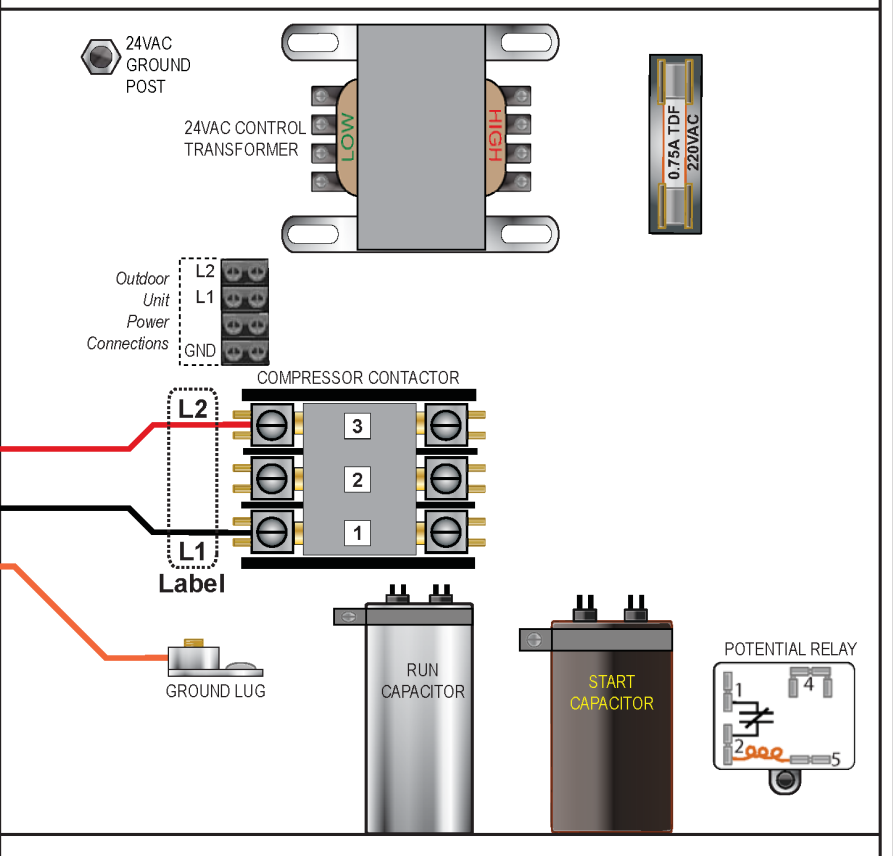
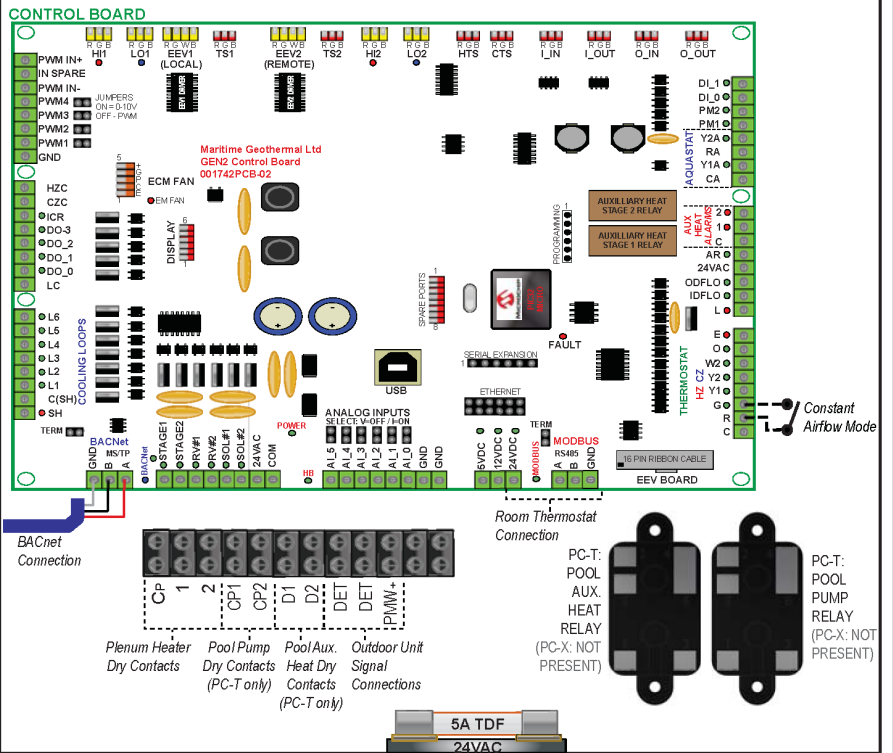

Drawn By C.GEDDES	Date 28-Feb-2011	<p>P.O. Box 2555 170 Plantation Rd. Pettitcodiac, NB CANADA E4Z 6H4</p>
Checked By C.GEDDES	Date 28-Feb-2011	
Eng. Approved By C.GEDDES	Date 28-Feb-2011	
Mfg. Approved By	Date	
Approved By	Date	
Drawing Name PC-**-P-6S-T/X-*DE** Electrical Box Diagram		Size LET
Drawing Number 001426ELB		Drawing Rev 03
Sheet 1 / 1		

# PC-Series (GEN2) Schematic Diagram 380-3-50

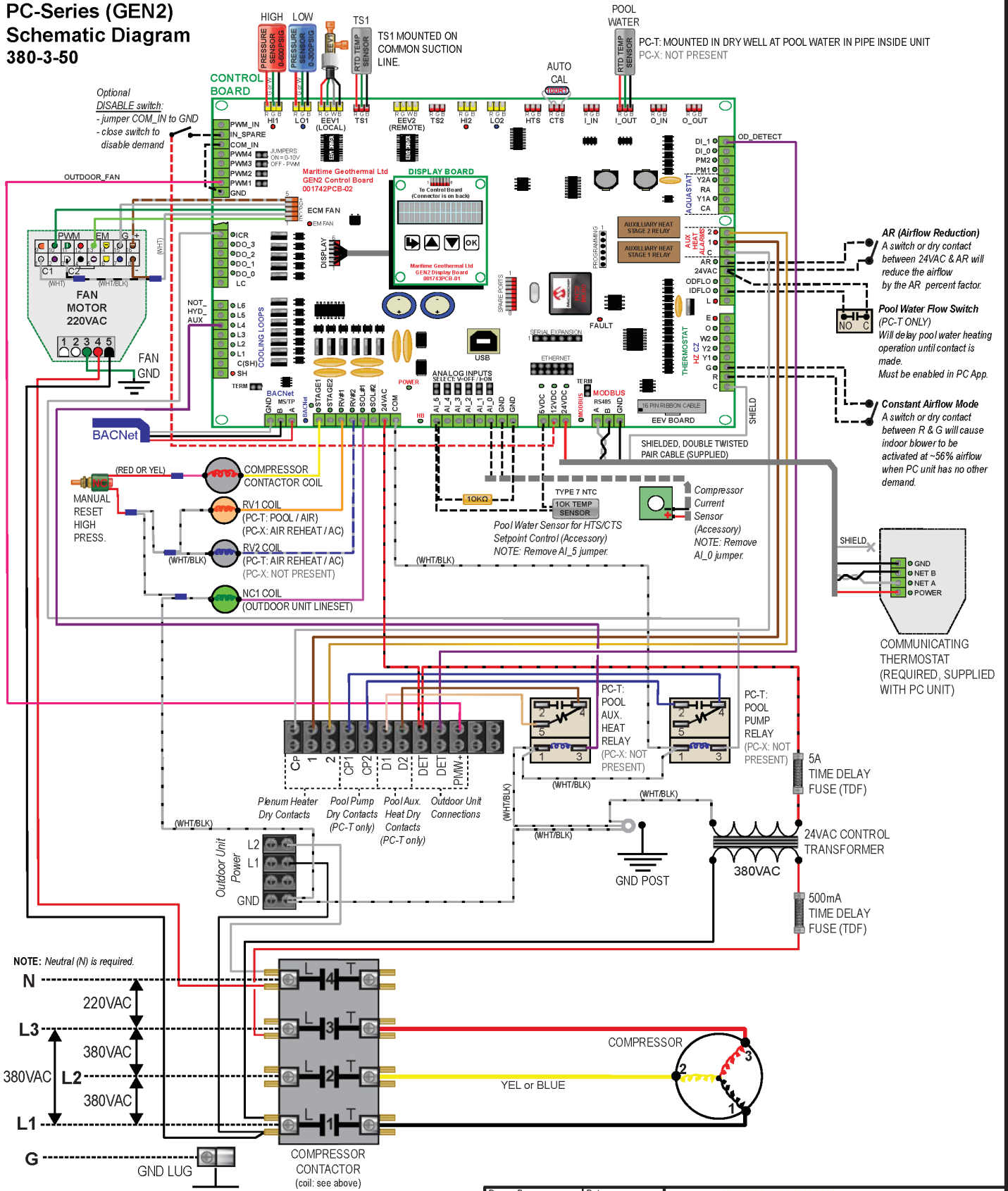

03	000321	D. RHEAULT	D. RHEAULT	1-May-2024	Drawn By D. RHEAULT	Date 11-Apr-2018	<b>MARITIME GEOTHERMAL LTD.</b> P.O. Box 2555 170 Plantation Rd. Pettitcodiac, NB CANADA E4Z 6H4 Drawing Name <b>PC-**-*-7S-T/X-KDER*</b> Schematic Diagram	
02	ISSUE 05	D. RHEAULT	D. RHEAULT	11-Apr-2024	Checked By D. RHEAULT	Date 11-Apr-2018		
02	ISSUE 04	D. RHEAULT	D. RHEAULT	21-Sep-2023	Eng. Approved By D. RHEAULT	Date 11-Apr-2018		
02	ISSUE 03	D. RHEAULT	D. RHEAULT	17-May-2023	Mfg. Approved By	Date		
02	ISSUE 02	D. RHEAULT	D. RHEAULT	27-Sep-2021	Approved By	Date		
REV	ECO#	IMPL BY	APVD BY	DATE	Size LET	Drawing Number 002294SCH	Drawing Rev 03	Sheet 1 / 1

**PC-Series (GEN2)  
Electrical Box Diagram  
380-3-50**

**ROOM THERMOSTAT (REQUIRED)**

Connect the communicating thermostat directly to board with supplied shielded, double twisted pair cable:

- A : communication: use **one twisted pair**
- B : power: use **other twisted pair**

**CONSTANT AIRFLOW MODE**

A switch or dry contact between R & G will activate the indoor blower at ~56% airflow when no other demand.  
R - 24VAC  
G - blower activation

**BACNet CONNECTIONS (MS/TP RS-485)**

Use a shielded, twisted pair cable to connect the optional BACNet connections to the control board.

- A : communication: use **one twisted pair**
- B : GND - Ground

BACNet Object	Activation
SYSTEM_G	Constant Airflow/Fan Recirculation Mode
SYSTEM_Y1	Air Reheat/Aux.Heat or Air Cool Demand
SYSTEM_O	Air Heating (OFF) / Air Cooling (ON)
SYSTEM_Y1A	Pool Water Heat Demand
SYSTEM_DH	Air Dehumidify Demand

**PLENUM HEATER DRY CONTACTS**

Use an 18-3 cable to connect the air plenum heater control board to the pool conditioner terminal strip:  
CP - 24VAC from plenum heater  
1 - dry contact, closed on call for electric heat stage 1  
2 - dry contact, closed on call for electric heat stage 2

**POOL PUMP DRY CONTACTS (PC-X: N/A)**

If pool pump control is required, use an 18-2 cable to relay a 24VAC signal to activate an external contactor:  
CP1 : dry contacts, closed on call for pool water flow  
CP2 :

**POOL AUXILIARY HEAT DRY CONTACTS**

If an auxiliary pool heating device is present, use an 18-2 cable to relay its 24VAC signal back to activate it:  
D1 : dry contacts, closed on call for aux. pool heat  
D2 :

**380/220V POWER SUPPLY CONNECTIONS**

\*NOTE: Neutral (N) is required.

Wire	Colour	Contactors (Label)
Neutral*	White	N*
Line 3	Red	L3
Line 2	Blue	L2
Line 1	Black	L1

Connect "GND" to ground lug.

**OUTDOOR UNIT SIGNAL CONNECTIONS (24VAC)**

Use an 18-3 **outdoor rated** cable to connect the accessory outdoor unit's signal connections to the matching connections in the pool conditioner's upper electrical box.

**OUTDOOR UNIT POWER CONNECTIONS (230VAC)**

Use a 14-2 outdoor rated cable to connect the accessory outdoor unit's power supply terminals to the matching terminals in the pool conditioner's lower electrical box.

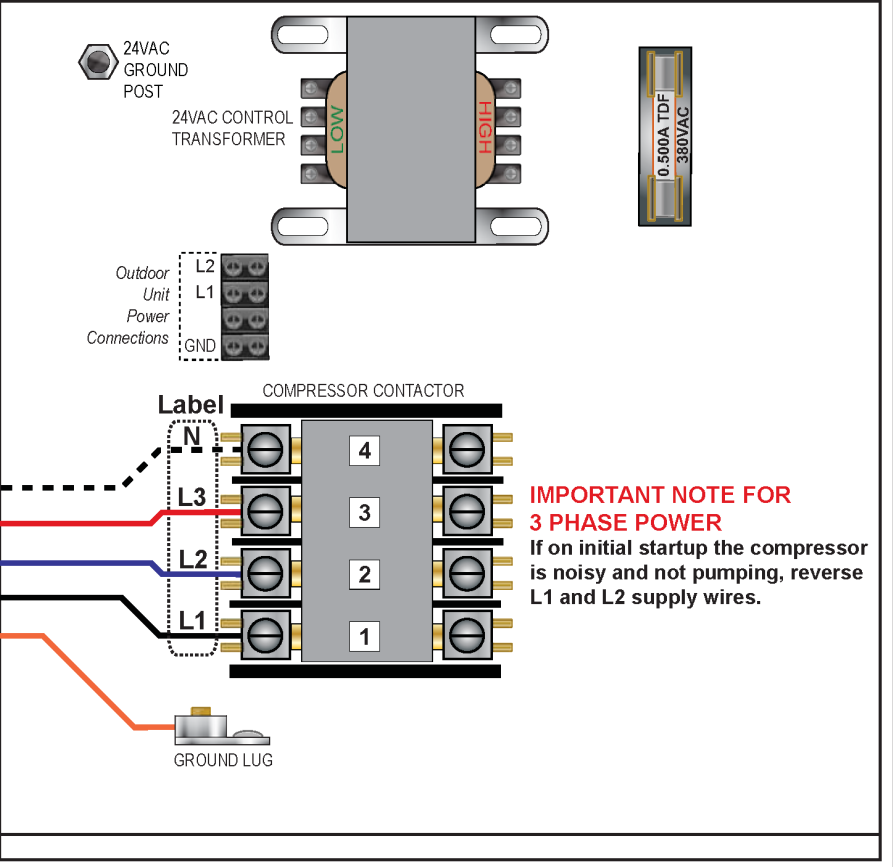
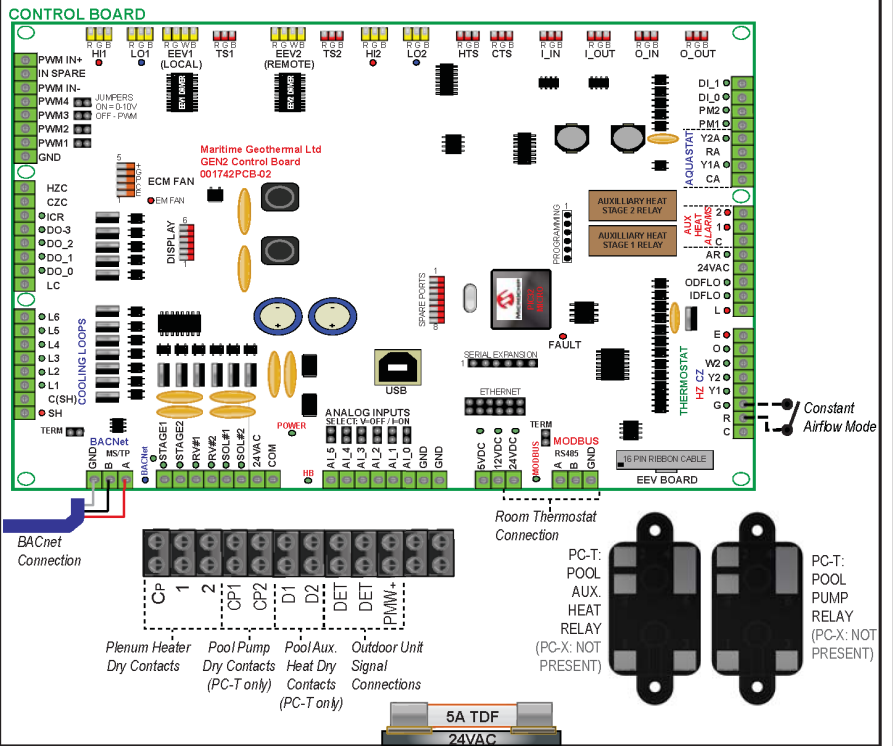

**IMPORTANT NOTE FOR 3 PHASE POWER**  
If on initial startup the compressor is noisy and not pumping, reverse L1 and L2 supply wires.

Drawn By D. RHEAULT	Date 16-Mar-2018		P.O. Box 2555 170 Plantation Rd. Pettitcodiac, NB CANADA E4Z 6H4	
Checked By D. RHEAULT	Date 16-Mar-2018		Drawing Name PC-**-p-7S-T/X-*DE** Electrical Box Diagram	
Eng. Approved By D. RHEAULT	Date 16-Mar-2018		Size LET	Drawing Number 002295ELB
Mfg. Approved By	Date		Drawing Rev 02	Sheet 1 / 1
Approved By	Date			

# PC Outdoor Condenser (AC2-Series) 4-Fan Schematic Diagram

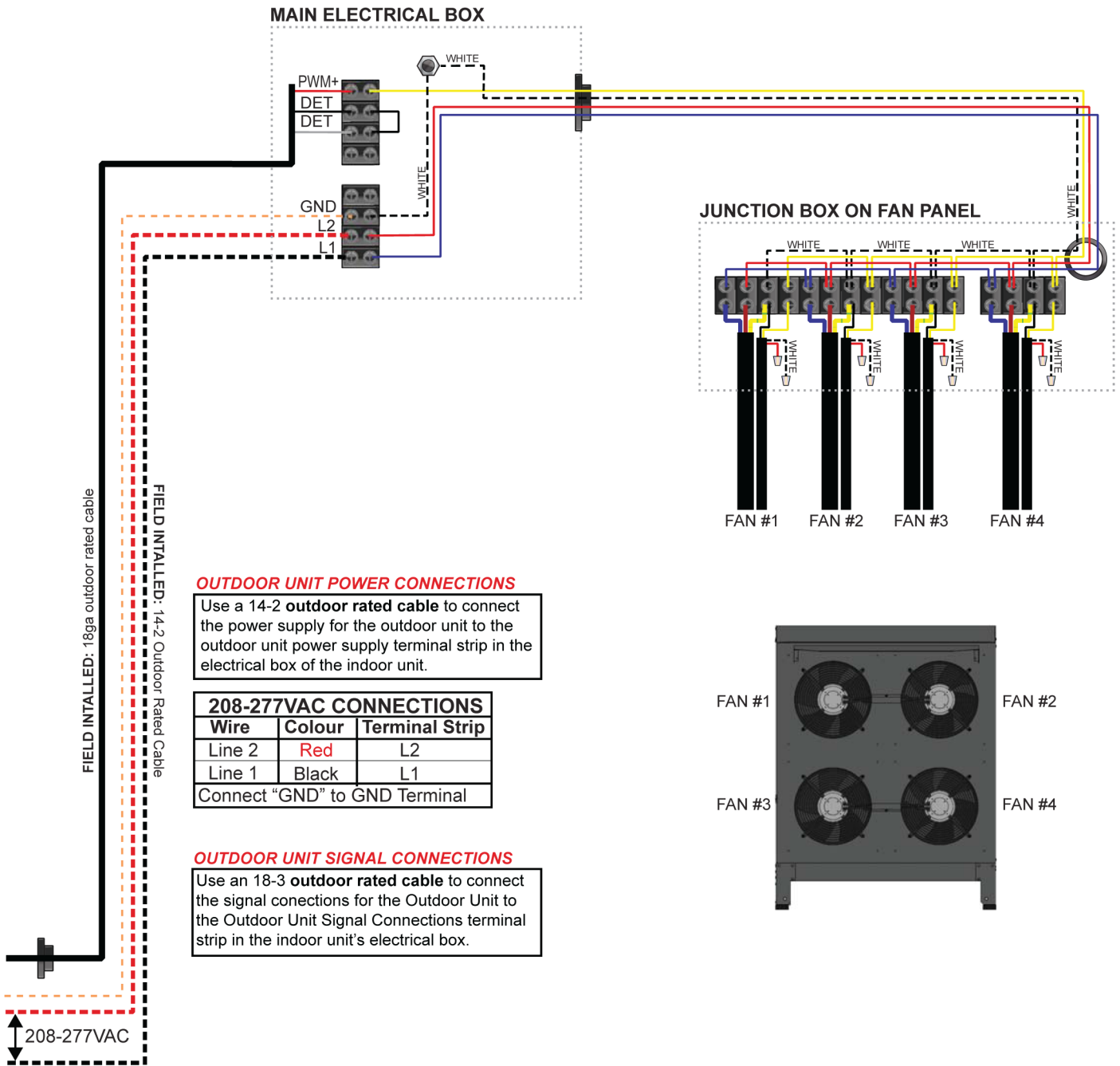

**OUTDOOR UNIT POWER CONNECTIONS**  
Use a 14-2 outdoor rated cable to connect the power supply for the outdoor unit to the outdoor unit power supply terminal strip in the electrical box of the indoor unit.

208-277VAC CONNECTIONS		
Wire	Colour	Terminal Strip
Line 2	Red	L2
Line 1	Black	L1
Connect "GND" to GND Terminal		

**OUTDOOR UNIT SIGNAL CONNECTIONS**  
Use an 18-3 outdoor rated cable to connect the signal connections for the Outdoor Unit to the Outdoor Unit Signal Connections terminal strip in the indoor unit's electrical box.

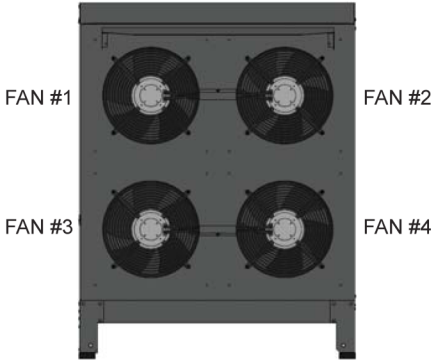

Connect power and signal wires to matching terminal strip connectors in electrical box of indoor unit.

					Drawn By D. RHEAULT Date 19-Apr-2018	P.O. Box 2555 170 Plantation Rd. Petitcodiac, NB CANADA E4Z 6H4
					Checked By D. RHEAULT Date 19-Apr-2018	
					Eng. Approved By D. RHEAULT Date 19-Apr-2018	Drawing Name  AC2 4-Fan Schematic Diagram
					Mfg. Approved By Date	
02	000275	D. RHEAULT	D. RHEAULT	1-Oct-2021	Approved By	Size LET
01	Initial Release	D. RHEAULT	D. RHEAULT	19-Apr-2018	Date	Drawing Number 002262SCH
REV	ECO#	IMPL BY	APVD BY	DATE		Drawing Rev 02
						Sheet 1 / 1

# PC-T Refrigeration Circuit - Pool Water Heat Mode

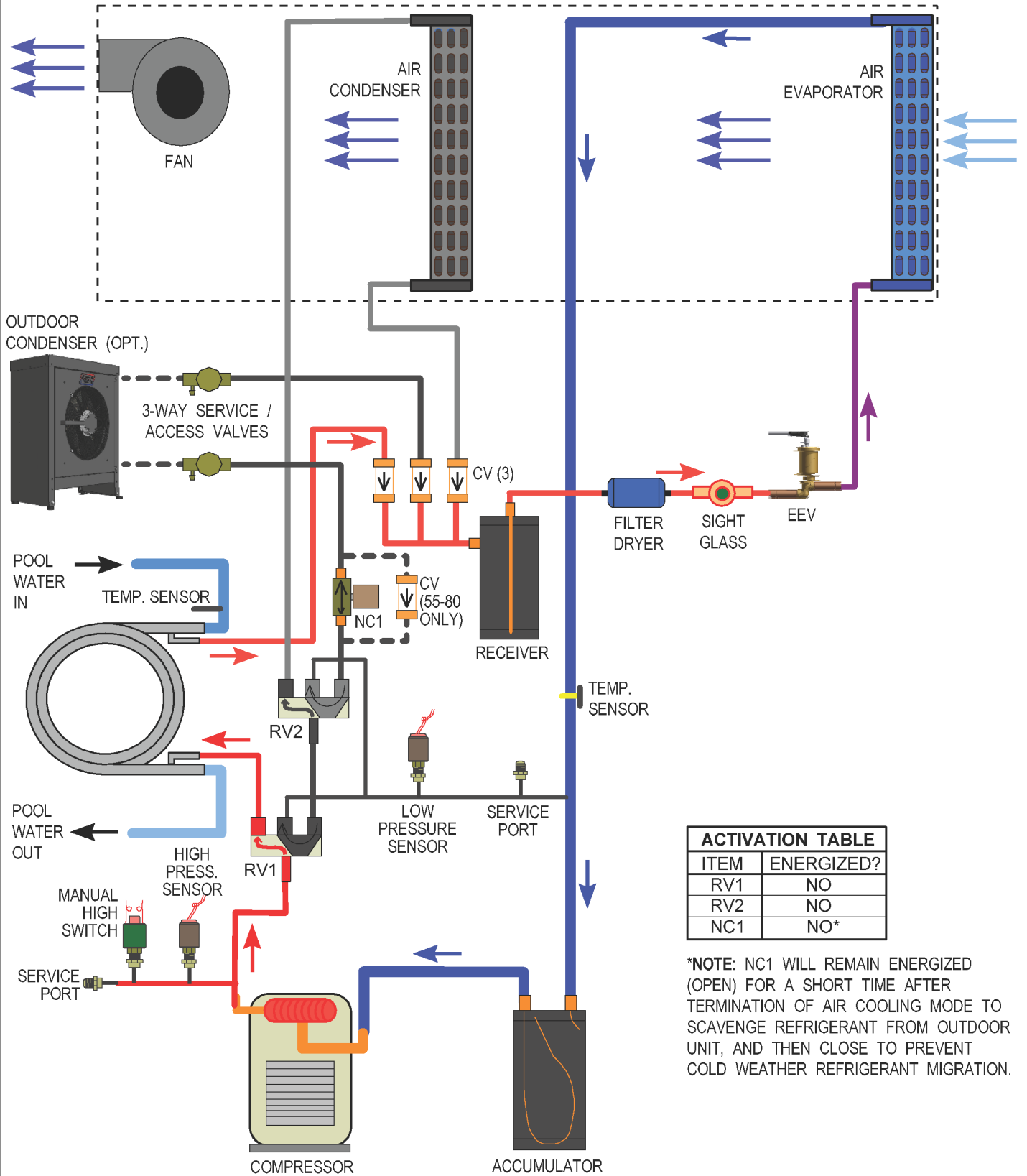

ACTIVATION TABLE	
ITEM	ENERGIZED?
RV1	NO
RV2	NO
NC1	NO*

\*NOTE: NC1 WILL REMAIN ENERGIZED (OPEN) FOR A SHORT TIME AFTER TERMINATION OF AIR COOLING MODE TO SCAVENGE REFRIGERANT FROM OUTDOOR UNIT, AND THEN CLOSE TO PREVENT COLD WEATHER REFRIGERANT MIGRATION.

05	000316	D. RHEAULT	D. RHEAULT	01 SEP 23	Drawn By Chris Geddes	Date 09 JAN 07	MARITIME GEOTHERMAL LTD. 170 Plantation Rd. Petitcodiac, NB E4Z 6H4	
04	000284	D. RHEAULT	D. RHEAULT	20 JAN 21	Checked By Chris Geddes	Date 09 JAN 07		
03	000271	D. RHEAULT	D. RHEAULT	06 MAR 19	Approved By Chris Geddes (ENG)	Date 09 JAN 07	Drawing Name PC-***-T Refrigeration Circuit Diagram - Pool Water Heat Mode	
02	000236	D. RHEAULT	D. RHEAULT	01 MAY 15	Approved By (MFG)	Date		
01	Initial Release	C. GEDDES	C. GEDDES	09 JAN 07	Approved By	Date	Size A	
REV	ECO #	IMPL BY	APVD BY	DATE			Drawing Number 000352RCD	
							REV 05	SHEET 1 of 1

# PC-T Refrigeration Circuit - Air Reheat Mode

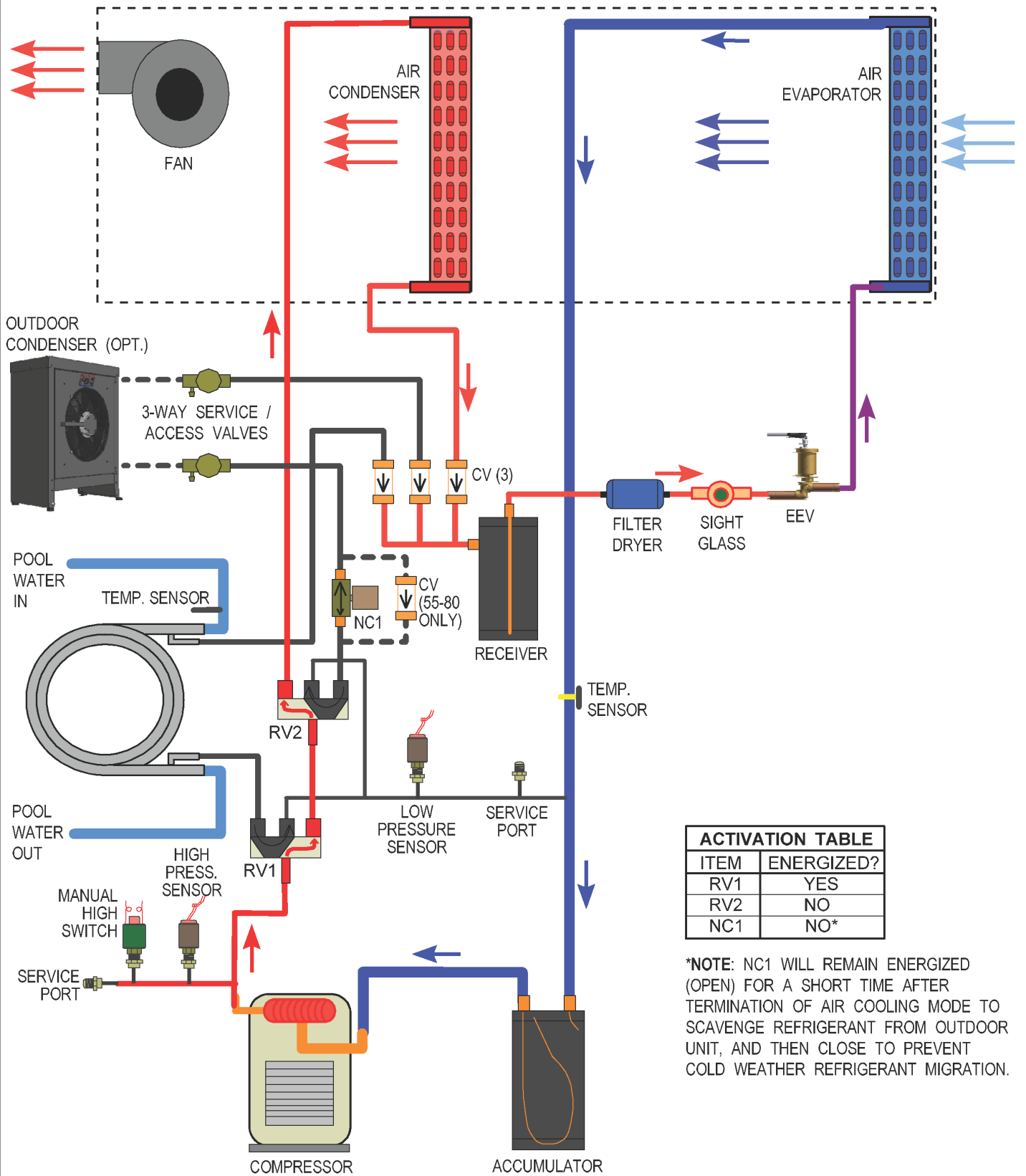

ACTIVATION TABLE	
ITEM	ENERGIZED?
RV1	YES
RV2	NO
NC1	NO*

\*NOTE: NC1 WILL REMAIN ENERGIZED (OPEN) FOR A SHORT TIME AFTER TERMINATION OF AIR COOLING MODE TO SCAVENGE REFRIGERANT FROM OUTDOOR UNIT, AND THEN CLOSE TO PREVENT COLD WEATHER REFRIGERANT MIGRATION.

05	000316	D. RHEAULT	D. RHEAULT	01 SEP 23	Drawn By Chris Geddes	Date 09 JAN 07	MARITIME GEOTHERMAL LTD. 170 Plantation Rd. Petitcodiac, NB E4Z 6H4
04	000284	D. RHEAULT	D. RHEAULT	20 JAN 21	Checked By Chris Geddes	Date 09 JAN 07	
03	000271	D. RHEAULT	D. RHEAULT	06 MAR 19	Approved By Chris Geddes (ENG)	Date 09 JAN 07	Drawing Name PC-***T Refrigeration Circuit Diagram - Air Reheat Mode
02	000236	D. RHEAULT	D. RHEAULT	01 MAY 15	Approved By (MFG)	Date	
01	Initial Release	C. GEDDES	C. GEDDES	09 JAN 07	Approved By	Date	Size A
REV	ECO #	IMPL BY	APVD BY	DATE	Approved By	Date	Drawing Number 000353RCD
							REV 05
							SHEET 1 of 1

# PC-T Refrigeration Circuit - Heat Rejection Mode

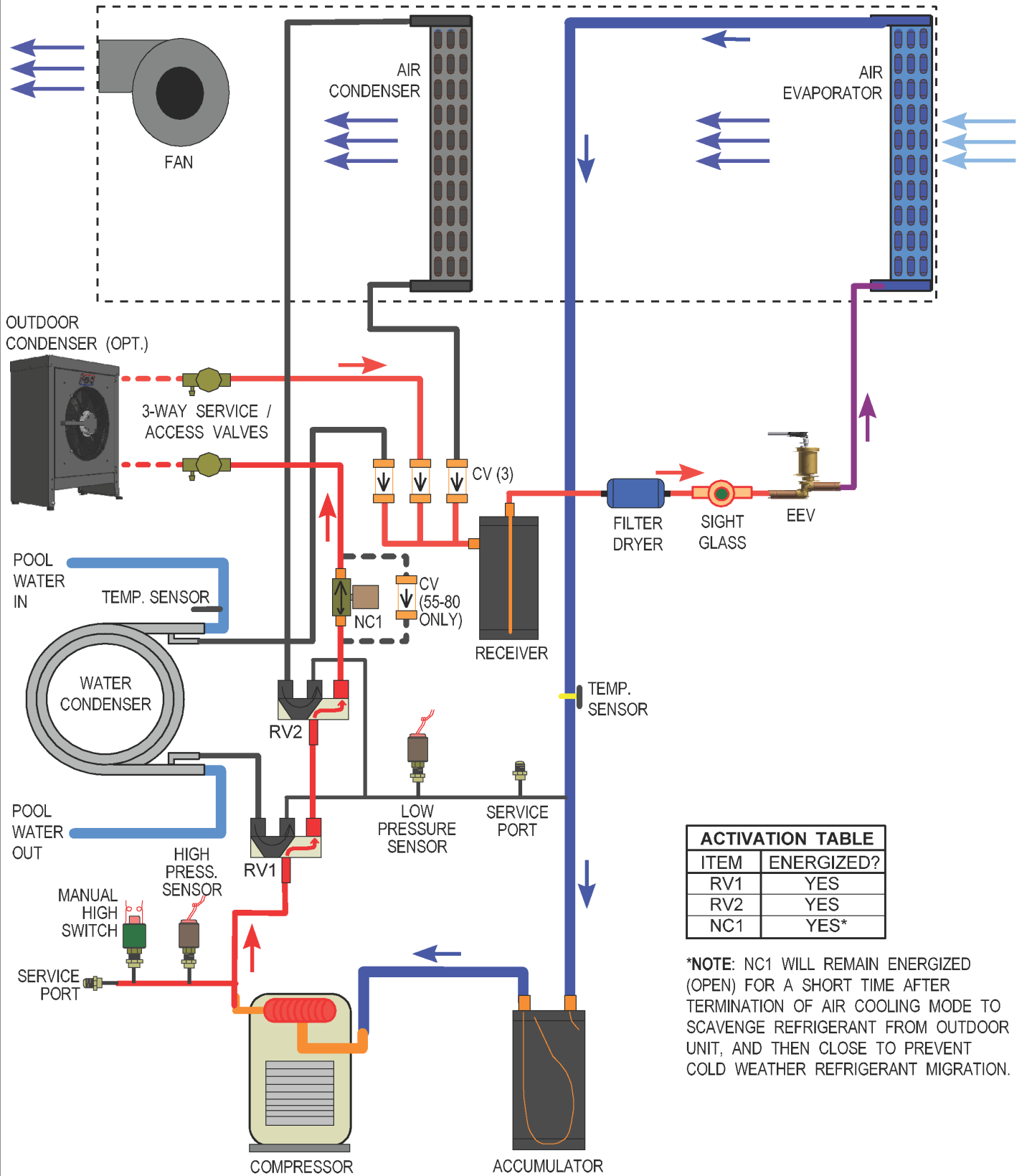

ACTIVATION TABLE	
ITEM	ENERGIZED?
RV1	YES
RV2	YES
NC1	YES*

\*NOTE: NC1 WILL REMAIN ENERGIZED (OPEN) FOR A SHORT TIME AFTER TERMINATION OF AIR COOLING MODE TO SCAVENGE REFRIGERANT FROM OUTDOOR UNIT, AND THEN CLOSE TO PREVENT COLD WEATHER REFRIGERANT MIGRATION.

05	000316	D. RHEAULT	D. RHEAULT	01 SEP 23	Drawn By Chris Geddes	Date 09 JAN 07	MARITIME GEOTHERMAL LTD. 170 Plantation Rd. Petitcodiac, NB E4Z 6H4	
04	000284	D. RHEAULT	D. RHEAULT	20 JAN 21	Checked By Chris Geddes	Date 09 JAN 07		
03	000271	D. RHEAULT	D. RHEAULT	06 MAR 19	Approved By Chris Geddes (ENG)	Date 09 JAN 07	Drawing Name PC-***T Refrigeration Circuit Diagram - Heat Rejection Mode	
02	000236	D. RHEAULT	D. RHEAULT	01 MAY 15	Approved By (MFG)	Date		
01	Initial Release	C. GEDDES	C. GEDDES	09 JAN 07	Approved By	Date	Size A	
REV	ECO #	IMPL BY	APVD BY	DATE			Drawing Number 000354RCD	
							REV 05	SHEET 1 of 1



# PC-X Refrigeration Circuit - Air Reheat Mode

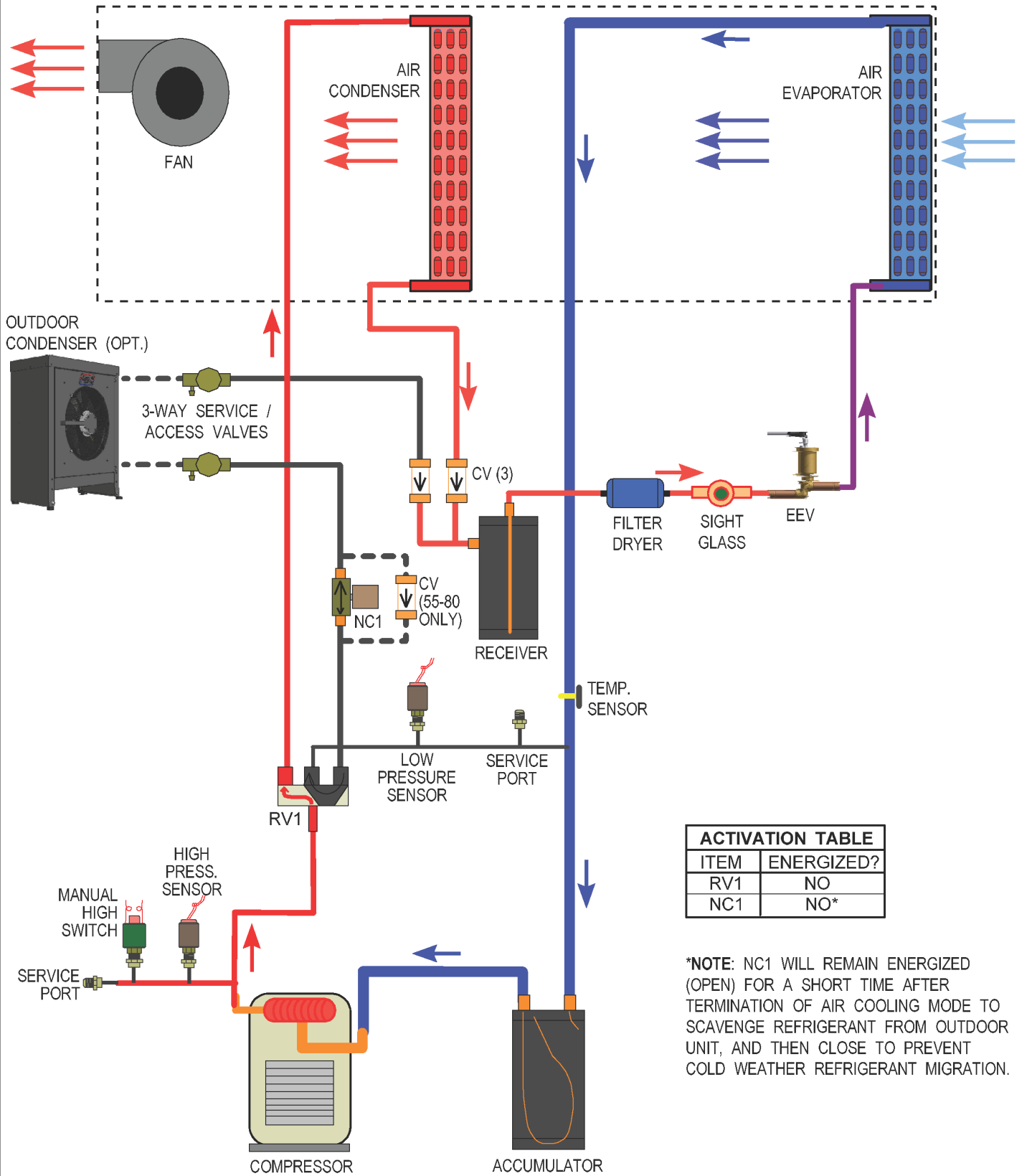

ACTIVATION TABLE	
ITEM	ENERGIZED?
RV1	NO
NC1	NO*

\*NOTE: NC1 WILL REMAIN ENERGIZED (OPEN) FOR A SHORT TIME AFTER TERMINATION OF AIR COOLING MODE TO SCAVENGE REFRIGERANT FROM OUTDOOR UNIT, AND THEN CLOSE TO PREVENT COLD WEATHER REFRIGERANT MIGRATION.

01	Initial Release	D. RHEAULT	D. RHEAULT	1-May-2024	Drawn By Dan Rheault	Date 1-May-2024	<b>MARITIME GEOTHERMAL LTD.</b> 170 Plantation Rd. Petitcodiac, NB E4Z 6H4
					Checked By Dan Rheault	Date 1-May-2024	
					Approved By Dan Rheault	Date 1-May-2024	
					Approved By (MFG)	Date	Drawing Name PC-***-X Refrigeration Circuit Diagram - Air Reheat Mode
REV	ECO #	IMPL BY	APVD BY	DATE	Approved By	Date	Size A
							Drawing Number <b>002698RCD</b>
							REV <b>01</b>
							SHEET 1 of 1

# PC-X Refrigeration Circuit - Heat Rejection Mode

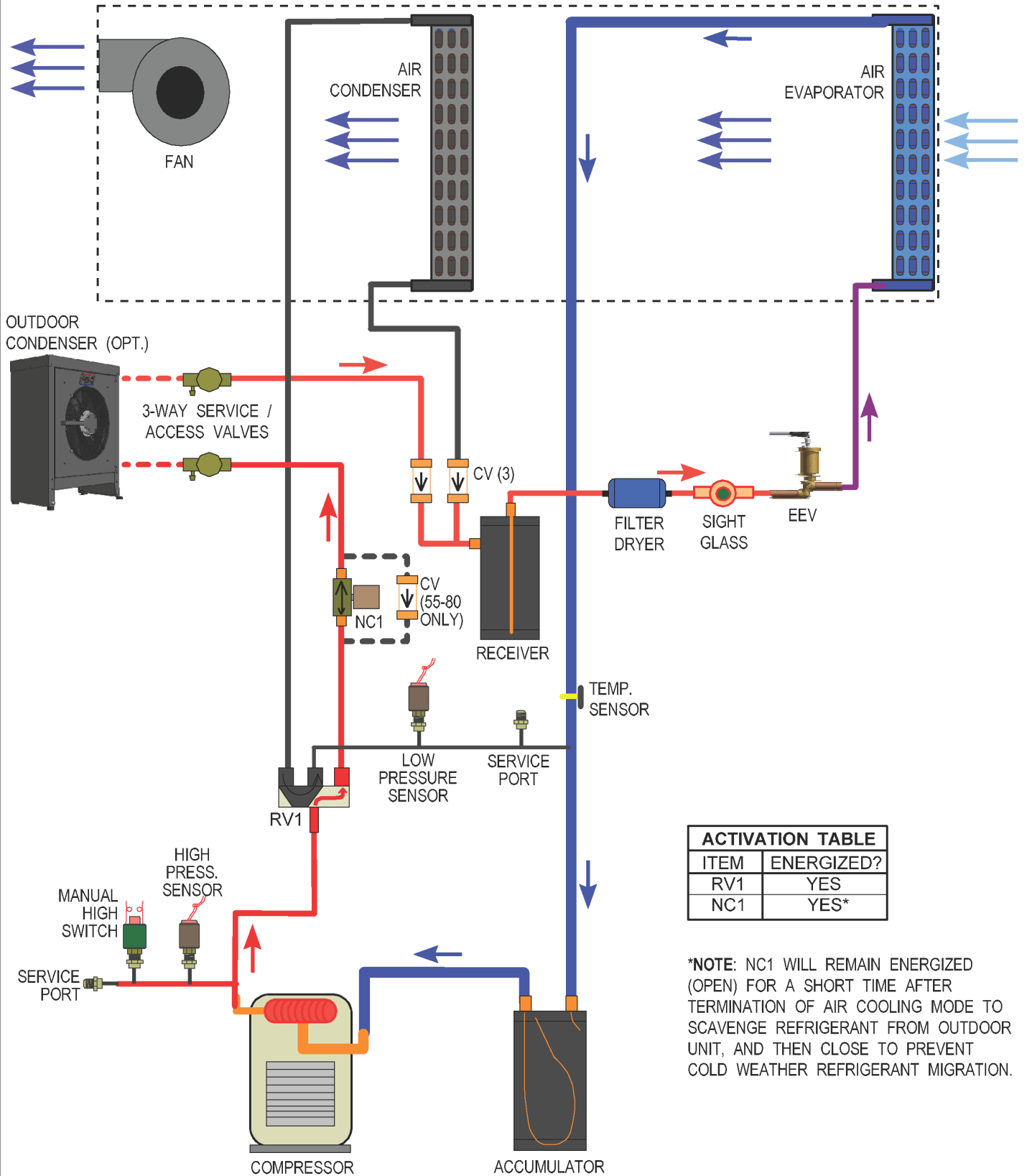

ACTIVATION TABLE	
ITEM	ENERGIZED?
RV1	YES
NC1	YES*

\*NOTE: NC1 WILL REMAIN ENERGIZED (OPEN) FOR A SHORT TIME AFTER TERMINATION OF AIR COOLING MODE TO SCAVENGE REFRIGERANT FROM OUTDOOR UNIT, AND THEN CLOSE TO PREVENT COLD WEATHER REFRIGERANT MIGRATION.

					Drawn By Dan Rheault	Date 1-May-2024	MARITIME GEOTHERMAL LTD. 170 Plantation Rd. Petitcodiac, NB E4Z 6H4
					Checked By Dan Rheault	Date 1-May-2024	
					Approved By Dan Rheault	(ENG) Date 1-May-2024	Drawing Name PC-***X Refrigeration Circuit Diagram - Heat Rejection Mode
					Approved By (MFG)	Date	Size A
01	Initial Release	D. RHEAULT	D. RHEAULT	1-May-2024	Approved By	Date	Drawing Number 002699RCD
REV	ECO #	IMPL BY	APVD BY	DATE			REV 01
							SHEET 1 of 1

# Engineering Guide Specifications

---

## General

The pool conditioner shall be a single package indoor unit, with optional outdoor condenser unit or geothermal ground loop heat exchanger for outdoor heat rejection provided as an accessory. The pool conditioner shall be capable of cooling and dehumidifying indoor air, and rejecting heat to the indoor air, pool water, or optional outdoor condenser, with user-adjustable heating priority setting. The pool conditioner shall be available without the pool water heat rejection coil for applications where pool heat is not required. The unit shall be listed by a nationally recognized safety-testing laboratory (NRTL) or agency, such as UL, CSA, TUV, or ETL. The package unit, as manufactured by Maritime Geothermal, Petitcodiac, New Brunswick, shall be designed to operate correctly within liquid temperature ranges specified on the "Control Temperature Limits" table in this engineering specification document.

## Factory Quality

Each unit shall be run tested at the factory with normal operating airflow and water circulating through the pool loop. Quality control system checks shall include: computerized nitrogen pressurized leak test, evacuation of refrigeration circuit to sustained vacuum, accurate system charge, detailed operating tests in pool water heat and air reheat modes, and quality cross check all operational and test conditions to pass/fail criteria. Units tested without air flow or without water flow are not acceptable. Units provided with optional outdoor condenser shall be run tested with outdoor condenser. The units shall be warranted by the manufacturer against defects in materials and workmanship in accordance with the warranty section at the end of this document. Optional extended factory warranty coverage may be available.

## Cabinet

Each unit shall be enclosed in a sheet metal cabinet. Cabinet shall be constructed of powder coated galvanized sheet metal of minimum 20 gauge. Sheet metal gauge shall be higher where structurally required. Design and construction of cabinet shall be such that it is rigid and passes the CSA/UL Loading Test requirements (200 lb roof test and 25 lb guard test). All panels shall be lined with minimum 1/2 inch [12.7 mm] thick acoustic type glass fiber insulation. All insulation shall meet the fire retardant provisions of NFPA 90A. This material shall also provide acoustical benefit. The unit must have a minimum of four access panels for serviceability of the compressor compartment. Units having only one access panel to compressor/heat exchangers/expansion device/refrigerant piping shall not be acceptable. The electrical box shall have separate holes and knockouts for entrance of line voltage and low voltage control wiring. All factory-installed wiring passing through factory knockouts and openings shall be protected from sheet metal edges at openings by plastic grommets.

## Refrigerant Circuit

All units shall contain only one sealed refrigerant circuit, containing a hermetic motor scroll compressor, two coated air coils, pool water coaxial heat exchanger, electronic expansion valve (EEV), 4-way reversing valves, high and low refrigerant pressure sensors, manual reset high pressure control, refrigerant service ports, liquid line filter-dryer, sight glass, refrigerant receiver, and suction accumulator.

Compressors shall be supplied with isolation consisting of rubber vibration isolators between the compressor and mounting plate, and rubber vibration isolators between the mounting plate and cabinet. Compressor motors shall have internal overload protection.

The water to refrigerant heat exchangers shall consist of a PVC outer jacket with twisted titanium inner tube, designed and certified for 600 psig [4136 kPa] working pressure on the refrigerant side and 75 psig [520 kPa] on the water side.

The refrigerant to air heat exchangers shall be of a multi-circuit design with copper tubing and aluminum fins with nozzle-style refrigerant distributor for evaporator service. They shall be designed and certified for 650 psig [4482kPa] working pressure on the refrigerant side, and shall be electro-coated ('e-coated' or 'i-coated') for corrosion protection.

The electronic expansion valve shall be of stepper-motor rather than pulsing type, and shall provide proper superheat control over the unit's operating range with minimal deviation from superheat setpoint. Superheat shall be determined through the suction pressure-temperature method. Externally mounted pressure controlled water regulating flow valves or thermostatic expansion valves (TXV's) in place of electronic expansion valves are not acceptable.

The suction accumulator shall be insulated with minimum 3/8" thick closed cell insulation to prevent condensation. The accumulator's internal oil return port shall be sized properly for the unit's operating range. To ensure proper oil return, suction accumulator shall not be 'oversized'.

## **Fan/Blower**

The blower shall be a squirrel cage type, constructed of corrosion resistant material, with unobstructed removable venturi to allow front-side-only servicing of fan motor. The air return shall be on the right when looking at the front of the unit. Top, side (left end), or down air discharge shall be provided as factory options. The fan motor shall be direct drive electrically commutated motor (ECM) with soft start, variable speed, and constant airflow functionality that maintains selected air flow up to a maximum external static of 0.5" WC.

## **Auxiliary Heat (Plenum Heater)**

A plenum heater shall be provided as standard to be field installed in the discharge ductwork outside the unit. Two stages of the plenum heater shall be controlled by two provided dry contacts in the PC unit.

## **Condensate Tray**

The condensate tray shall be made of stainless steel and be large enough to catch any condensation that drips from the evaporator air coil during operation. There shall be two condensate drain connections provided for redundancy, of type PVC 3/4" FNPT.

## **Piping and Connections**

The unit shall have one set of primary water in and out connections for pool water. The primary connection type shall be 2" nominal PVC union with socket connection. All water connectors shall be rigidly mounted to cabinet with corrosion resistant fasteners to prevent relative movement.

The indoor unit shall be provided charged with sufficient refrigerant for the installed system to operate properly with up to 20 ft of interconnecting line set to optional outdoor unit. The indoor unit shall be equipped with two 3-way refrigerant access valves for connection to the outdoor unit, so that refrigerant does not need to be removed from the system during installation.

## **Electrical**

Controls and safety devices shall be factory wired and mounted within the unit. Controls shall include 24 volt alternating current (24VAC) activated compressor contactor, and 24VAC 100VA transformer with built in circuit breaker or fused on both primary and secondary sides. A terminal strip with screw in terminals shall be provided for field control wiring. Units shall be name-plated for use with time delay fuses or circuit breakers. Unit controls shall be 24VAC and provide heating as required by the remote thermostat or controller, or on-board controller. Unit shall provide remote fault indication to the control system via serial communications as well as provide fault messages on the front panel LCD display.

## **Unit Control**

The control system shall have the following features:

1. Anti-short cycle time delay on compressor operation. Time delay shall be a minimum of 5 minutes, for both thermostat demand and safety control reset starts. An override shall be provided to disable this delay for unit commissioning and testing purposes.
2. Random compressor start delay of 0-120 seconds on unit powerup to facilitate starting multiple units after a power failure.
3. Compressor shutdown for high or low refrigerant pressures, Loss of Charge (LOC), optional low flow conditions, and for optional phase protection faults on three phase models.
4. Automatic intelligent reset: after a trip, unit shall automatically restart when short cycle delay expires if the fault has cleared. Should a fault reoccur 2 times sequentially then permanent lockout shall occur, requiring cycling of the power to the unit in order to reset.
5. Manual reset high pressure in case of electronic board failure.
6. The low pressure shall not be monitored for the first 90 seconds after a compressor start to prevent nuisance safety trips.
7. 2 x 16 backlit Liquid Crystal Display (LCD) and four buttons provide basic configuration and data access.
8. Universal Serial Bus (USB) port for full data access and diagnostic information, including manual override of all inputs and outputs, data-logging and real-time charting.
9. Dry contact input for overall air flow reduction according to a user-adjustable parameter, e.g. 15%.

A communicating air thermostat that measures room temperature and humidity and allows adjustment of air setpoints shall be included with the PC unit, along with suitable twisted-pair connection wire. The PC unit shall have an on-board function for control of pool water temperature without external sensor or aquastat. Dry contacts shall be present to control both auxiliary air and auxiliary pool water heat, as well as the pool pump.

Maritime Geothermal works continually to improve its products. As a result, the design and specifications of any product may be changed without notice. Please contact Maritime Geothermal at 1-506-756-8135 or visit [www.nordicghp.com](http://www.nordicghp.com) for latest design and specifications. Purchaser's approval of this data set signifies that the equipment is acceptable under the provisions of the job specification. Statements and other information contained herein are not express warranties and do not form the basis of any commercial contract or other agreement between any parties, but are merely Maritime Geothermal's statement of opinion regarding its products.

# LIMITED WARRANTY

MARITIME GEOTHERMAL LTD. warrants that its pool conditioners shall be free from defects in materials and workmanship for a period of ONE (1) YEAR after the date of installation or for a period of ONE (1) YEAR AND SIXTY (60) DAYS after the date of shipment, whichever occurs first. This warranty covers all internal components of the unit.

MARITIME GEOTHERMAL LTD. shall, at its option, repair or replace any part covered by this warranty. Defective parts shall be returned to MARITIME GEOTHERMAL LTD., transportation charges prepaid. Replacement of repaired parts and components are warranted only for the remaining portion of the original warranty period.

## This warranty is subject to the following conditions:

1. The geothermal heat pump(s) must be properly installed and maintained in accordance with MARITIME GEOTHERMAL LTD.'s guidelines. Improper installation **includes but is not limited to** the following conditions:
  - Loop flow lower than listed in engineering specification or as expressly approved by MARITIME GEOTHERMAL LTD.
  - Operating unit either manually or with automated controls so that the unit is forced to function outside its normal operating range or in a fashion which directly or indirectly leads to failure of components or the entire unit
  - Disabling of safety controls
  - Fouled heat exchangers due to poor water or air quality
  - Failure to use filters or strainers, or failure to clean them regularly
  - Impact or physical damage sustained by the heat pump
  - Poor refrigeration maintenance practices, including brazing without nitrogen flow, or using wrong braze/flux
  - Incorrect voltage or missing phase supplied to unit
  - Unit modified electrically or mechanically from factory supplied condition
  - Water quality outside of recommended limits (e.g. salinity or pH)
  - Corrosion damage due to corrosive ambient environment
  - Failure due to excessive cycling caused by improper mechanical setup or improperly programmed external controller
  - Physical loads or pressures placed on unit from external equipment
2. The installer must complete the **Startup Record** and return it to MARITIME GEOTHERMAL LTD. within 21 days of unit installation.
3. For new construction, it is the responsibility of the building or general contractor to supply temporary heat to the structure prior to occupancy. Pool conditioners are designed to dehumidify and provide heat only to the completely finished and insulated structure. Startup of the unit shall not be scheduled prior to completion of construction and final duct installation for validation of this warranty.
4. It is the customer's responsibility to supply the proper quantity and quality of water.

MARITIME GEOTHERMAL LTD.'s sole and exclusive liability shall be, at its option, to repair or replace any part or component which is returned by the customer during the applicable warranty period set forth above, provided that (1) MARITIME GEOTHERMAL LTD. is promptly notified in writing upon discovery by the customer that such part or component fails or is defective (2) the customer returns such part or component to MARITIME GEOTHERMAL LTD., transportation charges prepaid, within (30) thirty days of failure, and (3) MARITIME GEOTHERMAL LTD.'s examination of such component discloses to its satisfaction that such part or component has failed or is defective and was not caused by one of the circumstances listed above. MARITIME GEOTHERMAL LTD. will not be responsible for any consequential damages or labour costs incurred. In addition, MARITIME GEOTHERMAL LTD. will not be responsible for the cost of replacement parts purchased from a third party.