



# Engineering Specification / Submittal

## ATW-75-HACW-X-\*T-\*

Air to Water Heat Pump  
**R454b**, 60 Hz



Maritime Geothermal Ltd.  
P.O. Box 2555, 170 Plantation Road  
Petitcodiac, NB E4Z 6H4  
(506) 756-8135

info@nordicghp.com  
www.nordicghp.com  
003056SPC-01



# A2L refrigerant: mildly flammable.

Read *Application, Installation, and Service Manual* for precautions and procedures.



Installation of a unit with **A2L** refrigerant may require calculations involving the size of the mechanical room and/or rooms served by the unit. These calculations may affect installation procedures used and ventilation provided, and should be fully understood and considered to ensure code compliance.

## Model Nomenclature

### Indoor Unit:

**ATW - 75 - HACW - X - 1T - C - xx**

**Series:**

ATW = Air To Water

**Nominal Size:**

- 25 = 020 compressor
- 45 = 030 compressor
- 55 = 040 compressor
- 65 = 051 compressor
- 75 = 060 compressor

**Function:**

- H = Heating
- AC = Active Cooling
- W = domestic hot Water

**Refrigerant:**

**X** = R454b [A2L]

**Revision:**

01, 02, etc.

**Indoor Coil:**

- C = Copper coaxial
- Y = Cupro-Nickel coax & piping
- Z = Cupro-Nickel coax only

**Compressor:**

T = 2 stage scroll

**Voltage Code:**

- 1 = 208/230-1-60
- 2 = 208-3-60
- 4 = 460-3-60

APPLICATION/AVAILABILITY TABLE							
SERIES	SIZE	FUNCTION	REFRIGERANT	VOLTAGE	COMPRESSOR	INDOOR COIL	REVISIONS
ATW	75	HACW	<b>X</b>	1 2 4	T	C Y Z	01

### Matching Outdoor Unit:

**ACE - 75 - X - 1 - KDE - xx**

**Series:**

ACE = All weather Condenser / Evaporator

**Nominal Size:**

75 = matched to size 75 indoor unit

**Refrigerant:**

**X** = R454b [A2L]

**Revision:**

01, 02, etc.

**Fan:**

- D = Direct Drive
- E = EC motor

**Air Coil:**

- S = Standard
- K = Coated

**Voltage Code:**

1 = 208~277-1-60

Maritime Geothermal Ltd. has a continuous improvement policy and reserves the right to modify specification data at any time without prior notice .

# Features

- ⇒ **ATW Series** is a **split air source hydronic heat pump**, with compressor & hydronics & electronics completely indoors
- ⇒ System includes **ACE Series** outdoor evaporator/condenser unit
- ⇒ **R454b** refrigerant (GWP=466) is climate change-friendly. Note that R454b is an **A2L**.
- ⇒ **TUV listed** (CSA/UL/ETL equivalent)

## GEN2 Control

- Built in hydronic temperature control means no external sensor or aquastat required
- Outdoor reset functionality for better COP during warm weather
- Dry contacts for auxiliary heat, controlled by ATW
- Provision for powering indoor circulator
- Advanced control board with BACnet MS/TP interface for remote control and data access including all sensor data & alarm conditions
- LCD display/user interface
- USB port for complete data access; free PC App software for Windows included

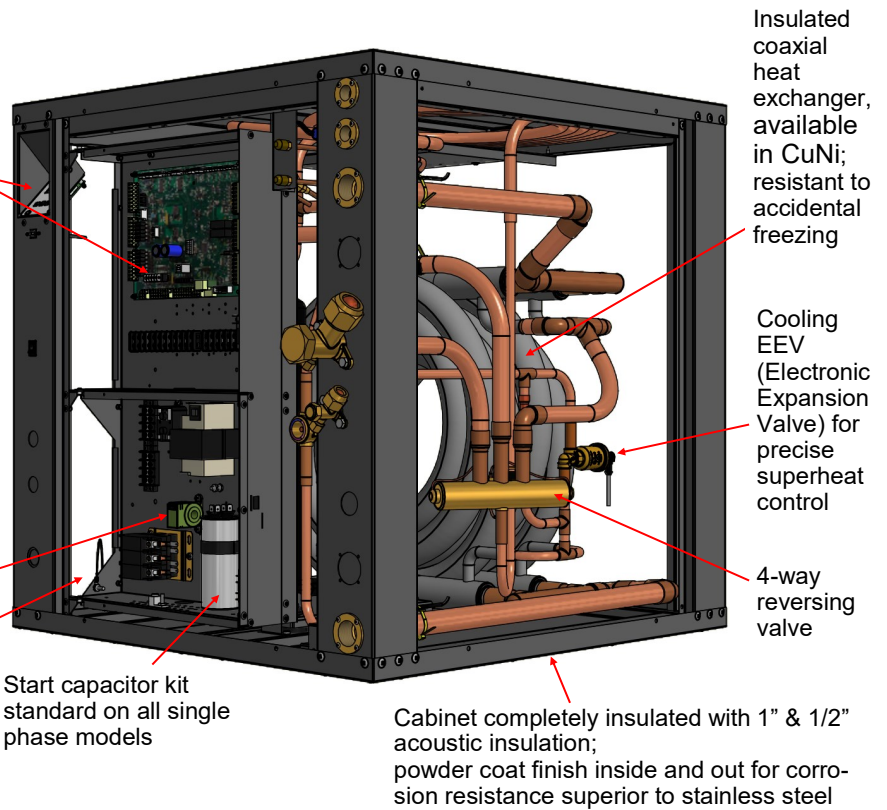

Current sensor

Access panels for all four sides; serviceable from two sides

Start capacitor kit standard on all single phase models

Swing out electrical box for unobstructed front access to compressor

High & low refrigerant access ports

Double wall desuperheater for domestic hot water heating, with 1/2" FPT brass connections and built-in circulator

1" FPT brass fittings for indoor loop connections

Temperature sensors on both water lines and refrigerant suction line

High and low refrigerant pressure sensors

Easy refrigerant connection between indoor and outdoor units using 3-way access valves, like a mini split

Sight glass

Bi-flow filter-dryer

Suction accumulator

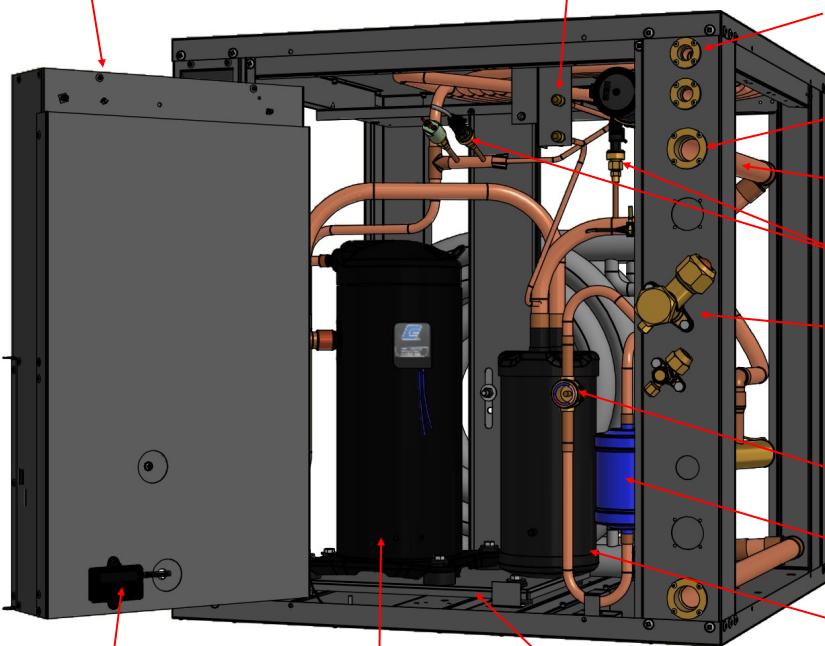

A2L refrigerant leak detector

Copeland two-stage scroll compressor

Dual grommet mounting plate system for compressor for reduced noise and vibration

# Features - Outdoor Unit

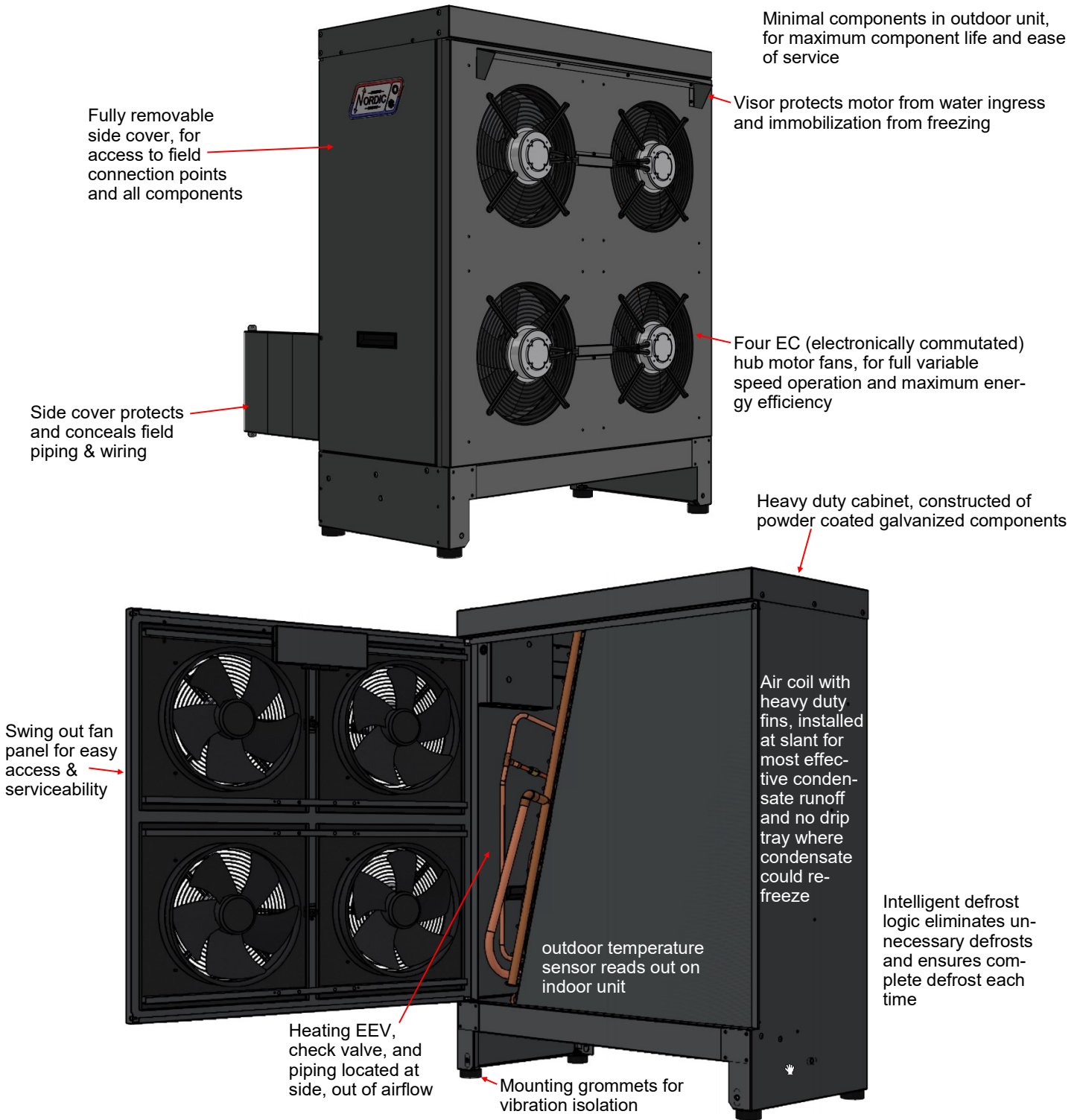

## Available Accessories

- Hydronic buffer tank with 12, 15, or 20kW of electric backup elements
- Barbed P/T port adapters for indoor loop connections
- Anti-vibration pad for under unit
- Compressor sound jacket
- Secure Start module
- CuNi hydronic heat exchanger

# Dimensions

All dimensions in inches

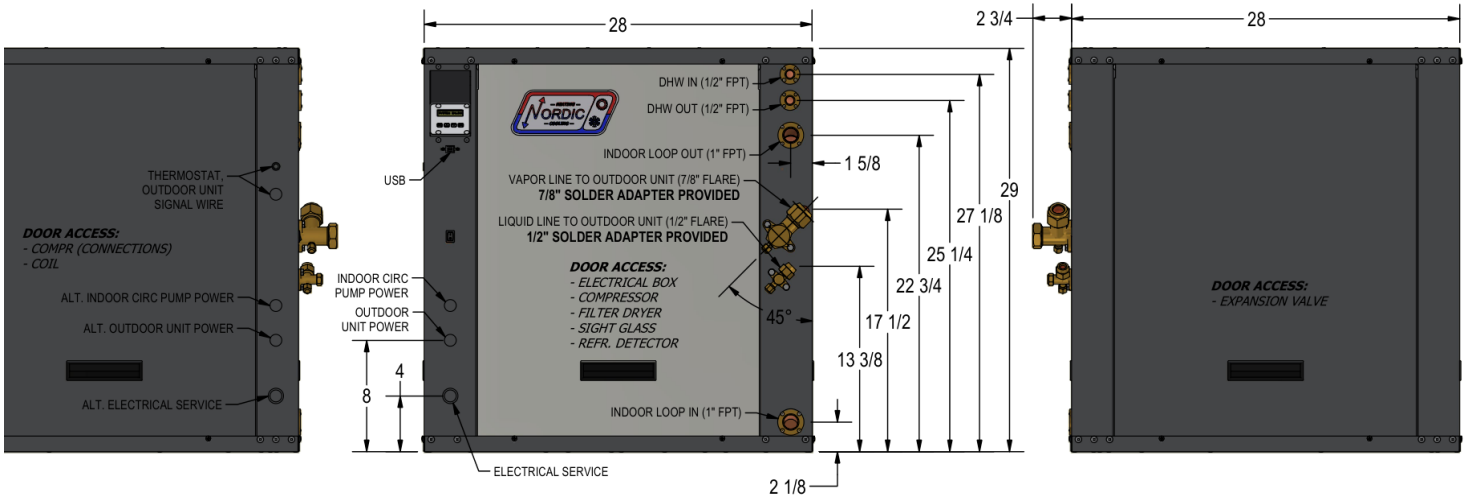

LEFT SIDE  
CLEARANCE  
OPTIONAL

RECOMMENDED  
FRONT CLEARANCE:  
**3 FT**

RECOMMENDED  
RIGHT SIDE CLEARANCE:  
**2 FT**

NO BACK CLEARANCE REQUIRED

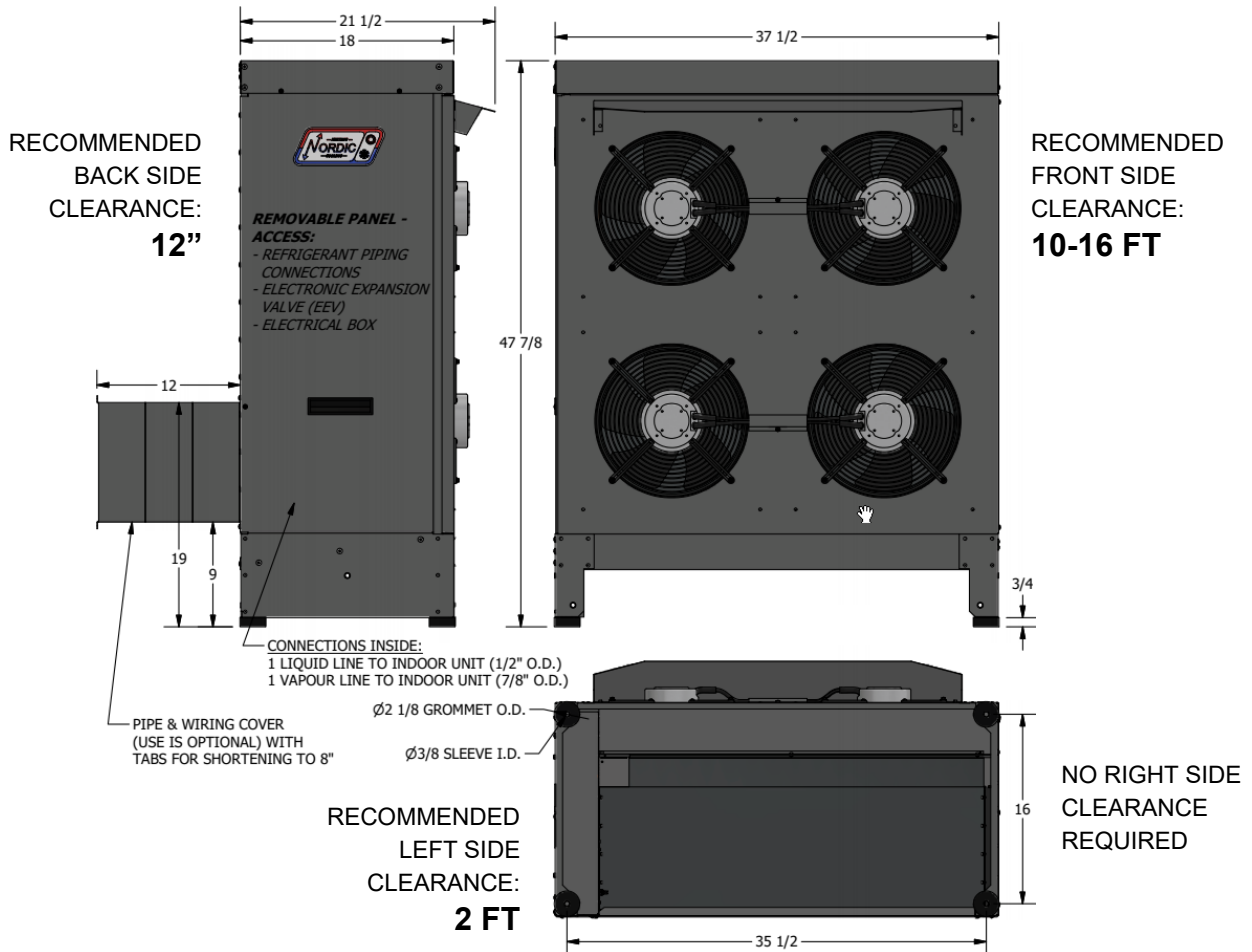

# Dimensions

## WITH LEG KIT

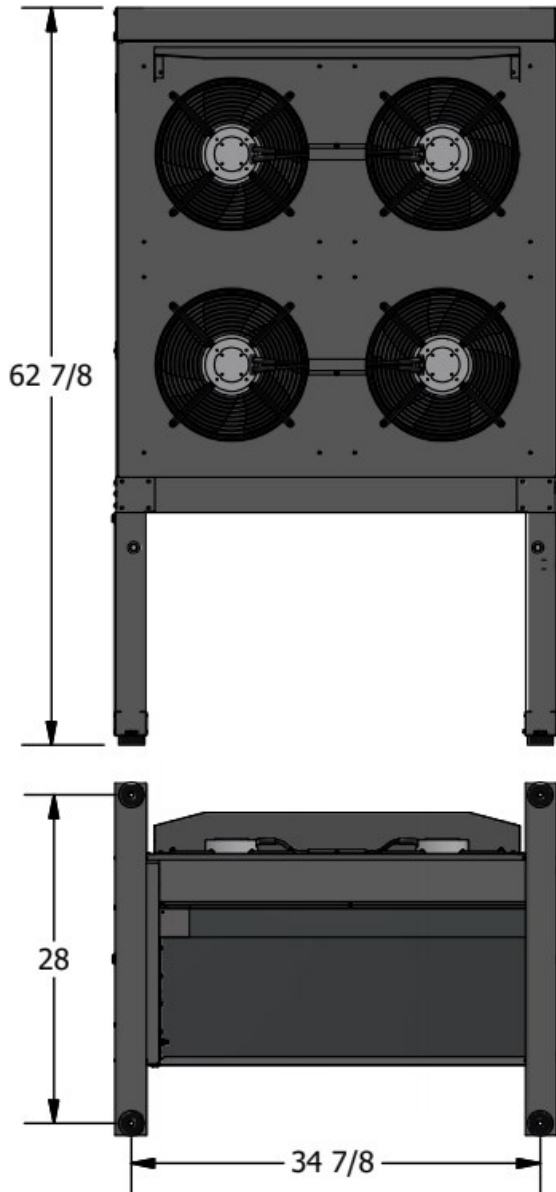

*All dimensions in inches*

## WITH TALL LEG KIT

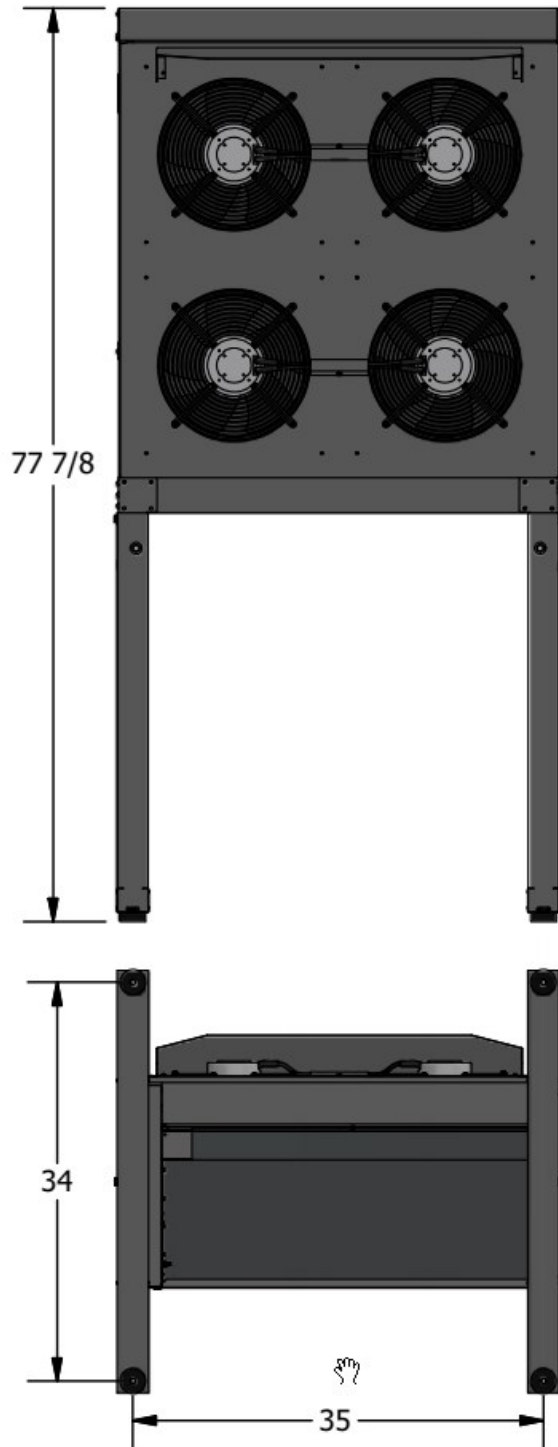

# Specifications

Electrical Specifications (R454b)											
Code	Power Supply			Compressor		Indoor Circulator	Outdoor Unit	FLA	MCA	Maximum Fuse/Breaker	Minimum Wire Size
	V-ø-Hz	MIN	MAX	RLA	LRA	Max A	Max A	Amps	Amps	Amps	ga
1	208/230-1-60	187	253	28.0	166	4.0	3.0	35.8	42.8	60	#6-2*
2	208-3-60	187	229	19.2	162	4.0	3.0	27.0	31.8	50	#8-3*
4	460-3-60	414	506	9.1	71	4.0	3.0	16.9	19.2	30	#10-4

\*one additional conductor required if connecting 115VAC circulators to unit.

Shipping Information				
ITEM	WEIGHT lb. (kg)	DIMENSIONS in (cm)		
		L	W	H
ATW-75 Indoor Unit	362 (164)	34 (86)	34 (86)	35 (89)
ACE-75 Outdoor Unit	295 (134)	36 (91)	70 (178)	56 (142)

Refrigerant Charge (Per Circuit)				
MODEL	TYPE	lb	kg	Oil Type
ATW-75	10.0	4.5	R454b	POE

 **A2L**

- Note that R454b charge per refrigeration circuit is greater than 'm1' but less than 'm2' as defined in the UL/CSA 60335-2-40 standard
- Refrigerant charge is subject to slight revision but always below m2; actual charge is indicated on the unit nameplate
- Oil capacity is marked on the compressor label

Indoor Unit Sound Levels (dBA)*		
MODEL	1 ft distance	3 ft distance
ATW-75	55.7	53.0

\* With all doors installed.

Outdoor Unit Sound Levels (dBA)*								
MODEL	1 ft distance		3 ft distance		5 ft distance		10 ft distance	
	Front	Side	Front	Sides	Front	Sides	Front	Sides
ATW-75	71.7	66.8	68.7	63.7	65.7	61.2	60.0	57.1

\* At maximum fan speed. This occurs in heating mode, or in cooling mode with outdoor greater than ~27°C.

Operating Temperature Limits					
Loop	Mode	Parameter	(°F)	(°C)	Note
Indoor	Heating	Minimum ELT	60	15	Reduce flow if necessary during startup.
	Heating	Maximum LLT	120	49	
	Cooling	Minimum LLT	41	5	Water system (no antifreeze).
	Cooling	Minimum LLT	32	0	Antifreeze system. Adequate freeze protection required.
	Cooling	Maximum ELT	80	27	
Outdoor	Heating	Minimum EAT	-7	-22	ACE Outdoor Unit automatically stops compressor below this temp.
	Cooling	Maximum EAT	120	49	ACE Outdoor Unit automatically stops compressor above this temp.

\* Values in this table are for rated liquid flow values.

**Loop Pressure Drop Data**

			Water 104°F		Water 50°F		15% Methanol 32°F		35% prop. glycol 32°F	
			gpm	L/s	psi	kPa	psi	kPa	psi	kPa
<b>ATW-75</b>	6	0.38	0.6	4.1	0.7	4.8	0.9	6.2	1.2	8.2
	7	0.44	0.8	5.5	0.9	6.2	1.0	6.9	1.3	9.0
	8	0.50	1.2	8.3	1.3	9.0	1.3	9.0	1.7	12
	9	0.57	1.5	10	1.6	11	1.6	11	2.1	14
	10	0.63	1.8	12	1.9	13	2.1	14	2.8	19
	11	0.69	2.1	14	2.3	16	2.4	17	3.2	22
	12	0.76	2.4	17	2.6	18	2.9	20	3.8	26
	13	0.82	2.8	19	3.0	21	3.3	23	4.3	30
	14	0.88	2.9	20	3.2	22	3.7	26	4.9	33
	15	0.95	3.2	22	3.5	24	4.1	28	5.4	37
	<b>16</b>	<b>1.01</b>	<b>3.8</b>	<b>26</b>	<b>4.0</b>	<b>28</b>	<b>4.7</b>	<b>32</b>	<b>6.2</b>	<b>43</b>
	17	1.07	4.2	29	4.4	30	5.2	36	6.8	47

## Standard Capacity Ratings

The tables show the heat pump performance at the standard rating conditions specified in *AHRI standard 550/590 with Addendum 1, September 2017*. There is currently no AHRI certification program for air to water heat pumps; therefore, the blue **AHRI CERTIFIED** mark is not applicable to any manufacturer's air to water heat pumps.

All data is for **60 Hz operation** with **water** as the indoor loop fluid.

METRIC

Standard Capacity Ratings: <b>HEATING</b>							
Model	Loop Flow (gpm)	ΔP (psi)	LLT	Outdoor Air Temp	Input Energy (W)	Capacity (Btu/hr)	COP <sub>H</sub>
ATW-75	16.0	3.8	105°F	47°F	4,048	59,400	4.30
				17°F	4,767	39,200	2.41
			120°F	47°F	4,851	57,100	3.45
				17°F	5,586	38,500	2.02

Standard Capacity Ratings: <b>HEATING (METRIC)</b>							
Model	Loop Flow (L/s)	ΔP (kPa)	LLT	Outdoor Air Temp	Input Energy (W)	Capacity (W)	COP <sub>H</sub>
ATW-75	1.0	26	41°C	8°C	4,048	17.4	4.30
				-8°C	4,767	11.5	2.41
			49°C	8°C	4,851	16.7	3.45
				-8°C	5,586	11.3	2.02

Standard Capacity Ratings: <b>COOLING</b>							
Model	Loop Flow (gpm)	ΔP (psi)	ELT	Outdoor Air Temp	Input Energy (W)	Capacity (Btu/hr)	EER COP <sub>c</sub>
ATW-75	16.0	4.0	54°F	95°F	4,758	47,100	9.9 2.90

Standard Capacity Ratings: <b>COOLING (METRIC)</b>							
Model	Loop Flow (gpm)	ΔP (psi)	ELT	Outdoor Air Temp	Input Energy (W)	Capacity (W)	EER COP <sub>c</sub>
ATW-75	1.0	28	12°C	35°C	4,758	13.8	9.9 2.90

# Performance Tables **ATW-75-HACW-X-1T** R454b, 60 Hz, YAS60K1E-PFV

HEATING	OUTDOOR			ELECTRICAL		INDOOR						
	Outdoor Air Temperature	Evaporating Temp. (°F)	Heat Absorbed (Btu/hr)	Compressor Current (A)	Input Power (W)	ELT	Condensing Temp. (°F)	Liquid Flow (gpm)	LLT	Delta T (°F)	Heating (Btu/hr)	COP <sub>H</sub>
	-5°F	-16	12,800	22.8	5,305	101	110	16	105°F	3.7	29,600	1.64
	5°F	-8	17,600	21.8	5,059	101	110			4.2	33,600	1.95
	15°F	1	23,000	20.7	4,817	100	109			4.8	38,100	2.32
	25°F	9	29,400	19.6	4,573	100	109			5.5	43,700	2.80
	35°F	17	36,600	18.5	4,335	99	109			6.3	50,100	3.39
	45°F	26	45,000	17.4	4,098	98	108			7.3	57,700	4.13
	55°F	34	54,700	16.3	3,856	97	108			8.4	66,600	5.06
	65°F	43	65,800	15.1	3,618	95	108			9.7	76,800	6.22
-5°F	-	-	-	-	-	-	16	120°F	LLT is limited to 105°F at these outdoor temperatures			
5°F	-	-	-	-	-	-			4.7	37,500	1.95	
15°F	2	19,600	24.2	5,635	115	124			5.4	42,600	2.31	
25°F	11	25,500	23.2	5,394	115	124			6.1	48,500	2.76	
35°F	19	32,200	22.1	5,152	114	123			7.0	55,500	3.32	
45°F	28	40,100	21.0	4,903	113	123			8.1	63,800	4.03	
55°F	36	49,300	19.8	4,643	112	123			9.3	73,600	4.92	
65°F	45	59,900	18.6	4,381	111	122						

COOLING	Outdoor Air Temperature	Condensing Temp. (°F)	Heat Rejected (Btu/hr)	Compressor Current (A)	Input Power (W)	ELT	Evaporating Temp. (°F)	Liquid Flow (gpm)	LLT	Delta T (°F)	Cooling (Btu/hr)	EER	COP <sub>c</sub>
	50°F	62	69,300	12.8	2,730	54°F	39	16	47	-7.5	60,000	22.0	6.45
	60°F	72	68,100	13.4	3,046		39		47	-7.2	57,700	18.9	5.54
	70°F	83	66,800	14.7	3,428		40		47	-6.9	55,100	16.1	4.72
	80°F	93	65,400	16.6	3,890		40		48	-6.5	52,100	13.4	3.93
	90°F	104	64,000	19.0	4,444		40		48	-6.1	48,800	11.0	3.22
	100°F	114	62,700	22.0	5,105		40		48	-5.6	45,300	8.9	2.61
	110°F	125	61,900	25.5	5,889		40		49	-5.2	41,800	7.1	2.08
	120°F	135	61,300	29.5	6,810		41		49	-4.8	38,100	5.6	1.64

METRIC

HEATING (METRIC)	OUTDOOR			ELECTRICAL		INDOOR						
	Outdoor Air Temperature	Evaporating Temp. (°C)	Heat Absorbed (kW)	Compressor Current (A)	Input Power (W)	ELT	Condensing Temp. (°C)	Liquid Flow (L/s)	LLT	Delta T (°C)	Heating (kW)	COP <sub>H</sub>
	-21°C	-26.8	3.8	22.8	5,305	38.5	43.3	1.0	40.5°C	2.1	8.7	1.64
	-15°C	-22.1	5.2	21.8	5,059	38.2	43.2			2.3	9.9	1.95
	-9°C	-17.4	6.7	20.7	4,817	37.9	43.0			2.7	11.2	2.32
	-4°C	-12.8	8.6	19.6	4,573	37.5	42.8			3.1	12.8	2.80
	2°C	-8.1	10.7	18.5	4,335	37.1	42.6			3.5	14.7	3.39
	7°C	-3.4	13.2	17.4	4,098	36.5	42.4			4.1	16.9	4.13
	13°C	1.2	16.0	16.3	3,856	35.9	42.2			4.7	19.5	5.06
	18°C	5.9	19.3	15.1	3,618	35.2	42.1			5.4	22.5	6.22
-21°C	-	-	-	-	-	-	1.0	49°C	LLT is limited to 40.5°C at these outdoor temperatures			
-15°C	-	-	-	-	-	-			2.6	11.0	1.95	
-9°C	-16.7	5.7	24.2	5,635	46.3	51.1			3.0	12.5	2.31	
-4°C	-11.9	7.5	23.2	5,394	45.9	50.8			3.4	14.2	2.76	
2°C	-7.2	9.4	22.1	5,152	45.5	50.7			3.9	16.3	3.32	
7°C	-2.5	11.8	21.0	4,903	45.0	50.5			4.5	18.7	4.03	
13°C	2.2	14.4	19.8	4,643	44.4	50.3			5.2	21.6	4.92	
18°C	6.9	17.6	18.6	4,381	43.7	50.1						

COOLING (METRIC)	Outdoor Air Temperature	Condensing Temp. (°C)	Heat Rejected (W)	Compressor Current (A)	Input Power (W)	ELT	Evaporating Temp. (°C)	Liquid Flow (L/s)	LLT	Delta T (°C)	Cooling (W)	EER	COP <sub>c</sub>
	10°C	17	20.3	12.8	2,730	12°C	4.0	1.0	8.0	-4.2	17.6	22.0	6.45
	16°C	22	20.0	13.4	3,046		4.1		8.2	-4.0	16.9	18.9	5.54
	21°C	28	19.6	14.7	3,428		4.2		8.4	-3.8	16.1	16.1	4.72
	27°C	34	19.2	16.6	3,890		4.3		8.6	-3.6	15.3	13.4	3.93
	32°C	40	18.8	19.0	4,444		4.4		8.8	-3.4	14.3	11.0	3.22
	38°C	46	18.4	22.0	5,105		4.6		9.1	-3.1	13.3	8.9	2.61
	43°C	52	18.1	25.5	5,889		4.7		9.3	-2.9	12.3	7.1	2.08
	49°C	57	18.0	29.5	6,810		4.8		9.5	-2.7	11.2	5.6	1.64

# BACnet Interface

The BACnet interface is an **MS/TP** connection via RS-485 twisted pair. BACnet **IP** is not available. Recommended wire: 22-24 AWG single twisted pair, 100-120 Ohms impedance, 17pF/ft or lower capacitance, with braided or aluminum foil shield, such as Belden 9841 or 89841.

The connector on the control board is a three wire removable screw connector. The signals are as follows:

- A: Communications line (+) (right pin)
- B: Communications line (-) (middle pin)
- C: Ground connection (left pin)

If connecting multiple units to one RS-485 connection point, connect the signal cable from the master building controller to the first unit. Connect the second unit to the first unit (in same connector), connect the third unit to the second unit, and so on until all units are connected (daisy-chain). Remove the TERM jumper (located just above the BACnet connector on control board) from all units except the last one. The shield ground should be connected only to the GND pin of the unit for single unit installations. For multiple units, the shield ground should only be connected to the GND pin of the last unit. The shield grounds for intermediate units should be connected together. The shield ground should be left unconnected at the building controller end for all cases.

Vendor: Maritime Geothermal Ltd.  
Vendor ID: 260  
Model Name: MGT GEN2 Control Board

The following parameters can be set via the PC App's *Configuration Window*:

- 1) **Baud rate**  
9600, 19200, 38400, or 76800
- 2) **MAC address**  
Maximum value is 125.
- 3) **Instance number**  
Maximum value is 4194303.

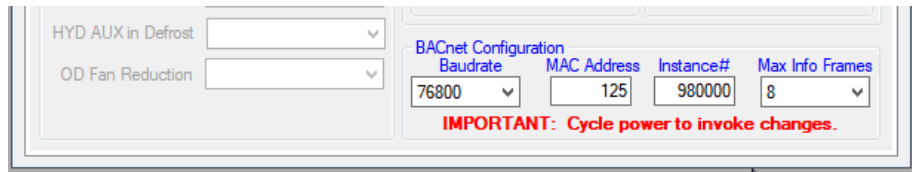

The BACnet parameter **Max\_Master** has a fixed value of **127** in this device.

BACnet data is available regardless of the selected control method. In order to control the unit via the BACnet interface, set **Control Source** to **BACnet** either by using the PC App's configuration window or the LCD menus.

**Refer to *Application, Installation, & Service Manual* for BACnet objects (read and write).**

# Engineering Guide Specifications

---

## General

The split air source hydronic heat pump shall consist of an indoor unit, containing the compressor and all electronics, and an outdoor unit containing only an air coil, fan, and expansion valve. The unit shall be capable of heating or cooling the indoor hydronic loop, for space heating or air conditioning purposes. The unit shall be listed by a nationally recognized safety-testing laboratory (NRTL), such as ETL, TUV, UL or CSA. The unit shall be rated in accordance with applicable standards of the Air Conditioning, Heating, and Refrigeration Institute / International Standards Organization (AHRI/ISO) and/or Canadian Standards Association (CSA). The heat pump, as manufactured by Maritime Geothermal, Petitcodiac, New Brunswick, shall be designed to operate correctly within the air and liquid temperature ranges specified on the "Operating Temperature Limits" table in this engineering specification document.

## Factory Quality

Each unit shall be run tested at the factory with water circulating in indoor loop and outdoor unit connected. Quality control system checks shall include: computerized nitrogen pressurized leak test, evacuation of refrigeration circuit to sustained vacuum, accurate system charge, detailed heating and cooling mode tests, and quality cross check all operational and test conditions to pass/fail criteria. Units tested without water flow are not acceptable. The units shall be warranted by the manufacturer against defects in materials and workmanship in accordance with the warranty section at the end of this document. Optional extended factory warranty coverage may be available.

## Cabinet

Each unit shall be enclosed in a sheet metal cabinet. Cabinet shall be constructed of powder coated galvanized sheet metal of minimum 20 gauge. Sheet metal gauge shall be higher where structurally required. Design and construction of cabinet shall be such that it is rigid and passes the CSA/UL Loading Test requirements (200 lb roof test). All panels shall be lined with minimum 1/2 inch [12.7 mm] thick acoustic type glass fiber insulation. All insulation shall meet the fire retardant provisions of NFPA 90A. This material shall also provide acoustical benefit. The indoor unit must have a minimum of four access panels for serviceability of the compressor compartment. Units having only one access panel to compressor/heat exchangers/expansion device/refrigerant piping shall not be acceptable. The electrical box shall have separate holes and knockouts for entrance of line voltage and low voltage control wiring. All factory-installed wiring passing through factory knockouts and openings shall be protected from sheet metal edges at openings by plastic grommets.

## Refrigerant Circuit

All units shall contain only one refrigerant circuit, containing a hermetic motor scroll compressor, Electronic Expansion Valves (EEVs), coaxial heat exchanger, factory installed high and low pressure sensors, manual reset high pressure switch, service ports, liquid line filter-dryer, sight glass, and suction accumulator.

Refrigerant used shall have a global warming potential (GWP) of less than 500. A refrigerant leak detector shall be factory installed.

Compressors shall be supplied with isolation consisting of rubber vibration isolators between the compressor and mounting plate, and rubber vibration isolators between the mounting plate and cabinet. Compressor motors shall have internal overload protection.

The water to refrigerant heat exchanger shall consist of a steel outer jacket with twisted copper inner tube, designed and certified for 600 psig [4136 kPa] working pressure on the refrigerant side and 450 psig [3108 kPa] on the water side. Heat exchangers headered together in parallel shall use a reverse-return or symmetrical arrangement on the water side and symmetrical arrangement on the refrigerant side to ensure even flow splitting. Heat exchangers shall be insulated over all of their outside surface with minimum 3/8" thick closed cell insulation. Insulation consisting of 1/8" closed-cell insulating tape shall not be acceptable.

The outdoor refrigerant to air heat exchanger shall be of a multi-circuit design with copper tubing and aluminum fins with nozzle-style refrigerant distributor for evaporator service. They shall be designed and certified for 650 psig [4482kPa] working pressure on the refrigerant side, and shall be electro-coated ('e-coated' or 'i-coated') for corrosion protection.

The electronic expansion valves shall be of stepper-motor rather than pulsing type, and shall provide proper superheat control over the unit's operating range with minimal deviation from superheat setpoint. Superheat shall be determined through the suction pressure-temperature method. Externally mounted pressure controlled water regulating flow valves or thermostatic expansion valves (TXV's) in place of electronic expansion valves are not acceptable.

The suction accumulator shall be insulated with minimum 3/8" thick closed cell insulation to prevent condensation. The accumulator's internal oil return port shall be sized properly for the unit's operating range. To ensure proper oil return, suction accumulator shall not be 'oversized'.

The unit shall be equipped with a double wall desuperheating heat exchanger, to heat domestic hot water with a small percentage of the unit's capacity while operating in space heating or cooling modes. A bronze head ECM circ pump and a temperature control to turn it off at 140°F / 60°C shall be built in.

## **Piping and Connections**

The indoor unit shall have one set of primary water in and water out connections. The primary connection type shall be 1" nominal female National Pipe Thread (NPT). All water connectors shall be rigidly mounted to cabinet with corrosion resistant fasteners to prevent relative movement. All water connectors shall be constructed of copper or brass material for corrosion resistance.

All internal water and refrigerant piping shall be insulated with minimum 3/8" thick closed cell insulation. Insulation consisting of 1/8" closed-cell insulating tape shall not be acceptable.

Desuperheater connections for domestic hot water shall be 1/2" NPT, rigidly mounted to cabinet with corrosion resistant fasteners to prevent relative movement. All water connectors shall be constructed of copper or brass material for corrosion resistance and potable water safety.

The indoor unit shall be provided charged with sufficient refrigerant for the installed system to operate properly with up to 20 ft of interconnecting line set. The indoor unit shall be equipped with two 3-way refrigerant access valves for connection to the outdoor unit, so that refrigerant does not need to be removed from the system during installation.

## **Electrical**

Controls and safety devices shall be factory wired and mounted within the unit. Controls shall include 24 volt alternating current (24VAC) activated compressor contactor, and 24VAC 100VA transformer with built in circuit breaker or fused on both primary and secondary sides. A terminal strip with screw in terminals shall be provided for field control wiring. Units shall be name-plated for use with time delay fuses or circuit breakers. Unit controls shall be 24VAC and provide heating as required by the remote thermostat or controller, or on-board controller. Unit shall provide remote fault indication to the control system via serial communications as well as provide fault messages on the front panel LCD display.

## **Unit Control**

The control system shall have the following features:

1. A Setpoint Control routine to control buffer tank temperature, including an indoor loop circulator control algorithm that allows operation without an external water temperature sensor or aquastat.
2. Anti-short cycle time delay on compressor operation. Time delay shall be a minimum of 5 minutes, for both thermostat demand and safety control reset starts. An override shall be provided to disable this delay for unit commissioning and testing purposes.
3. Random compressor start delay of 0-120 seconds on unit power up to facilitate starting multiple units after a power failure.
4. Compressor shutdown for high or low refrigerant pressures, Loss of Charge (LOC), optional low flow conditions, and for optional phase protection faults on three phase models.
5. Automatic intelligent reset: after a trip, unit shall automatically restart when short cycle delay expires if the fault has cleared. Should a fault reoccur 2 times sequentially then permanent lockout shall occur, requiring cycling of the power to the unit in order to reset.
6. Manual reset high pressure in case of electronic board failure.
7. The low pressure shall not be monitored for the first 90 seconds after a compressor start to prevent nuisance safety trips.
8. 2 x 16 backlit Liquid Crystal Display (LCD) and four buttons provide basic configuration and data access . Unit may be configured for stand alone operation.
9. Externally mounted Universal Serial Bus (USB) port for full data access and diagnostic information, including manual override of all inputs and outputs, data-logging and real-time charting.
10. BACnet connectivity for control by building automation system, and providing alarm feedback.
11. Automatic data logging with onboard data storage, retrievable through PC software application.

Maritime Geothermal works continually to improve its products. As a result, the design and specifications of any product may be changed without notice. Please contact Maritime Geothermal at 1-506-756-8135 or visit [www.nordicghp.com](http://www.nordicghp.com) for latest design and specifications. Purchaser's approval of this data set signifies that the equipment is acceptable under the provisions of the job specification. Statements and other information contained herein are not express warranties and do not form the basis of any commercial contract or other agreement between any parties, but are merely Maritime Geothermal's statement of opinion regarding its products.

# LIMITED RESIDENTIAL WARRANTY

MARITIME GEOTHERMAL LTD. warrants that the heat pumps manufactured by it shall be free from defects in materials and workmanship for a period of (5) FIVE YEARS after the date of installation or for a period of (5) FIVE YEARS AND (60) SIXTY DAYS after the date of shipment, whichever occurs first. In addition MARITIME GEOTHERMAL LTD. warrants that the compressor shall be free of defects in materials and workmanship for an additional period of (2) TWO YEARS from said date.

MARITIME GEOTHERMAL LTD. shall, at its option repair or replace any part or parts covered by this warranty which shall be returned to MARITIME GEOTHERMAL LTD., transportation charges prepaid, which, upon examination proves to be defective in materials or workmanship. Replacement or repaired parts and components are warranted only for the remaining portion of the original warranty period.

This warranty is subject to the following conditions:

1. The NORDIC® heat pump must be properly installed and maintained in accordance with MARITIME GEOTHERMAL LTD.'s installation and maintenance instructions.
2. The installer must complete the “**Installation Data Sheet**”, have it endorsed by the owner and return it to Maritime Geothermal Ltd. within 21 days of installation of the unit.
3. It is the responsibility of the building or general contractor to supply temporary heat to the structure prior to occupancy. These heat pumps are designed to provide heat only to the completely finished and insulated structure. Start-up of the unit shall not be scheduled prior to completion of construction and final duct installation for validation of this warranty.
4. It is the customer's responsibility to supply the proper quantity and quality of water.

If the heat pump, manufactured by MARITIME GEOTHERMAL LTD., fails to conform to this warranty, MARITIME GEOTHERMAL LTD.'s sole and exclusive liability shall be, at its option, to repair or replace any part or component which is returned by the customer during the applicable warranty period set forth above, provided that (1) MARITIME GEOTHERMAL LTD. is promptly notified in writing upon discovery by the customer that such part or component fails to conform to this warranty. (2) The customer returns such part or component to MARITIME GEOTHERMAL LTD., transportation charges prepaid, within (30) thirty days of failure, and (3) MARITIME GEOTHERMAL LTD.'s examination of such component shall disclose to its satisfaction that such part or component fails to meet this warranty and the alleged defects were not caused by accident, misuse, neglect, alteration, improper installation, repair or improper testing.