

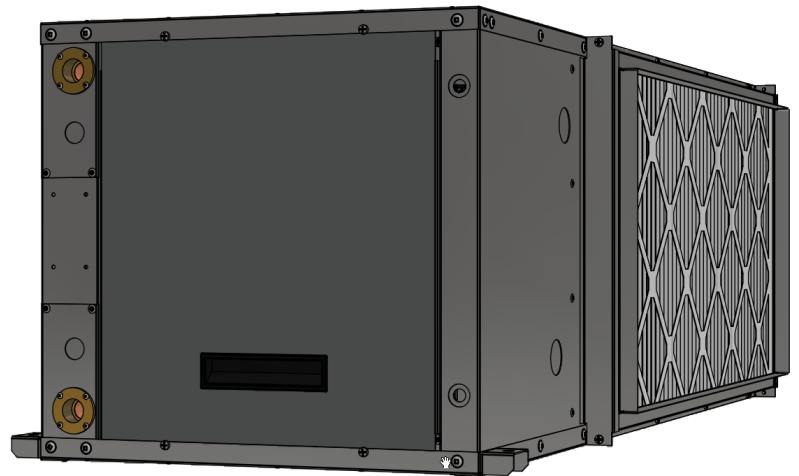

Engineering Specification / Submittal

RH-24-HAC-X-*L*-*SDE*F Horizontal Liquid to Air Heat Pump **R454b, 60 Hz**

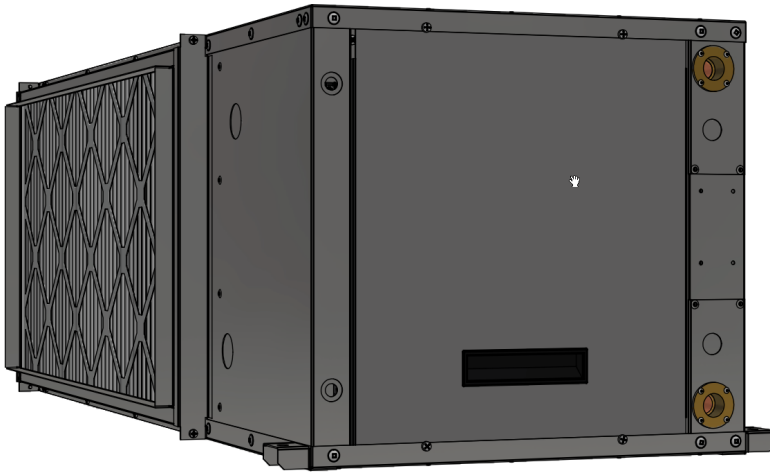

Maritime Geothermal Ltd.
P.O. Box 2555, 170 Plantation Road
Petitcodiac, NB E4Z 6H4
(506) 756-8135



info@nordicghp.com
www.nordicghp.com
003040SPC-01



A2L refrigerant: mildly flammable.

Read *Application, Installation, and Service Manual* for precautions and procedures.



Installation of a unit with **A2L** refrigerant may require calculations involving the size of the mechanical room and/or rooms served by the unit. These calculations may affect installation procedures used and ventilation provided, and should be fully understood and considered to ensure code compliance.

However, for units covered in this document, refrigerant charge is less than “**m₁**” as defined in the UL/CSA 60335-2-40 standard ($m_1=3.9\text{lb} / 1.8\text{kg}$ for R454b). Therefore, special installation considerations will be minimal.

Model Nomenclature

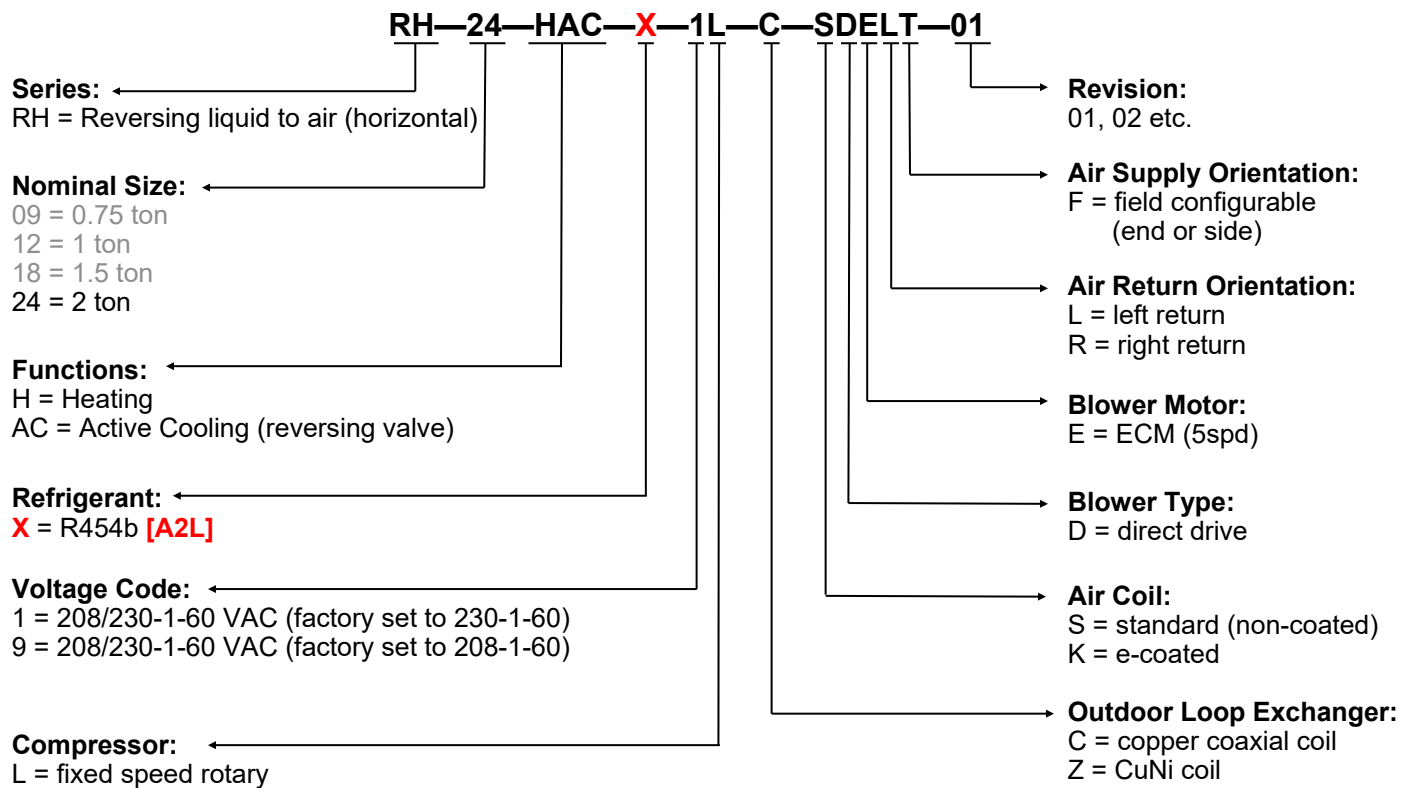

APPLICATION/AVAILABILITY TABLE											
MODEL	FUNCTION	REFRIGERANT	VOLTAGE	COMPRESSOR	OUTDOOR COIL	FAN/CASE	REVISIONS				
RH-24	HAC	X	1 9	L	C Z	SDELF SDERF	01				

This document applies only to the models and revisions listed in this table.

Maritime Geothermal Ltd. has a continuous improvement policy and reserves the right to modify specification data at any time without prior notice .

Features

- ⇒ Suitable for **space heating/cooling** or **heat recovery** applications
- ⇒ **Premium features** and **NORDIC reliability** in a **low cost** design
- ⇒ **R454b** refrigerant (GWP=466) is climate change-friendly. Note that R454b is an **A2L**.
- ⇒ **TUV listed** (CSA/UL/ETL equivalent)

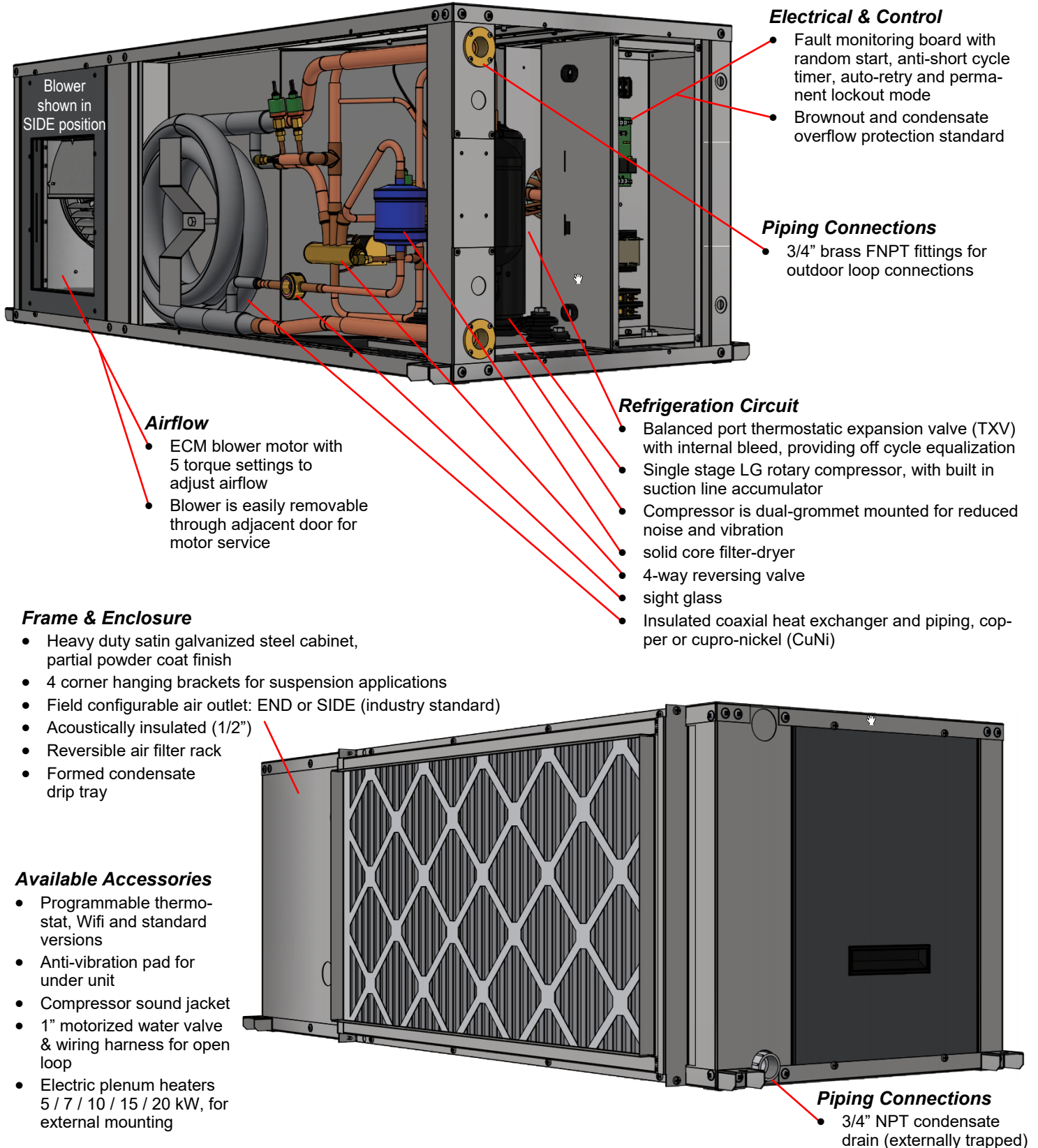

Electrical & Control

- Fault monitoring board with random start, anti-short cycle timer, auto-retry and permanent lockout mode
- Brownout and condensate overflow protection standard

Piping Connections

- 3/4" brass FNPT fittings for outdoor loop connections

Airflow

- ECM blower motor with 5 torque settings to adjust airflow
- Blower is easily removable through adjacent door for motor service

Refrigeration Circuit

- Balanced port thermostatic expansion valve (TXV) with internal bleed, providing off cycle equalization
- Single stage LG rotary compressor, with built in suction line accumulator
- Compressor is dual-grommet mounted for reduced noise and vibration
- solid core filter-dryer
- 4-way reversing valve
- sight glass
- Insulated coaxial heat exchanger and piping, copper or cupro-nickel (CuNi)

Frame & Enclosure

- Heavy duty satin galvanized steel cabinet, partial powder coat finish
- 4 corner hanging brackets for suspension applications
- Field configurable air outlet: END or SIDE (industry standard)
- Acoustically insulated (1/2")
- Reversible air filter rack
- Formed condensate drip tray

Available Accessories

- Programmable thermostat, Wifi and standard versions
- Anti-vibration pad for under unit
- Compressor sound jacket
- 1" motorized water valve & wiring harness for open loop
- Electric plenum heaters 5 / 7 / 10 / 15 / 20 kW, for external mounting

Piping Connections

- 3/4" NPT condensate drain (externally trapped)

Dimensions: Left Return

All dimensions in inches.

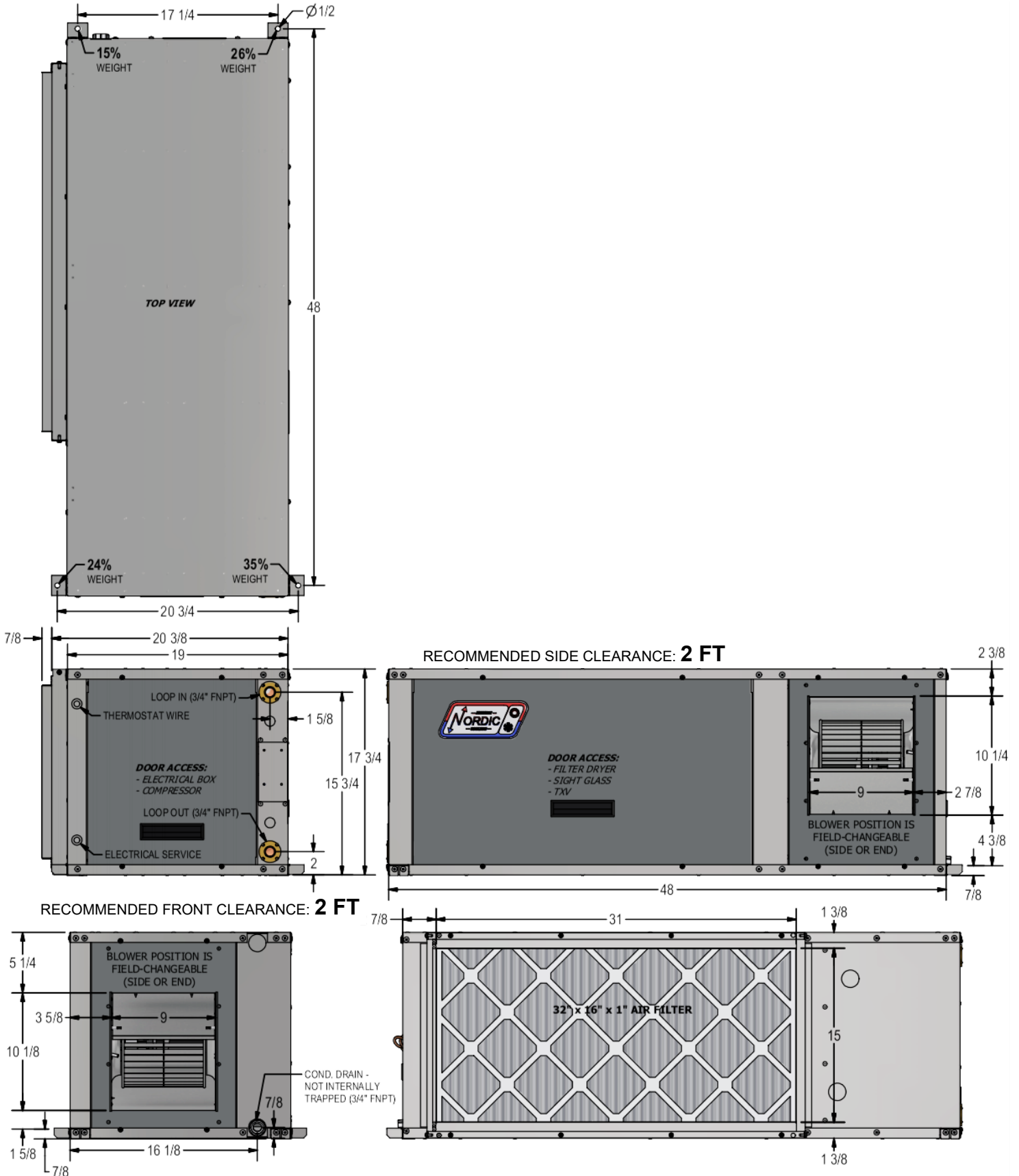

RECOMMENDED CLEARANCE FOR PANEL ADJACENT TO BLOWER:
2 FT

Dimensions: Right Return

All dimensions in inches.

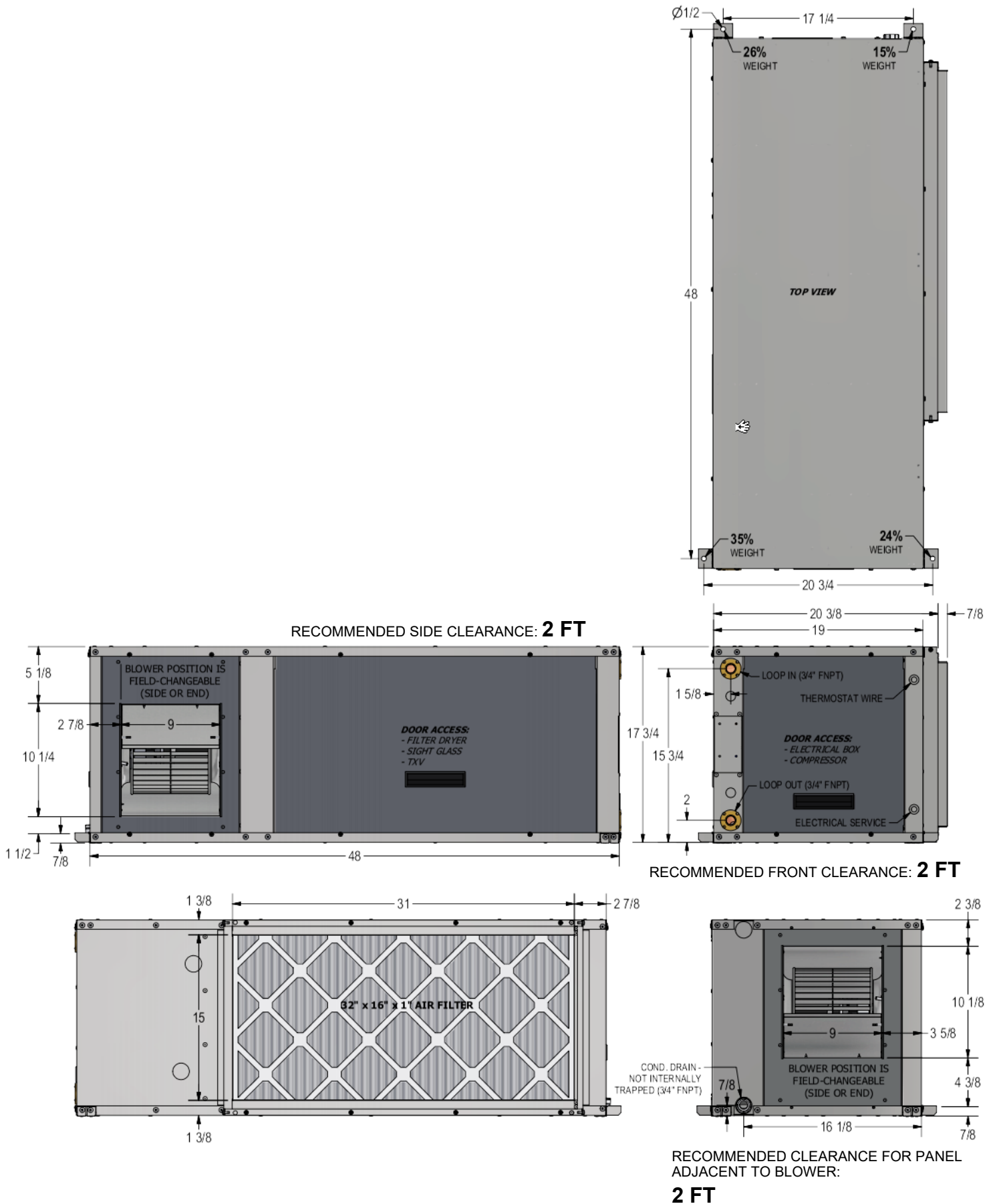

Specifications

Electrical Specifications (R454b)											
Code	Power Supply			Compressor		Fan	Outd. Circ.	FLA	MCA	Maximum Fuse/Breaker	Minimum Wire Size
	V-ø-Hz	MIN	MAX	RLA	LRA	RLA	Max A	Amps	Amps	Amps	ga
1	208/230-1-60	187	253	9.6	43	2.8	1.5	14.1	16.5	20	#12-2
9	208/230-1-60	187	253	9.6	43	2.8	1.5	14.1	16.5	20	#12-2



Refrigerant Charge				
MODEL	lb	kg	Refrigerant	Oil Type
RH-24	2.8	1.3	R454b	POE

- Note that R454b charge per refrigeration circuit is below '*m1*' as defined in the UL/CSA 60335-2-40 standard
- Refrigerant charge is subject to slight revision but always below *m1*; actual charge is indicated on the unit nameplate
- Oil capacity is marked on the compressor label

Shipping Information					
MODEL	SHIPPING WEIGHT	HANGING WEIGHT	DIMENSIONS inches (cm)		
	lb (kg)	lb (kg)	L	W	H
RH-24	250 (114)	208 (95)	48 (122)	21 (53)	18 (46)

See *Dimensions* on preceding pages for RH-series hanger weight distribution.

Operating Temperature Limits					
Loop	Mode	Parameter	°F	°C	Note
OUTDOOR (ground loop)	Heating (water/open loop)	Minimum ELT	41	5	
	Heating (antifreeze/ground loop)	Minimum ELT	23	-5	Adequate antifreeze concentration required.
	Heating	Maximum ELT	80	27	Reduce flow above this temperature.
	Cooling	Minimum ELT	41	5	Flow reduction may be required.
	Cooling	Maximum ELT	110	43	
INDOOR (air duct)	Heating	Minimum EAT	60	16	Reduce air flow if necessary during heating startup.
	Heating	Maximum EAT	100	38	
	Cooling	Minimum EAT	50	10	
	Cooling	Maximum EAT	100	38	Reduce air flow if necessary during cooling startup.

* Values in this table are for rated liquid and airflow values.

Loop Pressure Drop Data		Water 104°F		Water 50°F		15% Methanol 32°F		35% prop. glycol 32°F		
		gpm	L/s	psi	kPa	psi	kPa	psi	kPa	psi
RH-24	4	0.25	1.0	6.9	1.1	7.6	1.2	8.3	1.9	13
	5	0.32	1.4	9.7	1.5	10	1.7	12	2.3	16
	6	0.38	1.9	13	2.1	15	2.3	16	2.9	20
	7	0.44	2.5	17	2.7	19	3.0	21	3.8	26
	8	0.50	3.2	22	3.5	24	3.9	27	4.9	34
	9	0.57	4.1	28	4.3	30	4.8	33	6.0	41
	10	0.63	5.1	35	5.3	37	5.9	41	7.4	51

Standard Capacity Ratings

Standards C13256-1 / ISO13256-1 / ARI 13256-1

Standard Capacity Ratings - Ground Loop Heating* 60Hz										
EAT 68°F (20°C)					* 15% Methanol by Weight Ground Loop Fluid					ELT 32°F (0°C)
Model Size	Nominal Size	Liquid Flow		Airflow		Input Energy	Capacity		COP _H	
	tons	gpm	L/s	cfm	L/s	Watts	Btu/hr	kW	W/W	
24	2	8.0	0.50	800	380	1,561	18,800	5.5	3.53	

Standard Capacity Ratings - Ground Water Heating 60Hz									
EAT 68°F (20°C)					ELT 50°F (10°C)				
Model Size	Nominal Size	Liquid Flow		Airflow		Input Energy	Capacity		COP _H
	tons	gpm	L/s	cfm	L/s	Watts	Btu/hr	kW	W/W
24	2	8.0	0.50	800	380	1,704	25,200	7.4	4.33

Standard Capacity Ratings - Ground Loop Cooling* 60Hz											
EAT 80.6°F (27°C), RH=46%						* 15% Methanol by Weight Ground Loop Fluid					ELT 77°F (25°C)
Model Size	Size	Liquid Flow		Airflow		Input Energy	Capacity		EER	COP _c	
	tons	gpm	L/s	cfm	L/s	Watts	Btu/hr	kW	Btu/hr/W	W/W	
24	2	8.0	0.50	800	380	1,423	24,200	7.1	4.99	17.0	

Standard Capacity Ratings - Ground Water Cooling 60Hz										
EAT 80.6°F (27°C), RH=46%						ELT 59°F (15°C)				
Model	Size	Liquid Flow		Airflow		Input Energy	Capacity		EER	COP _c
	tons	gpm	L/s	cfm	L/s	Watts	Btu/hr	kW	Btu/hr/W	W/W
24	2	8.0	0.50	800	380	1,199	25,900	7.6	6.33	21.6

Performance Tables

RH-24-HAC-X-1L R454b, 60 Hz, KJS215

	OUTDOOR LOOP (15% Methanol)						ELECTRICAL			INDOOR LOOP (Air)						
	ELT (°F)	Evap. Temp.	Flow (gpm)	LLT (°F)	Delta T (°F)	Heat Abs. (Btu/hr)	Compressor Current (A)*	Fan** (W)	Input Power (W)	EAT (°F)	Cond. Temp.	Airflow (cfm)	LAT (°F)	Delta T (°F)	Heating (Btu/hr)	COP _H
HEATING	25	15	8.0	22	-3.0	11,700	5.6	185	1,507	68	101	800	87	19	16,600	3.23
	30	20	8.0	27	-3.3	13,100	5.8	185	1,547		103	800	89	21	18,200	3.45
	35	25	8.0	31	-3.7	14,600	6.1	185	1,584		105	800	91	23	19,800	3.66
	40	29	8.0	36	-4.1	16,200	6.3	185	1,622		107	800	93	25	21,600	3.90
	45	34	8.0	40	-4.6	17,900	6.5	185	1,663		109	800	95	27	23,400	4.12
	50	39	8.0	45	-5.0	19,600	6.7	185	1,705		110	800	97	29	25,200	4.33
	55	43	8.0	50	-5.5	21,400	6.9	185	1,749		112	800	100	32	27,200	4.56
	60	48	8.0	54	-6.0	23,300	7.0	185	1,800		114	800	102	34	29,300	4.77
	65	52	8.0	59	-6.5	25,200	7.2	185	1,854		116	800	105	37	31,400	4.96
	70	57	8.0	63	-7.0	27,200	7.3	185	1,914		118	800	107	39	33,600	5.14

	OUTDOOR LOOP (15% Methanol)						ELECTRICAL			INDOOR LOOP (Air @ 46% RH)								
	ELT (°F)	Cond. Temp.	Flow (gpm)	LLT (°F)	Delta T (°F)	Heat Rej. (Btu/hr)	Compressor Current (A)*	Fan** (W)	Input Power (W)	EAT (°F)	Evap. Temp.	Airflow (cfm)	LAT (°F)	Delta T (°F)	Latent (Btu/hr)	Sensible (Btu/hr)	Cooling (Btu/hr)	EER
COOLING	50	71	8.0	56	6.2	30,300	4.0	192	1,013	80.6	44	1200	67	-14	8,600	18,400	27,000	26.7
	55	77	8.0	61	6.2	30,000	4.3	192	1,124		44	1200	67	-14	8,300	18,000	26,300	23.4
	60	82	8.0	66	6.1	29,800	4.6	192	1,217		45	1200	67	-14	8,000	17,800	25,800	21.2
	65	88	8.0	71	6.1	29,500	4.8	192	1,292		45	1200	67	-14	7,700	17,600	25,300	19.6
	70	93	8.0	76	6.0	29,200	5.0	192	1,354		46	1200	67	-13	7,400	17,400	24,800	18.3
	75	98	8.0	81	6.0	29,000	5.2	192	1,405		46	1200	67	-13	7,100	17,300	24,400	17.4
	80	104	8.0	86	5.9	28,700	5.4	192	1,448		47	1200	68	-13	6,900	17,000	23,900	16.5
	85	109	8.0	91	5.9	28,300	5.5	192	1,483		47	1200	68	-13	6,600	16,800	23,400	15.8
	90	115	8.0	96	5.8	27,800	5.7	192	1,513		48	1200	68	-13	6,300	16,500	22,800	15.1
	95	120	8.0	101	5.7	27,200	5.8	192	1,538		48	1200	68	-12	6,000	16,100	22,100	14.4

METRIC

	OUTDOOR LOOP (15% Methanol)						ELECTRICAL			INDOOR LOOP (Air)						
	ELT (°C)	Evap. Temp.	Flow (L/s)	LLT (°C)	Delta T (°C)	Heat Abs. (kW)	Compressor Current (A)*	Fan** (W)	Input Power (W)	EAT (°C)	Cond. Temp.	Airflow (L/s)	LAT (°C)	Delta T (°C)	Heating (kW)	COP _H
HEATING	-3.9	-9.3	0.51	-5.6	-1.7	3.4	5.6	185	1,507	20.0	38.4	378	30.8	10.8	4.9	3.23
	-1.1	-6.7	0.51	-2.9	-1.8	3.8	5.8	185	1,547		39.5	378	31.8	11.8	5.3	3.45
	1.7	-4.1	0.51	-0.4	-2.1	4.3	6.1	185	1,584		40.5	378	32.8	12.8	5.8	3.66
	4.4	-1.6	0.51	2.1	-2.3	4.8	6.3	185	1,622		41.5	378	34.0	14.0	6.3	3.90
	7.2	1.1	0.51	4.6	-2.6	5.3	6.5	185	1,663		42.6	378	35.2	15.2	6.9	4.12
	10.0	3.6	0.51	7.2	-2.8	5.7	6.7	185	1,705		43.6	378	36.3	16.3	7.4	4.33
	12.8	6.2	0.51	9.7	-3.1	6.3	6.9	185	1,749		44.6	378	37.6	17.6	8.0	4.56
	15.6	8.8	0.51	12.3	-3.3	6.8	7.0	185	1,800		45.6	378	38.9	18.9	8.6	4.77
	18.3	11.3	0.51	14.7	-3.6	7.4	7.2	185	1,854		46.6	378	40.3	20.3	9.2	4.96
	21.1	13.9	0.51	17.2	-3.9	8.0	7.3	185	1,914		47.6	378	41.7	21.7	9.9	5.14

	OUTDOOR LOOP (15% Methanol)						ELECTRICAL			INDOOR LOOP (Air @ 46% RH)								
	ELT (°C)	Cond. Temp.	Flow (L/s)	LLT (°C)	Delta T (°C)	Heat Rej. (kW)	Compressor Current (A)	Fan** (W)	Input Power (W)	EAT (°C)	Evap. Temp.	Airflow (L/s)	LAT (°C)	Delta T (°C)	Latent (kW)	Sensible (kW)	Cooling (kW)	COP _c
COOLING	10.0	21.8	0.51	13.4	3.4	8.9	4.0	192	1,013	27.0	6.6	75.7	19.2	-7.8	2.5	5.4	7.9	7.83
	12.8	24.8	0.51	16.2	3.4	8.8	4.3	192	1,124		6.8	75.7	19.3	-7.7	2.4	5.3	7.7	6.86
	15.6	27.8	0.51	19.0	3.4	8.7	4.6	192	1,217		7.1	75.7	19.4	-7.6	2.3	5.2	7.6	6.21
	18.3	30.8	0.51	21.7	3.4	8.7	4.8	192	1,292		7.4	75.7	19.5	-7.5	2.3	5.2	7.4	5.74
	21.1	33.8	0.51	24.4	3.3	8.6	5.0	192	1,354		7.6	75.7	19.6	-7.4	2.2	5.1	7.3	5.36
	23.9	36.8	0.51	27.2	3.3	8.5	5.2	192	1,405		7.9	75.7	19.7	-7.3	2.1	5.1	7.2	5.10
	26.7	39.9	0.51	30.0	3.3	8.4	5.4	192	1,448		8.2	75.7	19.8	-7.2	2.0	5.0	7.0	4.84
	29.4	42.9	0.51	32.7	3.3	8.3	5.5	192	1,483		8.4	75.7	19.8	-7.2	1.9	4.9	6.9	4.63
	32.2	45.9	0.51	35.4	3.2	8.2	5.7	192	1,513		8.7	75.7	20.0	-7.0	1.9	4.8	6.7	4.43
	35.0	48.9	0.51	38.2	3.2	8.0	5.8	192	1,538		8.9	75.7	20.2	-6.8	1.8	4.7	6.5	4.22

** Fan power at 24.9Pa (0.10inH₂O) external static.

Engineering Guide Specifications

General

The liquid source reversing water-to-air heat pump shall be a single packaged reverse-cycle heating/cooling unit. The unit shall be listed by a nationally recognized safety-testing laboratory (NRTL), such as TUV, ETL, UL, or CSA. The unit shall be rated in accordance with applicable standards of the Air Conditioning, Heating, and Refrigeration Institute / International Standards Organization (AHRI/ISO) and/or Canadian Standards Association (CSA). The liquid source water to water heat pump unit, as manufactured by Maritime Geothermal, Petitcodiac, New Brunswick, shall be designed to operate correctly within liquid temperature ranges specified on the "Minimum and Maximum Operating Temperatures" page of this engineering specification document.

Factory Quality

Each unit shall be run tested at the factory with water circulating through the outdoor loop and air circulating through the indoor loop. Quality control system checks shall include: computerized nitrogen pressurized leak test, evacuation of refrigeration circuit to sustained vacuum, accurate system charge, detailed heating and cooling mode tests, and quality cross check all operational and test conditions to pass/fail criteria. Units tested without water and air flow are not acceptable. The units shall be warranted by the manufacturer against defects in materials and workmanship in accordance with the warranty section at the end of this document. Optional extended factory warranty coverage may be available.

Cabinet

Each unit shall be enclosed in a sheet metal cabinet. Cabinet shall be constructed of partially powder coated galvanized sheet metal of minimum 20 gauge. Sheet metal gauge shall be higher where structurally required. Design and construction of cabinet shall be such that it is rigid and passes the CSA/UL Loading Test requirements (200 lb roof test and 25 lb guard test). All panels shall be lined with minimum 1/2 inch [12.7 mm] thick acoustic type glass fiber insulation. All insulation shall meet the fire retardant provisions of NFPA 90A. This material shall also provide acoustical benefit. The unit must have a minimum of three access panels for serviceability. Units having only one access panel to compressor/heat exchangers/expansion device/refrigerant piping shall not be acceptable. The electrical box shall have separate holes and knockouts for entrance of line voltage and low voltage control wiring. All factory-installed wiring passing through factory knockouts and openings shall be protected from sheet metal edges at openings by plastic grommets.

Refrigerant Circuit

All units shall contain only one sealed refrigerant circuit, containing a hermetic motor rotary compressor with built in suction accumulator, coaxial heat exchanger, refrigerant to air exchanger, thermostatic expansion valve (TXV), reversing valve, factory installed high and low pressure safety switches, service ports, liquid line filter-dryer, and sight glass.

Refrigerant used shall have a global warming potential (GWP) of less than 500. For A2L refrigerants, a refrigerant leak detector shall not be required due to refrigerant charge being less than "m1" as defined in the UL/CSA 60335-2-40 standard.

Compressors shall be specified for heat pump duty with internal isolation consisting of two sets of rubber vibration isolators between the compressor and mounting plate, and between the mounting plate and cabinet floor. Compressor motors shall have internal overload protection.

The water to refrigerant heat exchangers shall consist of a steel outer jacket with twisted copper inner tube, designed and certified for 600 psig [4136 kPa] working pressure on the refrigerant side and 450 psig [3108 kPa] on the water side. Heat exchangers headered together in parallel shall use a reverse-return or symmetrical arrangement on the water side and symmetrical arrangement on the refrigerant side to ensure even flow splitting. Heat exchangers shall be insulated over all of their outside surface with minimum 3/8" thick closed cell insulation. Insulation consisting of 1/8" closed-cell insulating tape shall not be acceptable. Cupro-nickel (CuNi) inner tube shall be available as a factory option.

The refrigerant to air heat exchanger shall be a multi-circuit design with copper tubing and aluminum fins with refrigerant distributor for cooling mode. It shall be designed and certified for 650 psig [4482kPa] working pressure on the refrigerant side.

The thermostatic expansion valve shall be a balanced port bi-flow type with internal bleed and shall provide proper superheat control over the unit's operating range with minimal deviation from the superheat setpoint.

Fan/Blower

The blower shall be a squirrel cage type, constructed of corrosion resistant material, with unobstructed removable venturi to allow one-side servicing of fan motor. The fan return may be specified as left or right at the time of manufacture. The air outlet may be end or side discharge and shall be field configurable.

The fan motor shall be direct drive electrically commutated motor (ECM) with soft start and 5 selectable discrete torque levels.

Auxiliary Heat (Plenum Heater)

An optional plenum heater may be field installed outside the unit. Electrical control connections shall be supplied.

Condensate Tray

The condensate tray shall be large enough to catch any condensation that may drip from the refrigerant to air exchanger during cooling operation. The condensate drain shall be 3/4" NPT female socket fitting for external drain connection.

Piping and Connections

The unit shall have one set of primary water in and water out connections (outdoor loop). The primary connection type shall be 3/4" nominal female National Pipe Thread (NPT). All water connectors shall be rigidly mounted to cabinet with corrosion resistant fasteners to prevent relative movement. All water connectors shall be constructed of copper or brass material for corrosion resistance.

All internal water and refrigerant piping shall be insulated with minimum 3/8" thick closed cell insulation. Insulation consisting of 1/8" closed-cell insulating tape shall not be acceptable.

Electrical

Controls and safety devices shall be factory wired and mounted within the unit. Controls shall include a 24 volt alternating current (24VAC) class II control transformer with short circuit protection for providing power to all internal controls as well as a remote thermostat. Terminal strips with screw terminals shall be provided for field control wiring and power supply line connections. Units shall be name-plated for use with time delay fuses or circuit breakers.

Unit Control

The control system shall have the following features:

1. Anti-short cycle time delay on compressor operation. Time delay shall be a minimum of 5 minutes, for both thermostat demand and safety control reset starts. A test jumper shall be provided to disable this delay for unit commissioning and testing purposes. The unit shall revert to normal operation after a time delay if the test jumper is accidentally left in place.
2. Random compressor start delay of 0-120 seconds (in addition to 5 minute anti-short cycle timer) on unit power up to facilitate starting multiple units on one disconnect switch or after a power failure.
3. Compressor shutdown for high or low refrigerant pressures.
4. Condensate overflow protection, using two contacts in the drip tray (not a mechanical or electronic switch).
5. Low grid voltage or 'brownout' protection, which will prevent compressor operation if low voltage is detected.
6. Automatic intelligent reset: unit shall automatically restart 5 minutes after a trip if the fault has cleared. Should a fault reoccur again within 60 minutes then a permanent lockout shall occur, requiring cycling of the power to the unit in order to reset.

Maritime Geothermal works continually to improve its products. As a result, the design and specifications of any product may be changed without notice. Please contact Maritime Geothermal at 1-506-756-8135 or visit www.nordicghp.com for latest design and specifications. Purchaser's approval of this data set signifies that the equipment is acceptable under the provisions of the job specification. Statements and other information contained herein are not express warranties and do not form the basis of any commercial contract or other agreement between any parties, but are merely Maritime Geothermal's statement of opinion regarding its products.

LIMITED WARRANTY

MARITIME GEOTHERMAL LTD. warrants that its commercial geothermal heat pumps shall be free from defects in materials and workmanship for a period of ONE (1) YEAR after the date of installation or for a period of ONE (1) YEAR AND SIXTY (60) DAYS after the date of shipment, whichever occurs first. This warranty covers all internal components of the heat pump.

MARITIME GEOTHERMAL LTD. shall, at its option, repair or replace any part covered by this warranty. Defective parts shall be returned to MARITIME GEOTHERMAL LTD., transportation charges prepaid. Replacement or repaired parts and components are warranted only for the remaining portion of the original warranty period.

This warranty is subject to the following conditions:

1. The geothermal heat pump must be properly installed and maintained in accordance with MARITIME GEOTHERMAL LTD. guidelines.
2. The installer must complete the **Startup Record** and return it to MARITIME GEOTHERMAL LTD. within 21 days of unit installation.
3. For new construction, it is the responsibility of the building or general contractor to supply temporary heat to the structure prior to occupancy. Geothermal heat pumps are designed to provide heat only to the completely finished and insulated structure. Startup of the unit shall not be scheduled prior to completion of construction and final duct installation for validation of this warranty.
4. It is the customer's responsibility to supply the proper quantity and quality of water or properly sized ground loop with adequate freeze protection.

If a geothermal heat pump manufactured by MARITIME GEOTHERMAL LTD. fails to conform to this warranty, MARITIME GEOTHERMAL LTD.'s sole and exclusive liability shall be, at its option, to repair or replace any part or component which is returned by the customer during the applicable warranty period set forth above, provided that (1) MARITIME GEOTHERMAL LTD. is promptly notified in writing upon discovery by the customer that such part or component fails to conform to this warranty; (2) the customer returns such part or component to MARITIME GEOTHERMAL LTD., transportation charges prepaid, within (30) thirty days of failure, and (3) MARITIME GEOTHERMAL LTD.'s examination of such component discloses to its satisfaction that such part or component fails to conform to this warranty and the alleged defects were not caused by accident, misuse, neglect, alteration, improper installation, repair or improper testing. MARITIME GEOTHERMAL LTD. will not be responsible for any consequential damages or labour costs incurred. In addition, MARITIME GEOTHERMAL LTD. will not be responsible for the cost of replacement parts purchased from a third party.