

# Application, Installation, & Service Manual

## W-Series Liquid to Water Heat Pumps

Single-Stage **R454b**  
Model Sizes 12-18

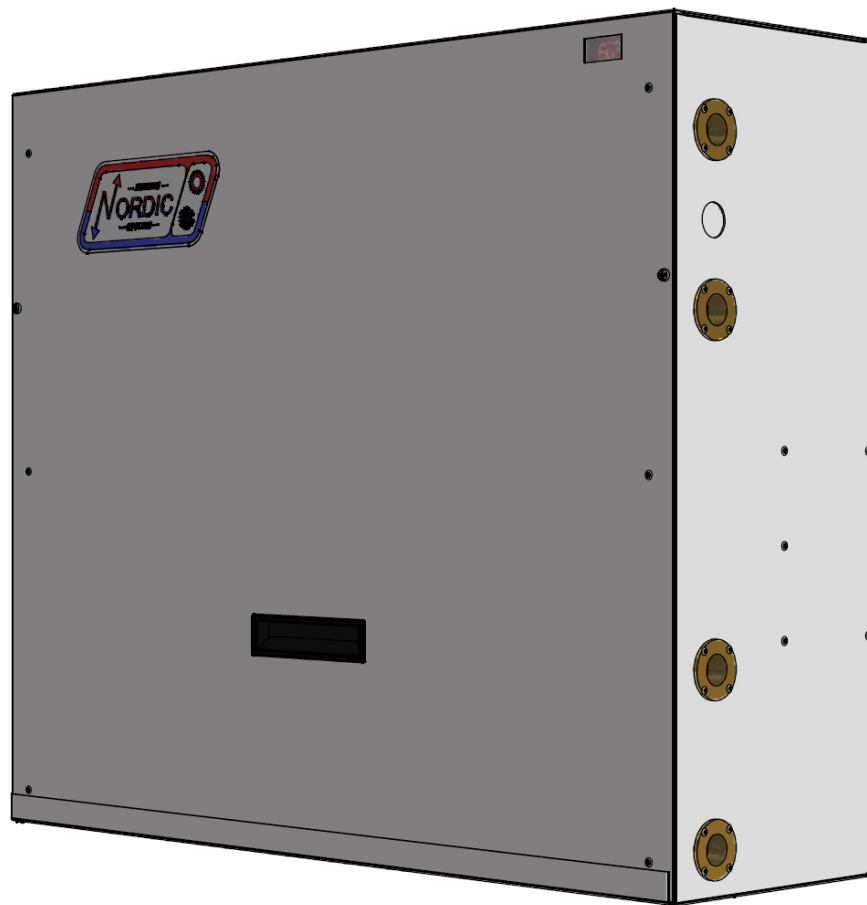

Maritime Geothermal Ltd.  
P.O. Box 2555, 170 Plantation Road  
Petitcodiac, NB E4Z 6H4  
(506) 756-8135



info@nordicghp.com  
www.nordicghp.com  
002744MAN-02

LOOK FOR GREY TEXT BOXES LIKE THIS ONE THROUGHOUT MANUAL FOR  
**A2L-SPECIFIC WARNINGS / INSTRUCTIONS**



## **A2L refrigerant: mildly flammable.**

Installation and service work should only be performed by properly certified technicians with **A2L-specific** training. See also [Service Procedures](#) chapter.



Refrigerant does NOT have an odour so is only detectable with suitable field instruments.

Do NOT pierce or burn. Do NOT use flame to defrost or clean. Check for presence of refrigerant using a detector before initiating any service work, especially work involving torches.

For units covered in this manual, refrigerant charge is less than “ $m_1$ ” as defined in the UL/CSA 60335-2-40 standard ( $m_1=3.9\text{lb} / 1.8\text{kg}$  for R454b). Therefore, an **A2L leak detection** system is not required.

Installation of a unit with **A2L** refrigerant may require calculations involving the size of the mechanical room and/or rooms served by the unit. However, the equipment covered by this manual is likely to be exempt since refrigerant charge is less than “ $m_1$ ” as defined in the UL/CSA 60335-2-40 standard.

## **GENERAL SAFETY PRECAUTIONS**



To avoid electric shock, which can cause serious injury or death, ensure all access panels are in place and properly secured before applying power to the unit. Before performing service or maintenance on the heat pump system, ensure all power sources are **DISCONNECTED**.



Safety glasses and work gloves should be worn at all times whenever a heat pump is serviced. A fire extinguisher and proper ventilation should be present whenever brazing is performed.



Venting refrigerant to atmosphere is illegal. A proper refrigerant recovery system must be employed whenever repairs require removal of refrigerant from the heat pump.



This appliance is not intended for intervention by persons with reduced physical, sensory, or mental capabilities or lack of experience and knowledge, unless suitably supervised. Children should be prevented from playing with appliance.

# Model Nomenclature

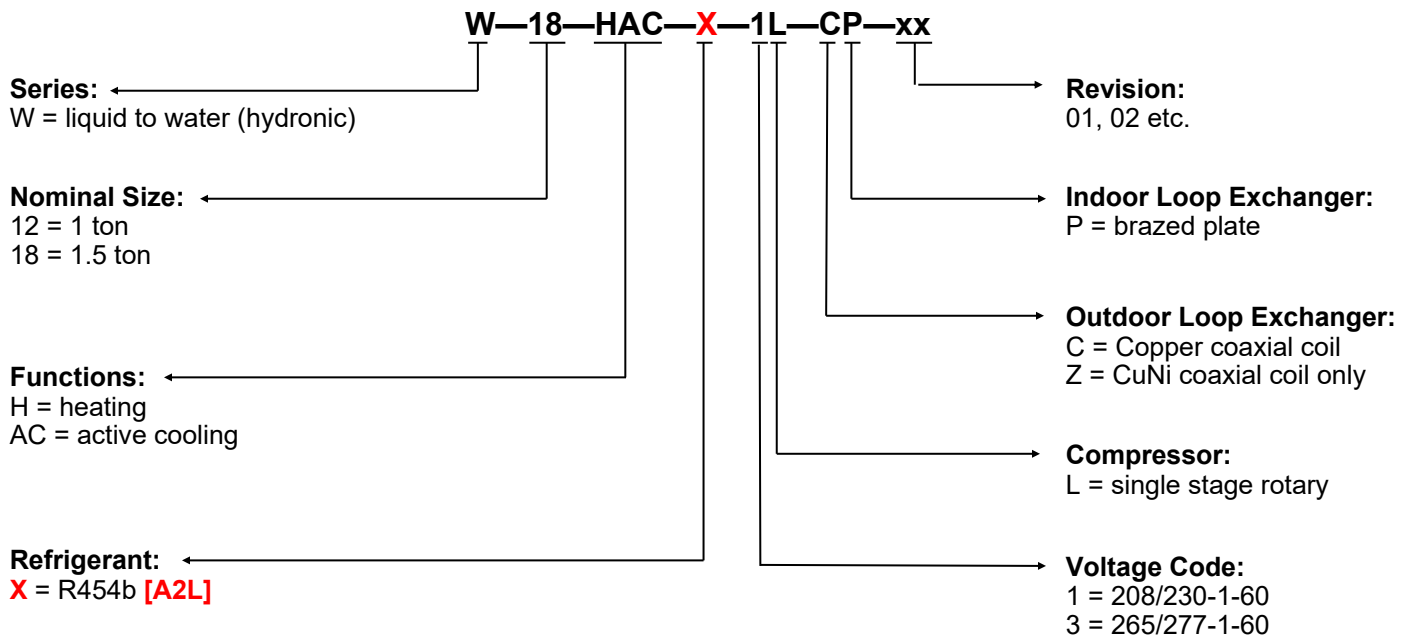

APPLICATION/AVAILABILITY TABLE										
MODEL SERIES	MODEL SIZE	FUNCTION	REFRIGERANT	VOLTAGE	COMPRESOR	OUTDOOR COIL	INDOOR COIL	REVISIONS		
W	12 18	HAC	X	1 3	L	C Z	P	02		

This manual applies only to the models and revisions listed in this table

Maritime Geothermal Ltd. has a continuous improvement policy and reserves the right to modify specification data at any time without prior notice .

# Table of Contents

<b>Tables, Figures, &amp; Documents</b>	<b>5</b>	<b>000619INF - Ground Water Disposal Methods</b>	<b>33</b>
<b>W-Series System Description</b>	<b>6</b>	<b>Startup Procedure</b>	<b>34</b>
General Overview	6	Pre-start Inspection	34
1. Heating Mode	6	Unit Startup	35
2. Cooling Mode	6	Startup Record	36
<b>W-Series Sizing</b>	<b>7</b>	<b>Routine Maintenance</b>	<b>37</b>
Heat Pump Sizing	7	Heat Exchanger Flushing Procedure - Open Loop	37
Auxiliary Heat Sizing	7	Heat Exchanger Flushing Procedure - Closed Loop	37
<b>Installation Basics</b>	<b>8</b>	<b>Troubleshooting Guide</b>	<b>38</b>
A2L's	8	<b>Service Procedures</b>	<b>45</b>
Unpacking the unit	8	Servicing a Unit with an A2L Refrigerant	45
Unit Placement	8	Pumpdown Procedure	47
Sample Bill of Materials - Ground Loop Installations	9	General Repair Procedure	47
Sample Bill of Materials - Open Loop Installations	9	Vacuuming & Charging Procedure	47
<b>Wiring</b>	<b>10</b>	Compressor Replacement Procedure	48
Power Supply Connections	10	Decommissioning	49
Indoor Loop Circulator Pump Wiring	10	<b>Model Specific Information</b>	<b>50</b>
Outdoor Loop Pump Module Wiring (Ground Loop Only)	10	Refrigerant Charge	50
Control Transformer	10	Shipping Information	50
Open/Closed Loop Wiring	10	Operating Temperature Limits	50
Control Requirements	11	Required Indoor & Outdoor Loop Flow Rates	50
Manual Cooling Mode Switchover	11	Electrical Specifications	50
Auxiliary Heat	11	Pressure Drop Data	51
Internal Aquastat Operation	11	Standard Capacity Ratings	52
Safety Controls	12	Performance Tables: W-12	53
Refrigerant Vent Fan Connections (none)	12	Performance Tables: W-18	54
002508CDG - Typ. Aux Heat & Circ. Wiring w/Int. Aquastat	13	Wiring Diagram (208/230-1-60)	55
002375QSS - AltSource Tanks: Getting Started	14	Wiring Diagram (265/277-1-60)	56
002067CDG - Typical Zone Wiring (Heating Only)	15	Refrigeration Circuit Diagram	57
002509CDG - Typ. Control & Zone Wiring (Htg & Cooling)	16	Dimensions	58
<b>Piping</b>	<b>17</b>	<b>Warranty</b>	<b>59</b>
Indoor Loop	17		
Outdoor Loop	17		
002366PDG - Recommended Hydronic Buffer Tank Piping	18		
002367PDG - Auxiliary Boiler Piping	19		
002252PDG - 2-Tank System with a Reversing Heat Pump	20		
002288PDG - 2-Tank Simultaneous Heating/Cooling	21		
000530PDG - Typical Zone Types	22		
<b>Ground Loop Installations</b>	<b>23</b>		
Circulator Pump Module	23		
Flushing & Purging	23		
Adding Antifreeze Solution	24		
Initial Pressurization	24		
Pipe Insulation	24		
000608INF - Typical Horiz. Ground Loop Configuration	25		
000609INF - Typical Vert. Ground Loop Configuration	26		
000906CDG - Circulator Pump Module Installation	27		
000629PDG - Pump Module Inst - 2 Units on 1 Loop	28		
<b>Open Loop Installations</b>	<b>29</b>		
Well Water Temperature	29		
Well Water Flow	29		
Well Water Quality	29		
Water Discharge Methods	29		
Water Valve	30		
Water Flow Control	31		
Submersible Pump Selection	31		
Submersible Pump Power Draw	31		
Plumbing the Heat Pump	31		
Pipe Insulation	31		
000907CDG - Typical Open Loop Installation	32		

# Tables & Documents

## Tables

<a href="#">Table 1 - Heat Pump Size vs. Heated Area for a Ground Loop System</a>	7
<a href="#">Table 2 - Heat Pump Size vs. Heated Area for an Open Loop System</a>	7
<a href="#">Table 3 - Auxiliary Heat Sizing</a>	7
<a href="#">Table 4 - Power Supply Connections</a>	10
<a href="#">Table 5a - Indoor Loop Circulator Connections</a>	10
<a href="#">Table 5b - Outdoor Loop Circulator Connections</a>	10
<a href="#">Table 6 - Control Signal Description</a>	11
<a href="#">Table 7 - Internal Aquastat Settings</a>	11
<a href="#">Table 8 - Typical Aquastat Setpoints</a>	11
<a href="#">Table 9 - Control Board Fault Codes</a>	12
<a href="#">Table 10 - Buffer Tank Size</a>	17
<a href="#">Table 11 - Antifreeze Percentages</a>	24
<a href="#">Table 12 - Volume of Fluid per 100ft. Of Pipe</a>	24
<a href="#">Table 13 - Required Flow</a>	29
<a href="#">Table 14 - Refrigerant Charge</a>	50
<a href="#">Table 15 - Shipping Information</a>	50
<a href="#">Table 16 - Operating Temperature Limits</a>	50
<a href="#">Table 17 - Required Indoor &amp; Outdoor Loop Flow Rates</a>	50
<a href="#">Table 18 - Electrical Specifications</a>	50
<a href="#">Table 19 - Loop Pressure Drop Data</a>	51
<a href="#">Table 20 - Standard Capacity Ratings - Ground Loop Heating 60Hz</a>	52
<a href="#">Table 21 - Standard Capacity Ratings - Ground Loop Cooling 60Hz</a>	52
<a href="#">Table 22 - Standard Capacity Ratings - Ground Water Heating 60Hz</a>	52
<a href="#">Table 23 - Standard Capacity Ratings - Ground Water Cooling 60Hz</a>	52

## Documents

<a href="#">002508CDG - Typical Auxiliary Heat &amp; Circulator Wiring w/ Internal Aquastat</a>	13
<a href="#">002375QSS - AltSource Tanks: Getting Started</a>	14
<a href="#">002067CDG - Typical Zone Wiring (Heating Only)</a>	15
<a href="#">002509CDG - Typical Control &amp; Zone Wiring (Heating &amp; Cooling, Automatic Switchover)</a>	16
<a href="#">002366PDG - Recommended Hydronic Buffer Tank Piping</a>	18
<a href="#">002367PDG - Auxiliary Boiler Piping</a>	19
<a href="#">002252PDG - Two Tank System Piping with a Reversing Heat Pump</a>	20
<a href="#">002288PDG - Two Tank Simultaneous Heating / Cooling</a>	21
<a href="#">000530PDG - Typical Zone Types for Hydronic Applications</a>	22
<a href="#">000608INF - Typical Horizontal Ground Loop Configuration</a>	25
<a href="#">000609INF - Typical Vertical Ground Loop Configuration</a>	26
<a href="#">000906CDG - Geo-Flo Circulator Pump Module Installation</a>	27
<a href="#">000629PDG - Circulator Pump Module Installation - Two Units on One Ground Loop</a>	28
<a href="#">000907CDG - Typical Ground Water (Open Loop) Installation</a>	32
<a href="#">000619INF - Ground Water Disposal Methods</a>	33
<a href="#">002380SCH - W-HAC Schematic Diagram 208/230-1-60 Rotary</a>	55
<a href="#">002383SCH - W-HAC Schematic Diagram 265/277-1-60 Rotary</a>	56
<a href="#">003104RCD - W-HAC Refrigeration Circuit</a>	57

# W-Series System Description

## General Overview

The Nordic W-series, a geothermal standard for more than 30 years, is a package water source heat pump that can heat or chill water for hydronic applications like in-floor heating, low temperature radiators, or hydronic air handlers/fan coils.

Most or all water-to-water heat pumps on the market start at 2 tons in nominal size, making them too large for single zone, decentralized, or passive home applications. The model sizes described here are 1-1.5 tons in capacity, making them ideal for such applications.

Being a 'ground source', 'water source', 'geoexchange', or 'geothermal' heat pump, the W-series does require either a **closed ground loop** or **open loop water well** for a heat source/sink. There is no outdoor fan unit for ground source heat pumps.

The outdoor loop hydronic heat exchanger is a heavy duty coaxial copper / steel model with optional CuNi inner tube available. The indoor loop heat exchanger is a stainless steel brazed plate model, for compact size and high heating performance. Compressor is a single-stage rotary model. A single thermostatic expansion valve (TXV) regulates superheat. The cabinet is constructed from powder coated galvanized sheet metal, and is a slim style that can be wall mounted.

## 1. Heating Mode

In heating mode, the heat pump heats water in a buffer tank to a user-adjustable setpoint temperature, while extracting heat from the outdoor loop. A buffer tank is required, in order to maintain control over the water temperature and avoid mis-

matching between the heat pump's output and the heat load. A built-in aquastat determines when the buffer tank temperature has fallen below the user-adjustable setpoint and hydronic heating is required. An external backup heating device can be activated through dry contacts via a built-in 0-2 hour timer.

If a closed ground loop is used, the circulation pumps are powered and controlled by the heat pump; if open loop, a water valve is opened by the heat pump during heating operation and closed when the heat pump is idle.

Hydronic heating systems are easily zoned, and zones may be in-floor heating, hydronic air handlers, or other hydronic devices suitable for water temperatures less than 120°F (49°C). When a zone requires heat, its zone thermostat calls for a zone circulator pump or zone valve to activate, so that hot water from the buffer tank is sent to the zone requiring heat. Note that there is no direct connection between the zone thermostat and the heat pump, the functions of each being separated by the buffer tank.

## 2. Cooling Mode

In cooling mode, the heat pump cools water in the buffer tank. Heat is rejected to the outdoor loop.

Hydronic cooling is usually done through hydronic air handlers, which have condensate drains to remove water that is removed while dehumidifying the air. In less humid climates or when a separate dehumidifier is present, in-floor or radiant cooling is sometimes performed; such systems can't remove humidity from the air. In this case, care must be taken to ensure the cooling surface does not fall below the dew point temperature in order to prevent condensation on floor surfaces.

Installation example of a larger (W-25 to 80) Nordic water to water heat pump



# W-Series Sizing

## Heat Pump Sizing

The following table is a rough guideline as to the size of space each heat pump size can handle for **ground loop (closed loop)** installations.

TABLE 1 - Heat Pump Size vs. Heated Area for a Ground Loop System		
Model Size	ft <sup>2</sup>	m <sup>2</sup>
12	400	37
18	600	56

The following table is a rough guideline as to the size of home each heat pump size can handle for **ground water (open loop)** installations.

TABLE 2 - Heat Pump Size vs. Heated Area for an Open Loop System		
Model Size	ft <sup>2</sup>	m <sup>2</sup>
12	500	47
18	750	70

**THE TABLES ABOVE ARE FOR INFORMATION ONLY. They should not be used to select a final unit size.** They simply show on average what size unit is required for a typical space or home (main level and below grade basement) with R20 walls, R40 ceiling and average size and number of windows. The Heated Area is the area of the main level. The tables account for a basement the same size as the heated area.

**IT IS HIGHLY RECOMMENDED THAT A PROPER HEAT LOSS/GAIN ANALYSIS BE PERFORMED BY A PROFESSIONAL WITH APPROVED CSA F-280 SOFTWARE BEFORE SELECTING THE SIZE OF UNIT REQUIRED FOR THE APPLICATION. For heating dominant climates, we recommend sizing the unit to 100% of the heating design load for maximum long term efficiency with minimal supplementary heat. The unit should be installed as per CSA standard 448.2-02. For ground loop applications, the ground loop should be designed using suitable software with a multi-year analysis.**

The analysis will result in a heat load for the coldest day, which is influenced by, for example, the number of levels, the size of the windows, the orientation of the home, attached garage, bonus rooms, walk-in basement, and coldest outdoor temperature for the region.

A heat pump model size can be selected by comparing the calculated heat load to the standard capacity ratings, which are listed in the [Model Specific Information](#) section of this manual. For 100% heat pump sizing, choose a heat pump with a standard capacity rating that matches or just slightly exceeds the calculated heat load.

Closed ground loops are normally designed to reach a minimum temperature of just below freezing at the end of the heating season, in order to take advantage of the latent heat of groundwater (at least in northern climates). Hence, the Standard Capacity Ratings for Ground Loop Heating should apply in all northern climates.

The Standard Capacity Ratings for Ground Water (open loop) heat pumps assume a well water temperature of 50°F (10°C). If the groundwater is not close to this temperature, it will be

necessary to consult the more detailed performance tables later in the section for heat pump output at a different Entering Liquid Temperature (ELT).

In cooling dominant climates, the heat pump should be similarly sized using the Ground Loop Cooling or Ground Water Cooling Standard Capacity Ratings. **Even in northern heating dominant climates, it should be ensured that 100% of the cooling load will be covered when sizing the heat pump, since there is normally no auxiliary or backup cooling available.**

## Auxiliary Heat Sizing

The easiest way to provide auxiliary or backup heat for new installations is by installing a buffer tank that has electric elements. Buffer tanks with elements that are certified for space heating use are available as accessories from Maritime Geothermal Ltd., or others may be used. For retrofits, often an existing heat device can be used for auxiliary heat. Note that if the geothermal heat pump is sized for 100% of the coldest day heat load, auxiliary heat is not strictly required (unlike with an air source heat pump).

For full backup, an option which is good for peace of mind (should the heat pump experience a problem) but can require significant electrical service capacity, an element size can be chosen that covers 100% of the coldest day heat load, according to the heat loss analysis mentioned in the last section. If a heat loss analysis is not available, the following table may be used as a guide.

TABLE 3 - Auxiliary Heat Sizing	
Model Size	Tank Element Size Recommended
12	3000 W
18	5000 W

For heat pumps that are sized to cover less than 100% of the coldest day heat load, the elements can be sized to make up the coldest-day difference. The CSA installation standard allows geothermal heat pumps to be sized to as little as 75% of the coldest day heat load.

For retrofits, the existing heating device (e.g. an electric or gas boiler) may be used for auxiliary heat. It should be wired as described in the [Wiring](#) section, and piped in a parallel arrangement as per the diagram in the [Piping](#) section.

# Installation Basics



## A2L-SPECIFIC WARNING / INSTRUCTION

The heat pump uses **R454b**, an **A2L** refrigerant which is a classification meaning “slightly flammable”.

Safety measures to mitigate **A2L** refrigerant leaks are outlined in standard **UL/CSA 60335-2-40** and also **CSA B52:23**.

These units are classified as “enhanced tightness refrigerating systems” with refrigerant charge  $m_c < m_1$  for the purposes of UL/CSA 60335-2-40, clause GG.10. This has two significant consequences:

- A unit-mounted refrigerant leak detector is not required.
- For single unit installation, most or all requirements related to A2L refrigerants for mechanical room size and mechanical room ventilation do not apply.

*If there are multiple units containing A2L refrigerants in one mechanical room or at one site, it is highly recommended that a **mechanical consulting engineer** be involved, whether for new installation or replacement of non-A2L units. This is because the mechanical room requirements can be onerous and also difficult to decipher for the layperson.*

## Unpacking the Unit

When the heat pump arrives it should be unpacked to determine if any damage has occurred during shipment. Any visible damage should be noted on the carrier's freight bill and a suitable claim filed.

## Unit Placement

The placement of a hydronic heat pump has negligible effects on the efficiency and operation of the system. The hydronic layout may make a particular location ideal for the unit.

The heat pump is designed to be wall-mounted. See the [Dimensions](#) section toward the end of this document for mounting bolt pattern on wall. Four 5/16” lag bolts into solid wood or equivalent must be used to carry the significant weight of the heat pump and water in heat exchangers.

The heat pump cover should remain unobstructed for a distance of **two feet** to facilitate servicing and general maintenance.

If floor mounted, provision should be made to eliminate tipping hazard. Raising the indoor unit off the floor a few inches is generally a good practice since this will prevent rusting of the bottom panel of the unit and deaden vibrations. A piece of 2” Styrofoam can be placed under the unit.

## Sample Bill of Materials - Ground Loop Installations

Although not exhaustive, following is a list of materials needed for a typical ground loop installation:

### FROM MARITIME GEOTHERMAL

- W SERIES HEAT PUMP
- BUFFER TANK W/ELEMENTS \_\_kW
- EXTERNAL AQUASTAT (ONLY FOR HEAT/COOL AUTO SWITCHOVER CONFIGURATIONS)
- P/T PORTS AND HOSE ADAPTERS (2)
- PUMP PACK
- PIPE ADAPTERS FOR PUMP PACK

### OPTIONAL FROM MARITIME GEOTHERMAL

- ANTI-VIBRATION PAD
- SOUND JACKET

### GROUND LOOP

- 3/4" PE PIPE
- 1-1/4" PE PIPE
- PE PIPE FITTINGS
- 1" CLEAR HOSE (HEAT PUMP TO PUMP PACK)
- HOSE CLAMPS
- ANTIFREEZE: METHANOL OR PROP. GLYCOL

### ZONES

- CIRCULATOR: HEAT PUMP TO TANK
- 3/4" PIPE & FITTINGS: HEAT PUMP TO TANK
- ZONES CIRCULATOR(S)
- ZONE TRANSFORMER & CIRC CONTACTOR
- ZONE VALVES (IF NOT INDIVIDUAL PUMPS)
- IN-FLOOR PIPING
- OTHER AIR HANDLERS, DUCTING
- ZONE THERMOSTATS
- RELAYS OR ZONE CONTR. (REVERSING SYSTEMS)
- ZONE SUPPLY & RETURN HEADERS
- PIPE & FITTINGS TO ZONES
- EXPANSION TANK

### ELECTRICAL

- HEAT PUMP SERVICE WIRE
- BUFFER TANK ELEMENT SERVICE WIRE
- HEAT PUMP BREAKER
- BUFFER TANK ELEMENT BREAKER
- CONTACTOR & ELEC. BOX (IF NOT WITH TANK)
- THERMOSTAT WIRE 18-4
- THERMOSTAT WIRE 18-2
- FORK TERMINALS FOR TSTAT WIRE (6)
- 2" STYROFOAM INSUL. (IF PAD NOT PURCHASED)

## Sample Bill of Materials - Open Loop Installations

Although not exhaustive, following is a list of materials needed for a typical open loop (groundwater) installation:

### FROM MARITIME GEOTHERMAL

- W SERIES HEAT PUMP
- BUFFER TANK W/ELEMENTS \_\_kW
- EXTERNAL AQUASTAT (ONLY FOR HEAT/COOL AUTO SWITCHOVER CONFIGURATIONS)
- P/T PORTS AND HOSE ADAPTERS (2)
- DOLE VALVE
- TACO OR SOLENOID VALVE

### OPTIONAL FROM MARITIME GEOTHERMAL

- ANTI-VIBRATION PAD
- SOUND JACKET

### WATER SYSTEM

- 3/4" BLACK PLASTIC WATER PIPE
- 3/4" BARBED FITTINGS & HOSE CLAMPS
- SUBMERSIBLE PUMP (IF NOT EXISTING)
- PRESSURE TANK (IF NOT EXISTING)
- CYCLE STOP VALVE (OPTIONAL)

### ZONES

- CIRCULATOR: HEAT PUMP TO TANK
- 3/4" PIPE & FITTINGS: HEAT PUMP TO TANK
- ZONES CIRCULATOR(S)
- ZONE TRANSFORMER & CIRC CONTACTOR
- ZONE VALVES (IF NOT INDIVIDUAL PUMPS)
- IN-FLOOR PIPING
- OTHER AIR HANDLERS, DUCTING
- ZONE THERMOSTATS
- RELAYS OR ZONE CONTR. (REVERSING SYSTEMS)
- ZONE SUPPLY & RETURN HEADERS
- PIPE & FITTINGS TO ZONES
- EXPANSION TANK

### ELECTRICAL

- HEAT PUMP SERVICE WIRE
- BUFFER TANK ELEMENT SERVICE WIRE
- HEAT PUMP BREAKER
- BUFFER TANK ELEMENT BREAKER
- CONTACTOR & ELEC. BOX (IF NOT WITH TANK)
- THERMOSTAT WIRE 18-4
- THERMOSTAT WIRE 18-2
- FORK TERMINALS FOR TSTAT WIRE (6)
- 2" STYROFOAM INSUL. (IF PAD NOT PURCHASED)

# Wiring

## Power Supply Connections

Power supply for the heat pump from the breaker panel is supplied to the unit via a 0.875" knockout. There are also two 0.875" knockouts for electrical connections to the indoor circulator, ground loop circulator pump, and controls. There is one additional 1/2" opening with plastic grommet (grommet hole is 3/8") for connections to the controls.

A schematic diagram (SCH) can be found on the electrical box cover of the unit as well as in the [Model Specific Information](#) section of this manual. The **Electrical Specifications** table in the [Model Specific Information](#) section contains information about the wire and breaker size.



**IMPORTANT NOTE: A properly qualified electrician should be retained for all connections to the heat pump and associated controls. The connections to the heat pump MUST CONFORM TO LOCAL CODES.**

Line	Description	Voltages
L1	Line 1	All
L2	Line 2	All
N**	Neutral	230-1-60**
GND	Ground	All (connect to ground lug)

\*\* N is required only if connecting 115VAC circulators to the unit. The heat pump itself does not require a neutral.

## Indoor Loop Circulator Pump Wiring

The unit has provisions for connecting the indoor circulator pump (between the heat pump and buffer tank) so that it will be turned on **before** the compressor operates. *The indoor circulator must be connected in the following way to avoid flow switch safety trips.*

Connect the indoor circulator pump to the appropriate two terminals (115V & 115/230 or 230V & 115/230) of the terminal strip marked **Indoor Circulator Pumps**. Ground wires should be connected to the ground lug in the electrical box.

Signal	Description
115	Connection for 115V circulator
115/230	Connection for 115V or 230V circulator
230	Connection for 230V circulator
Use a 2-conductor 14ga cable.	
277	Connection for 265/277V circulator
277	(heat pump voltage code 3 only)
Use a 2-conductor 14ga cable.	

## Outdoor Loop Pump Module Wiring (Ground Loop Only)

The heat pump has provisions for connecting the ground loop pump module so that the pumps will be turned on whenever the compressor operates.

Connect the outdoor circulator pump or module to the appropriate two terminals (115V & 115/230 or 230V & 115/230) of the terminal strip marked **Outdoor Circulator Pumps**. Ground wires should be connected to the ground lug in the electrical box.

Signal	Description
115V	Connection for 115V circulator
115/230	Connection for 115V or 230V circulator
230V	Connection for 230V circulator
Use a 2-conductor 14ga cable.	
277	Connection for 265/277V circulator
277	(heat pump voltage code 3 only)
Use a 2-conductor 14ga cable.	

## Control Transformer

The low voltage controls are powered by a 40VA class II transformer. It has impedance protection, so if it is shorted out needs to be replaced.



**IMPORTANT NOTE: For 208/230VAC-1-60 units, if connecting to 208VAC power supply move the red wire connected to the 240 terminal of the transformer to the 208 terminal of the transformer.**

## Control Requirements

Since an aquastat is built into the heat pump, no external controls are normally required. The aquastat comes with a probe with 96" (8 ft / 2.4 m) of wire, which should be extended through the knockout on the right side of the cabinet and placed in a dry well near the top of the buffer tank. If a dry well is not available, it may be possible to affix the probe to the tank inside the insulation.

The internal aquastat is capable of controlling both heating and cooling mode operation (operating both compressor and reversing valve), with a manual switchover required between heating and cooling modes.

Alternatively, an accessory external aquastat or other controller with dry contacts may be used, **but to control cooling mode only**. This would be necessary if the heat pump needs to switch into cooling mode automatically, when a zone controller or a network of room thermostats and relays demand a switchover. Two connections are required, as outlined in the below table. Note that, if used, the **OEXT** signal (which turns off the on-board heating aquastat) must be present during cooling season even when there is no cooling demand. This is to avoid repeated heating and cooling of the buffer tank on demand cycling, causing high electricity consumption.

## Manual Cooling Mode Switchover

When using just the built-in aquastat, all that is required to switch to cooling mode is to lower the **F1** setpoint temperature, by following the procedure outlined below and also on the schematic (wiring) diagram on the electrical box cover.

## Auxiliary Heat

The heat pump has built in dry contacts **D1-D2**, to activate auxiliary heat. This will most often be electric elements in the buffer tank. **D1-D2** contacts will close with an **adjustable delay after compressor starts**. Use the blue knob on the timer in the electrical box to adjust this delay from 0 to 2 hours.

Devices with their own 24vac transformer and a digital controller (for example, the AltSource tanks available from Maritime Geothermal Ltd. as an accessory) will be directly activated by the **D1-D2** dry contact. Be sure to set up the AltSource tank according to a following page, so that its temperature limiter remains effective. This is necessary because **D1-D2** defaults to ON when the heat pump is off or inoperative, so that backup heat remains in effect.

Devices without their own transformer can have their contactor activated with a 24vac signal through D1-D2, using the wiring on the following page. **Note that some external temperature limiter must remain in effect since D1-D2 defaults to ON when heat pump is OFF.**

Signal	Description
C	24VAC Common (Ground)
R	24VAC Hot
Y <sub>C(EXT)</sub>	Cooling demand from optional external controller
O(EXT)	Cooling mode active, from optional external controller (turns off internal aquastat, must be active for all of cooling season)
D1	Dry contacts to activate auxiliary heat (Contacts closed during compressor operation, but with adjustable 0-2 hour delay)
D2	

## Internal Aquastat Operation



In normal operating mode, the aquastat displays the current buffer tank temperature, and this display is visible from outside the unit with cover on. The value will vary slightly, and will reflect the water temperature wherever the probe is placed, ideally near the top of the buffer tank in a dry well.

To make adjustments, remove the cover of the unit.

- Press the **UP** arrow to check the water setpoint temperature.
- Press the **DOWN** arrow to check the temperature differential. (The heat pump will come on when the water temperature falls below the setpoint by the differential, and will heat the tank back up to the setpoint.)
- To change settings, press and hold the **S** button for 3 seconds. Use the arrow keys to select setting F1-F6 (see below table). Press **S** to display current value. To change that value, press and hold **S** while simultaneously pressing an arrow key. Press to save the setting and return to normal display.

Note that when the ON/OFF switch is in the OFF position, or an external cooling controller is connected and active, the internal aquastat display will be inoperative and its display will turn off. Settings will be retained.

Setting	Description
F1	Setpoint temperature (degrees)
F2	Temperature differential (degrees)
F3	Compressor delay time (minutes)
F4	Temperature calibration value (degrees)
F5	°F / °C
F6	High temperature alarm ON/OFF (not used)

HEATING		
	°F	°C
Setpoint	108	42
Differential	10	5
Activation *	98	37
COOLING		
	°F	°C
Setpoint	45	7
Differential (same)	10	5
Activation *	55	12

Heating setpoint should not exceed **120°F (49°C)**; cooling setpoint should not be set below **43°F (6°C)**. Setpoints outside these limits will cause the heat pump operating pressures to approach the safety control settings, possibly causing nuisance shutdowns.

If only pipe-in-concrete floor zones are being heated, it is highly recommended to lower each of the heating setpoints by **10°F (6°C)** for increased efficiency.

## Safety Controls

The heat pump has important built in safety controls which are designed to protect the unit from situations which could damage it if operation falls outside the allowable range.

A control board monitors the safety controls and allows operation of the compressor accordingly. The compressor will not be allowed to start if a 'fault' condition exists.

The control board has an on-board LED which will flash the code of any fault condition. The compressor will be locked out for five minutes when a fault occurs, after which it will be re-enabled if the fault has been cleared. If the fault re-occurs within a 60 minute period, the control board will go into permanent lockout mode. It will stay in permanent lockout with the flashing fault code until the unit is reset by powering down.

The control board also has an ALR pin with a 24VAC output. It energizes when a permanent lockout occurs. An external 24VAC indicator or relay can be connected across ALR and C on the terminal strip if external signaling is desired.

The board has a **TEST** jumper, which removes the 5 minute anti-short cycle timer for test purposes. If left in the TEST position, it will time out and return to normal operation after a set time period. This is to prevent compressor short cycling if the jumper is accidentally left in the TEST position.

TABLE 9 - Control Board Fault Codes	
Fault	LED Flashes
High pressure	1
Low pressure (Loss of Charge / LOC)	2
Indoor loop water coil freezeup / Flow switch	3
Brownout	5
Outdoor loop water coil freezeup	6

### 1. High Pressure

The high/discharge refrigerant pressure safety control monitors the compressor discharge pressure and shuts the compressor down if the condensing pressure becomes too high.

There are several reasons this control would activate in heating mode:

1. Low or no indoor loop flow (although if no flow, flow switch will likely cause code 3 first).
2. High indoor loop entering liquid temperature.
3. Dirty or fouled indoor loop heat exchanger.
2. High refrigerant charge after service, or mechanical malfunction (see [Troubleshooting](#) section).

### 2. Low Pressure

The low/suction refrigerant pressure control monitors the compressor suction pressure and will shut the compressor down if the refrigerant evaporating pressure becomes very low, indicating possible loss of charge (LOC) due to a **refrigerant leak**.

### 3. Indoor Loop Water Coil Freezeup or No Flow

The FREEZE thermistor measures the temperature of the TXV flash line in cooling mode, which also reflects the temperature of the indoor loop water coil when it is being used as the evaporator (as it is in cooling mode). If it gets too cold, this heat exchanger is in danger of freezing and breaking. This should only occur when the heat pump is in cooling mode and is normally caused by **low indoor loop water flow**. Note that the **FREEZE TEMP** jumper on the control board should always be left at **32F** for this alarm to function properly.

There is a possible second origin for a code 3 alarm: since the indoor loop heat exchanger is a **brazed plate** rather than a

coaxial coil, there is an **indoor loop flow switch** for additional protection against freezing. If this flow switch is open, indicating little no indoor loop flow, alarm 3 will be activated. *This can happen in heating mode or cooling mode.*

### 5. Brownout

The board monitors the voltage of the 24VAC control transformer (which is powering the board). A fault will occur if this drops below 18VAC, indicating an **electricity grid brownout**.

### 6. Outdoor Loop Water Coil Freezeup (Heating Mode Only)

The WATER thermistor measures the temperature of the TXV flash line in heating mode, which also reflects the temperature of the indoor loop water coil (which is connected to the outdoor loop or ground loop) when it is being used as the evaporator (as it is in heating mode). If it gets too cold, the water coil is in danger of freezing. *This is a serious danger since it could lead to coil breakage and water contamination of the refrigeration circuit, leading to destruction of the heat pump.*

Note that the **WATER TEMP** jumper on the control board should always be set correctly by the installer for this alarm to function properly:

- For OPEN LOOP / WATER WELL installations, set at **36F**.
- For CLOSED LOOP / GROUND LOOP installations with antifreeze in the loop, set at **20F**.

There are several reasons this control would activate in heating mode:

1. Low or no outdoor loop flow.
2. Low outdoor loop entering liquid temperature.
3. Dirty or fouled outdoor loop heat exchanger.
4. Low refrigerant charge due to leak, or mechanical malfunction (see [Troubleshooting](#) section).



**WARNING: WHEN WATER TEMP JUMPER IS SET AT 20F, A PROPER LOOP ANTIFREEZE CONCENTRATION IS REQUIRED TO PREVENT FREEZING AND RUPTURING OF THE HEAT EXCHANGER, VOIDING THE WARRANTY.**

## Refrigerant Vent Fan Connections

Since these units are classified as "enhanced tightness refrigerating systems" with refrigerant charge  $m_c < m_1$  for the purposes of UL/CSA 60335-2-40, a unit-mounted refrigerant leak detector is not required.

Therefore, a vent fan connection is not necessary.





## AltSource Tanks: Getting Started

**A full product manual from Thermo2000 is included with the AltSource tank.**

This sheet describes how to set the tank to work in conjunction with **NORDIC** heat pumps that are equipped with **D1-D2** terminals. (Some **W-series** models do not have **D1-D2** terminals; in this case the tank can instead be set up run under its own control with a setpoint lower than that of the heat pump.)

**1.** Put the tank in “Bi-Energy” rather than “Electric” mode, with switch on back of controller.

**2.** Set the tank to “joist heat” mode by holding the **wrench** button to display the °F/°C setting, press again to go to heating types, then toggle to second setting which is a picture of joists. Press wrench button three more times to exit.

(This doesn’t mean that joist heating is being done in the building, it just sets a high temperature limit that works well with R410a heat pumps.)

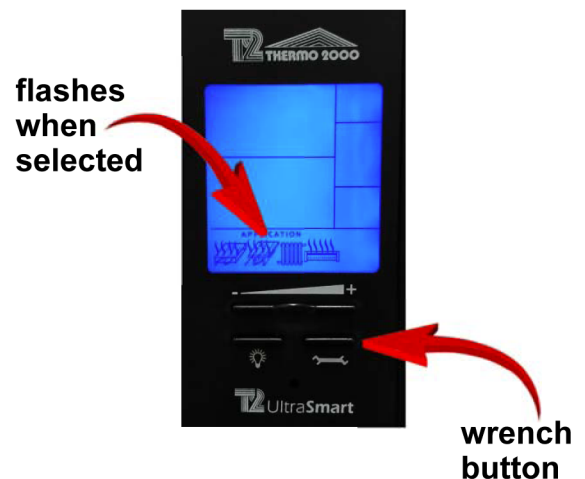

**3.** Connect tank terminals **R** and **W** with a wire jumper.

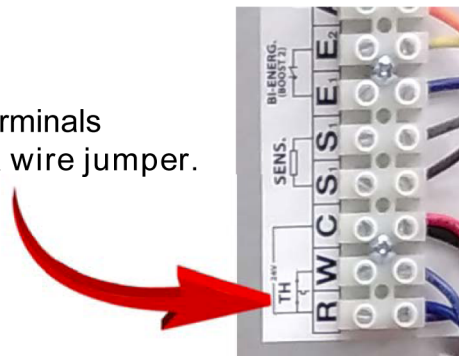

With **R** and **W** connected, a default temperature set-point of **125°F** corresponding to “joist heat” will appear. This is fine for a high limit.



**4.** Now the tank elements will only be activated by a connection between the **E-E** tank terminals, up to the 125°F maximum. This will be done by the **D1-D2** terminals in the heat pump, activating the elements only when **stage 3** or **AUX** heat is required.

See heat pump manual for further explanation.

# Typical Zone and Auxiliary Wiring With GEN2 Setpoint Control (Heating Only)

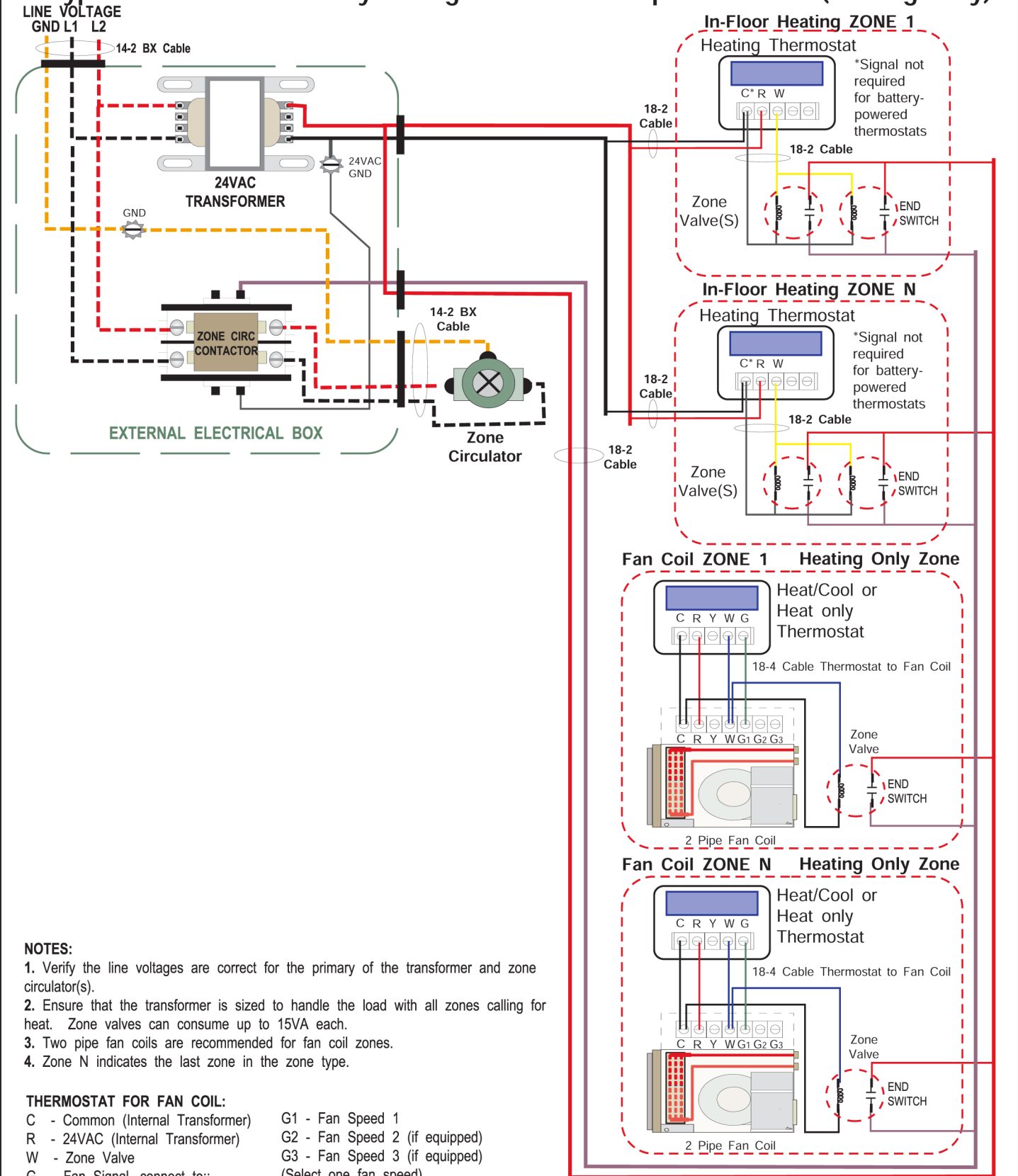

**NOTES:**

1. Verify the line voltages are correct for the primary of the transformer and zone circulator(s).
2. Ensure that the transformer is sized to handle the load with all zones calling for heat. Zone valves can consume up to 15VA each.
3. Two pipe fan coils are recommended for fan coil zones.
4. Zone N indicates the last zone in the zone type.

**THERMOSTAT FOR FAN COIL:**

- |                                   |                                |
|-----------------------------------|--------------------------------|
| C - Common (Internal Transformer) | G1 - Fan Speed 1               |
| R - 24VAC (Internal Transformer)  | G2 - Fan Speed 2 (if equipped) |
| W - Zone Valve                    | G3 - Fan Speed 3 (if equipped) |
| G - Fan Signal, connect to::      | (Select one fan speed)         |

				Drawn By C. Geddes	Date 04-APR-2016	<b>MARITIME GEOTHERMAL LTD.</b>		170 Plantation Rd. Petitcodiac, NB E4Z 6H4			
				Checked By C. Geddes	Date 04-APR-2016						
02	000253	D. RHEAULT	D. RHEAULT	01-JUL-2017	Approved By C. Geddes	(ENG)	Date 04-APR-2016	Drawing Name Typical Zone and Auxiliary Wiring With GEN2 Setpoint Control (Heating Only)			
01	Initial Release	C. GEDDES	C. GEDDES	04-APR-2017	Approved By	(MFG)	Date	Size A	Drawing Number <b>002067CDG</b>	Drawing Rev <b>02</b>	Sheet 1 of 1
REV	ECO #	IMPL BY	APVD BY	DATE	Approved By		Date				

go to TABLE OF CONTENTS

# Typical Control & Zone Wiring w/Internal Aquastat (Heating & Cooling, Automatic Switchover)

**NOTES:**

1. Verify the line voltages are correct for the primary of the transformer and zone circulator(s).
2. Ensure that the transformer is sized to handle the load with all zones calling for heat. Zone valves consume up to 15VA each.
3. Any fan coil that might call for heat when heat pump is in cooling mode must have its own BREAK HEAT RELAY installed, like that shown for the in-floor heating zone.

**THERMOSTAT FOR FAN COIL:**

- C - Common (Internal Transformer) G1 - Fan Speed 1
- R - 24VAC (Internal Transformer) G2 - Fan Speed 2 (if equipped)
- W - Zone Valve G3 - Fan Speed 3 (if equipped)
- G - Fan Signal, connect to: (Select one fan speed)

**IMPORTANT NOTE:**

Zone thermostats must send an "O" signal continuously while set to cooling mode, to avoid repeated heating and cooling of buffer tank on cooling mode demand cycling.

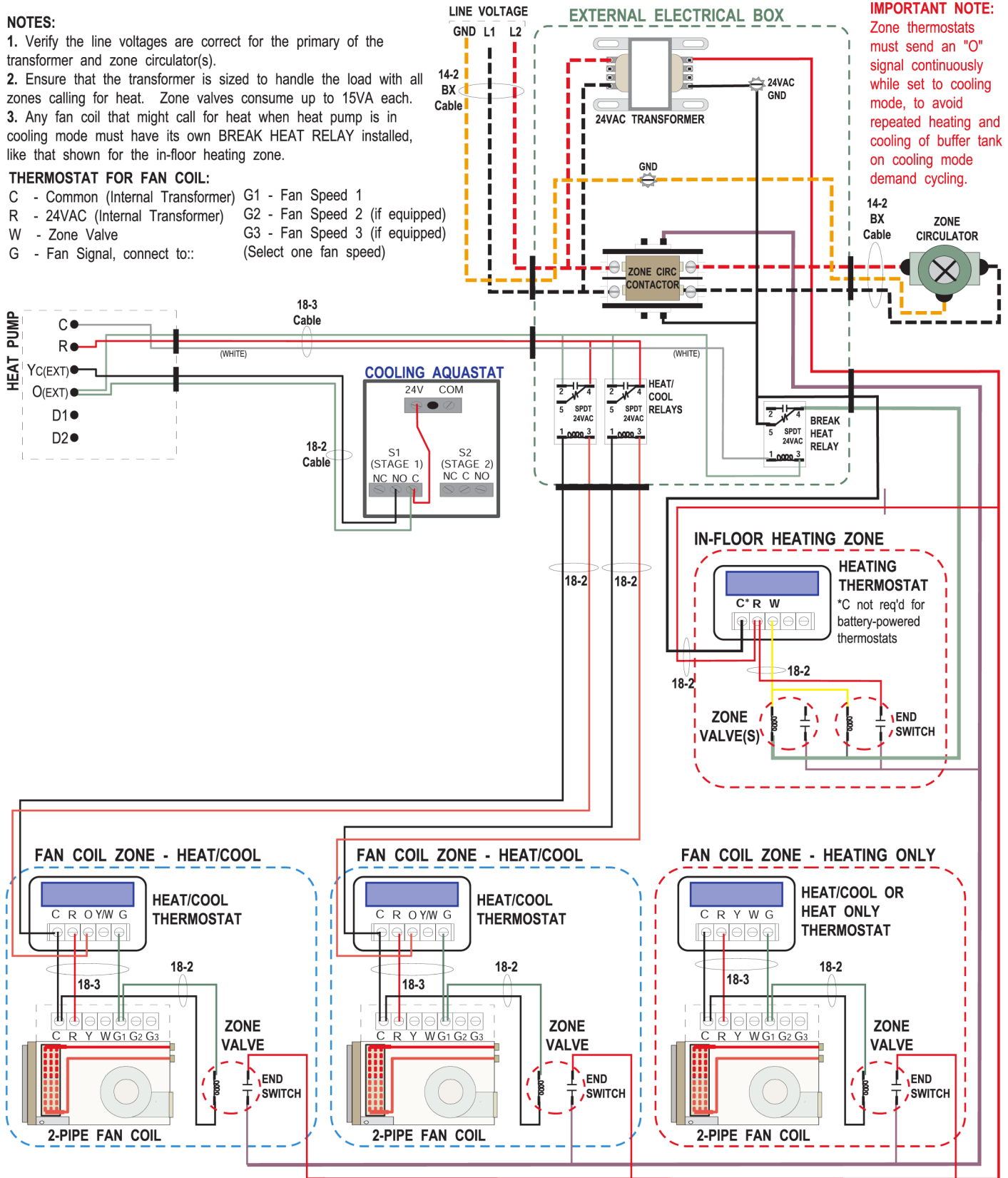

				Drawn By Dan Rheault	Date 24-Mar-2021	<b>MARITIME GEOTHERMAL LTD.</b> 170 Plantation Rd. Petitcodiac, NB E4Z 6H4
				Checked By Dan Rheault	Date 24-Mar-2021	
				Approved By (ENG)	Date	
				Approved By (MFG)	Date	
01	Initial Release	D. RHEAULT	D. RHEAULT	24-Mar-2021		Drawing Name Typical Control and Zone Wiring w/Internal Aquastat (Heating & Cooling, Auto Switchover)
REV	ECO #	IMPL BY	APVD BY	DATE	Approved By	Size A
						Drawing Number <b>002509CDG</b>
						Drawing Rev <b>01</b>
						Sheet 1 of 1

go to TABLE OF CONTENTS

# Piping

## Indoor Loop

The connections for the Indoor Loop circuit are 3/4" brass female NPT. They are labelled as INDOOR IN and INDOOR OUT.

Use of a buffer tank is highly recommended, in order to maintain control over water temperature, and to avoid safety control tripping problems associated with mismatching of heat pump output and zone absorption. It is recommended that a buffer tank with electric elements be selected to provide auxiliary / backup heat.

Typical systems using 4 port and 2 port buffer tanks are shown in the following drawings. They show all of the recommended components as well as where they should be placed, whether using zone valves or zone pumps.

**NOTE:** It is recommended that the water lines between the heat pump and the buffer tank be copper or other high temperature piping.

**NOTE:** Care should be taken when routing the water lines to ensure that adequate access to the heat pump is maintained so as to not compromise serviceability.

The *minimum* buffer tank size should follow the rule of 8 US gallons per ton of heat pump capacity. The following table shows the minimum buffer tank size for each heat pump along with the recommended size. The recommended size will minimize the number of starts per hour and provide longer runtimes for improved efficiency.

TABLE 10 - Buffer Tank Size		
Heat Pump Size	Minimum Size gal (L)	Recommended Size gal (L)
12	10 (40)	30 (115)
18	12 (45)	30 (115)
If a tank size is not available, use the next size larger tank.		

## Outdoor Loop

The connections for the Outdoor Loop circuit are 3/4" brass female NPT. They are labelled as OUTDOOR IN and OUTDOOR OUT.

See the following chapters for details on ground loop and open loop installations.

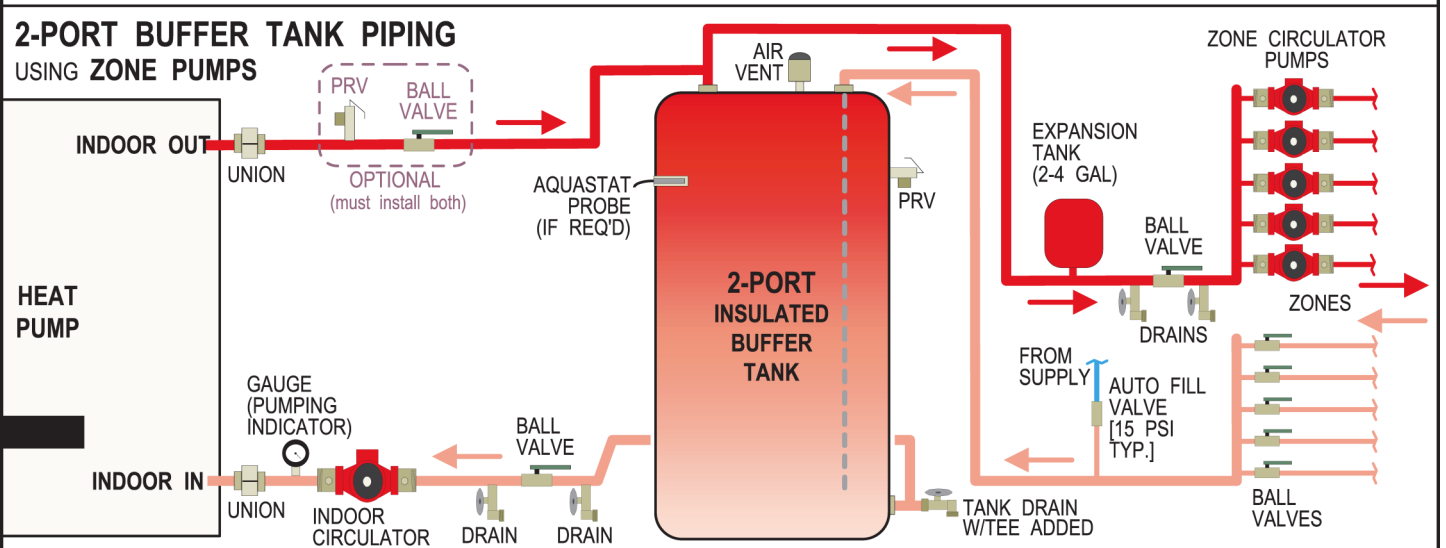
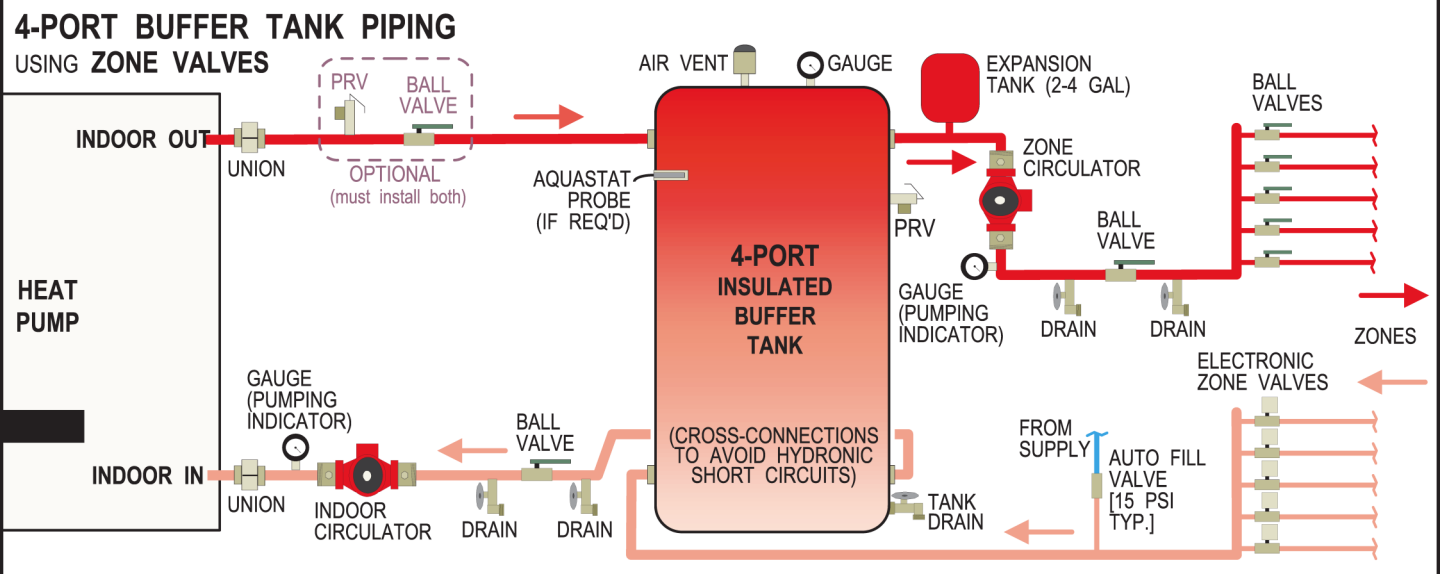
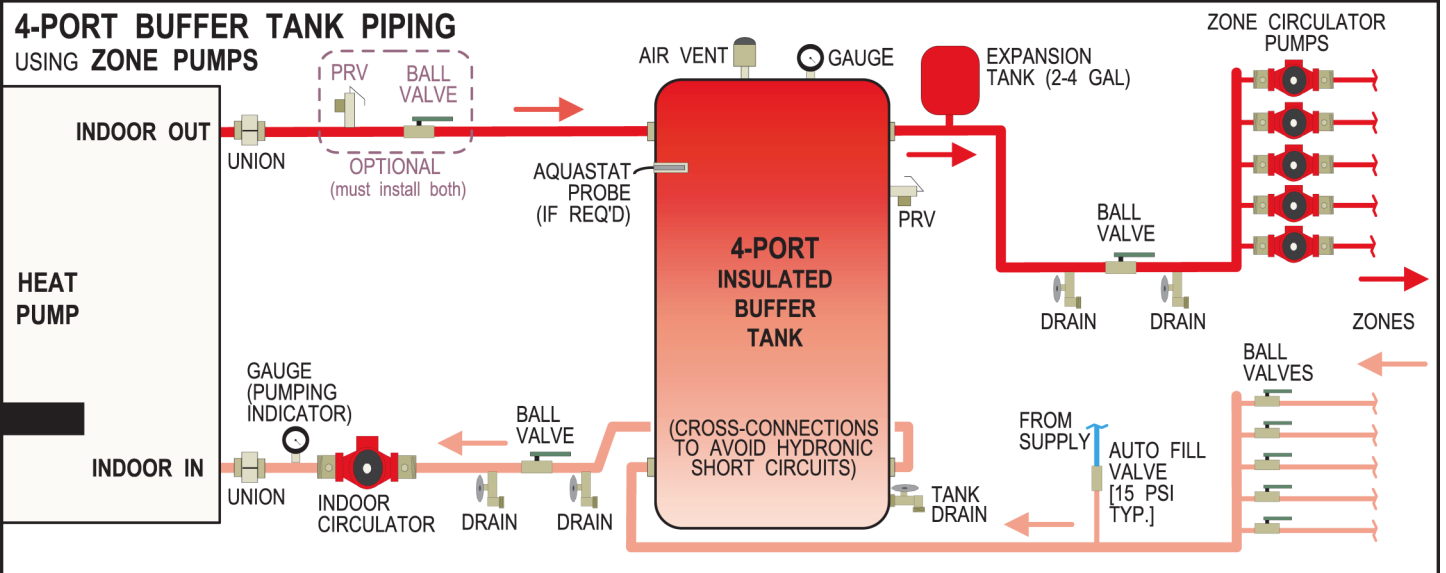

				Drawn By Dan Rheault	Date 14-Dec-2018	<b>MARITIME GEOTHERMAL LTD.</b> 170 Plantation Rd. Petitcodiac, NB E4Z 6H4
				Checked By Dan Rheault	Date 14-Dec-2018	
02	(add fill valve)	D. RHEAULT	D. RHEAULT	Approved By (ENG)	Date 1-Feb-2021	Drawing Name <b>Recommended Hydronic Buffer Tank Piping</b>
01	Initial Release	D. RHEAULT	D. RHEAULT	Approved By (MFG)	Date 14-Dec-2018	
REV	ECO #	IMPL BY	APVD BY	Approved By	Date	
				Size A	Drawing Number <b>002366PDG</b>	REV <b>02</b>
						SHEET 1 of 1

go to TABLE OF CONTENTS

# Auxiliary Boiler Piping

**NOTE:** CHECK VALVES SHOULD BE SPRING TYPE, OTHERWISE UNINTENDED FLOW MAY OCCUR. SIZE CIRCULATORS INCLUDING PRESSURE DROP THROUGH SPRING CHECK VALVES.

SYSTEM WITH 4-PORT TANK & ZONE PUMPS SHOWN; SEE DIAGRAM 002366PDG FOR SYSTEM USING 2-PORT TANK OR ZONE VALVES.

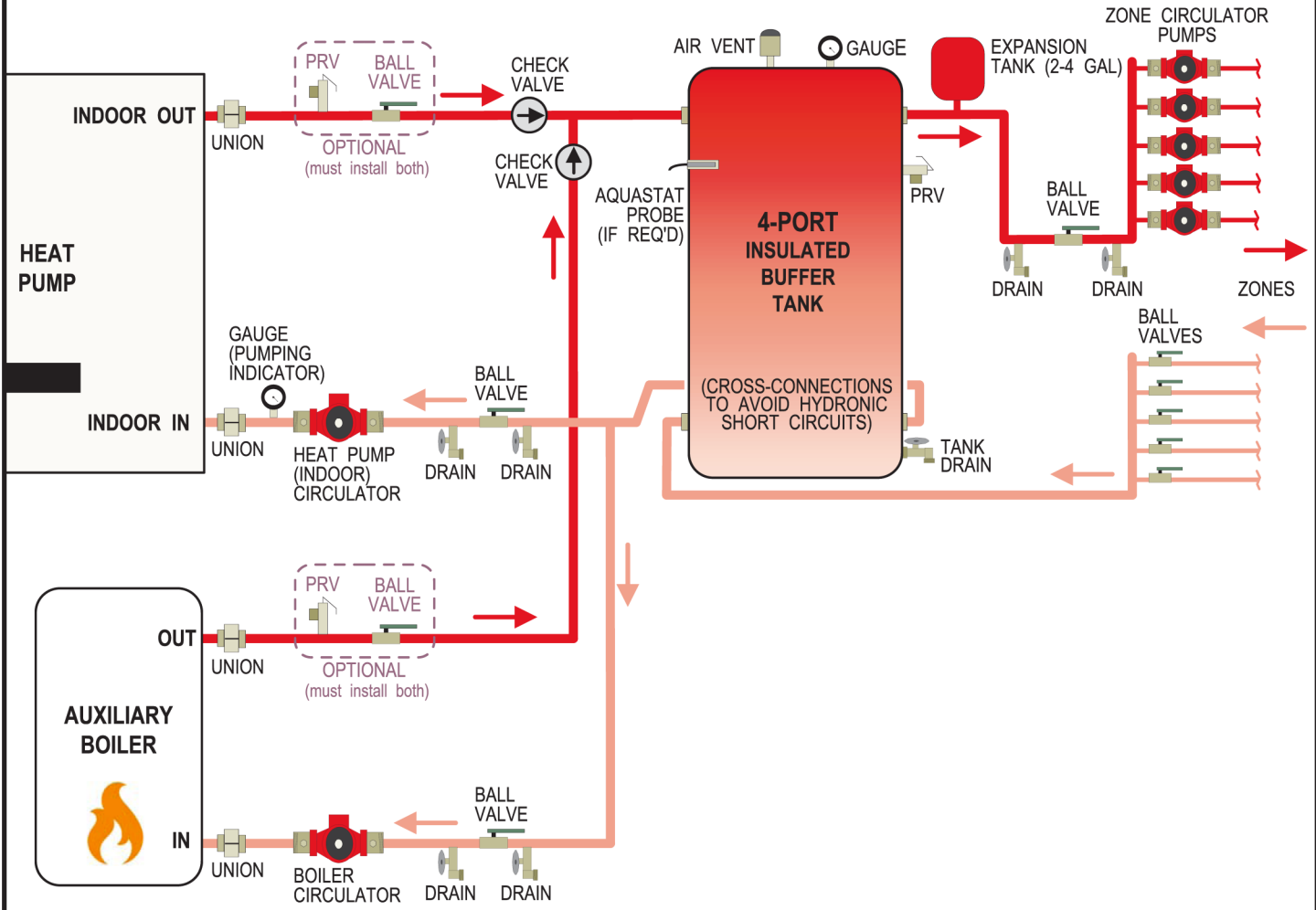

USING THIS PARALLEL ARRANGEMENT, BOILER MAY OPERATE ALONE (TO PROVIDE BACKUP HEAT) OR IN CONJUNCTION WITH HEAT PUMP (TO PROVIDE AUXILIARY HEAT).

BOILER MUST BE CONTROLLED AS 3RD STAGE OF HEAT BY HEAT PUMP CONTROL BOARD OR EXTERNAL CONTROLLER. BOILER MAY THEN OPERATE AT A HIGHER OUTPUT TEMPERATURE THAN HEAT PUMP WITHOUT CAUSING HIGH TEMPERATURE/HIGH PRESSURE PROBLEMS AT THE HEAT PUMP.

				Drawn By Dan Rheault	Date 14-Dec-2018	MARITIME GEOTHERMAL LTD. 170 Plantation Rd. Petitcodiac, NB E4Z 6H4		
				Checked By Dan Rheault	Date 14-Dec-2018			
				Approved By (ENG)	Date	Drawing Name <b>Auxiliary Boiler Piping</b>		
				Approved By (MFG)	Date	Size A	Drawing Number <b>002367PDG</b>	
01	Initial Release	D. RHEAULT	D. RHEAULT	14-Dec-2018	Approved By	Date	REV <b>01</b>	SHEET 1 of 1
REV	ECO #	IMPL BY	APVD BY	DATE	Approved By	Date		

go to TABLE OF CONTENTS

# Two Tank System Piping with a Reversing Heat Pump

## HEATING MODE

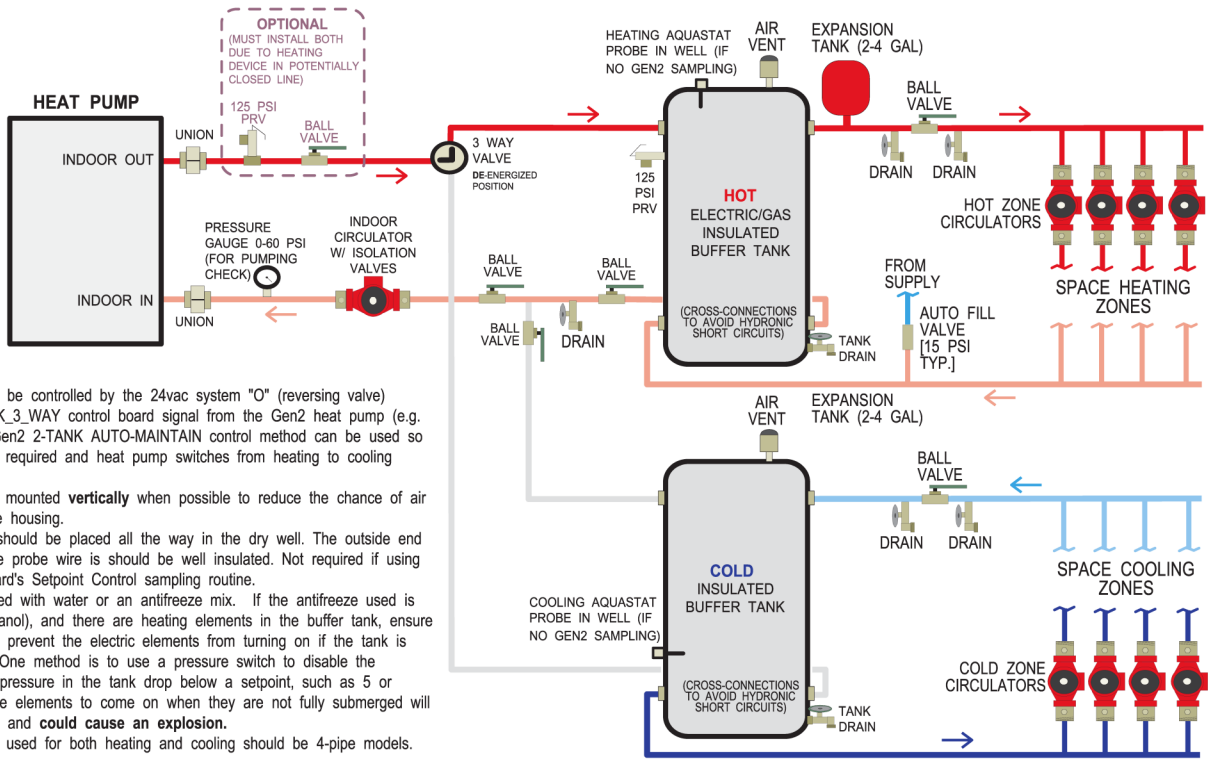

**NOTES:**

1. The 3-way valve can be controlled by the 24vac system "O" (reversing valve) signal, or TWO\_TANK\_3\_WAY control board signal from the Gen2 heat pump (e.g. ATW-Series). The Gen2 2-TANK AUTO-MAINTAIN control method can be used so that no "O" signal is required and heat pump switches from heating to cooling automatically.
2. Circulators should be mounted **vertically** when possible to reduce the chance of air getting trapped in the housing.
3. The aquastat probe should be placed all the way in the dry well. The outside end of the well where the probe wire is should be well insulated. Not required if using the Gen2 control board's Setpoint Control sampling routine.
4. The loop may be filled with water or an antifreeze mix. If the antifreeze used is flammable (e.g. methanol), and there are heating elements in the buffer tank, ensure there is a method to prevent the electric elements from turning on if the tank is not completely full. One method is to use a pressure switch to disable the elements should the pressure in the tank drop below a setpoint, such as 5 or 10PSIG. Allowing the elements to come on when they are not fully submerged will burn the element out and **could cause an explosion.**
5. Hydronic air handlers used for both heating and cooling should be 4-pipe models.

## COOLING MODE

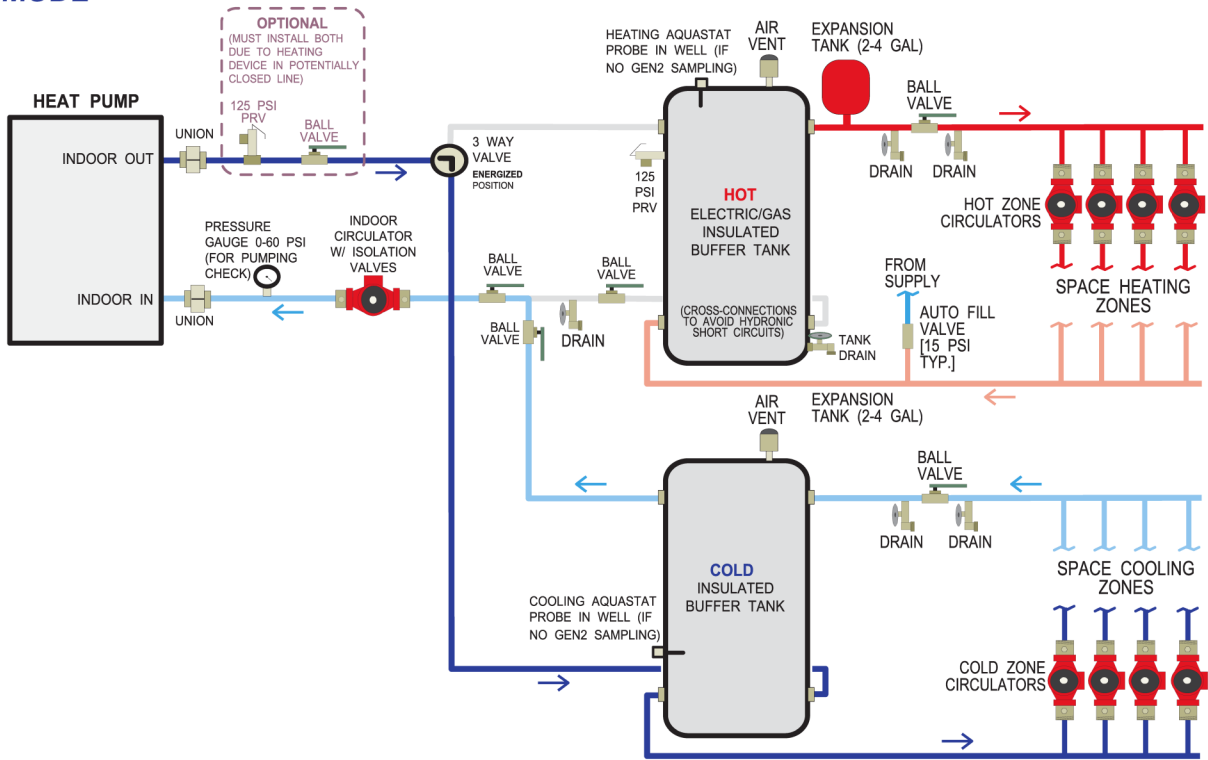

					Drawn By Dan Rheault	Date 25-Oct-2017	MARITIME GEOTHERMAL LTD. 170 Plantation Rd. Petitcodiac, NB E4Z 6H4
02	-	D. RHEAULT	D. RHEAULT	6-Aug-2021	Checked By Dan Rheault	Date 25-Oct-2017	
02	-	D. RHEAULT	D. RHEAULT	1-Mar-2018	Approved By Dan Rheault	Date 25-Oct-2017	
01	Initial Release	D. RHEAULT	D. RHEAULT	25-Oct-2017	Approved By (MFG)	Date	Drawing Name Two Tank System Piping with a Reversing Heat Pump
REV	ECO #	IMPL BY	APVD BY	DATE	Approved By	Date	Size A
							Drawing Number 002252PDG
							REV 03
							SHEET 1 of 1

go to TABLE OF CONTENTS

# Two Tank Simultaneous Heating / Cooling

Non-reversing water-to-water heat pumps move heat from cold tank to hot tank. Simultaneous loads with use both sides of heat pumps, effectively doubling the COP.

Heat pump(s) are activated when cold tank temperature exceeds setpoint, or when hot tank temperature falls below setpoint.

When heating and cooling loads are not balanced, the hot tank will get too hot (when building cooling load is greater), or the cold tank will get too cold (when building heat load is greater). When this happens, controller will move the 3-way valve to direct flow through that tank and start the appropriate ground loop pump. Ground loop fluid will be circulated through the tank to bring its temperature back into range.

Note that ground loop fluid (with antifreeze) is present everywhere in this system, since there is not the separation between hot and cold sides that exists with a reversing system.

This type of simultaneous setup has the advantages of relatively simple control algorithm and ability to rotate lead heat pump, as opposed to a multiple-heat-pump system that limits tank temperatures by diverting heat pump flow directly to a ground loop.

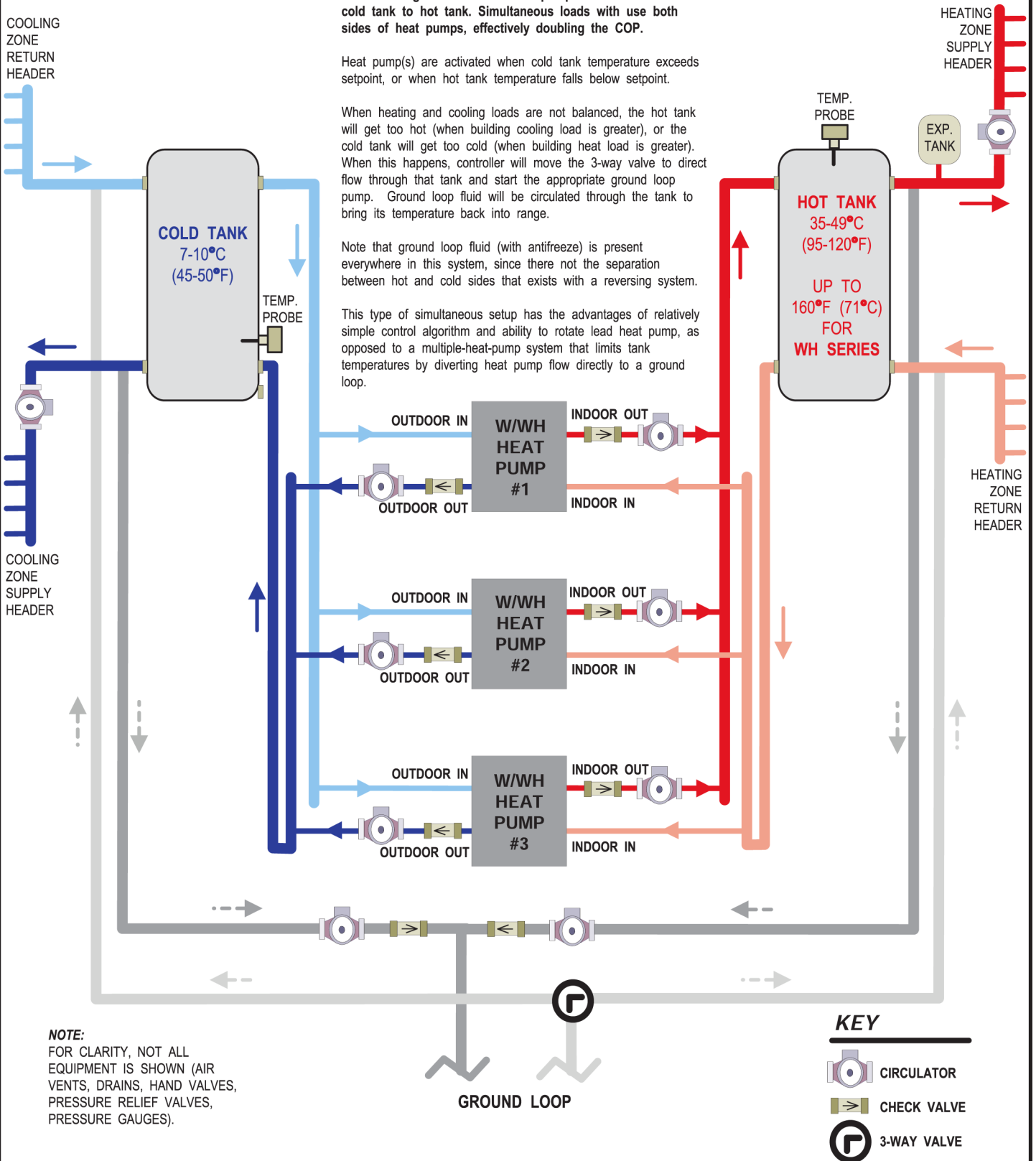

**NOTE:**  
FOR CLARITY, NOT ALL EQUIPMENT IS SHOWN (AIR VENTS, DRAINS, HAND VALVES, PRESSURE RELIEF VALVES, PRESSURE GAUGES).

**KEY**

- CIRCULATOR
- CHECK VALVE
- 3-WAY VALVE

					Drawn By Dan Rheault	Date 2-Mar-2018	<b>MARITIME GEOTHERMAL LTD.</b>	170 Plantation Rd Petitcodiac, NB E4Z 6H4			
					Checked By Dan Rheault	Date 2-Mar-2018		Drawing Name <b>Two Tank Simultaneous Heating / Cooling</b>			
					Approved By (ENG)	Date	Size A		Drawing Number <b>002288PDG</b>	REV <b>01</b>	SHEET 1 of 1
01	Initial Release	D. RHEAULT	D. RHEAULT	2-Mar-2018	Approved By (MFG)	Date					
REV	ECO #	IMPL BY	APVD BY	DATE	Approved By	Date					

go to TABLE OF CONTENTS



# Ground Loop Installations

Refer to diagrams [000608INF](#) & [000609INF](#) at the end of this section for typical ground loop configurations. They are for reference only, and should not be used to replace formal training and computerized loop design.

Once the ground loop has been pressure tested and the header pipes have been connected to the circulator pump module, the heat pump can be connected to the circulator pump module.

## Circulator Pump Module

Maritime Geothermal Ltd. offers compact pump modules with built in three way valves to facilitate filling and purging the ground loop. Refer to drawing [000906CDG](#) at the end of this section. Alternatively, Grundfoss Model UPS 26-99 or Taco Model 0011 pumps or other brands with similar pumping capability may be used. The single pump module will typically handle systems up to 3 tons. This is based on a typical parallel system with one circuit per ton.

Calculate the total pressure drop of the ground loop (including headers, indoor piping and heat pump exchanger drop) based on the antifreeze type and concentration at the desired minimum loop temperature. A pump module that can deliver the flow required for the unit at the calculated total pressure drop should be selected. Refer to the [Model Specific Information](#) section for unit flow requirements. Loop pressure drops can be calculated using software such as those mentioned in the Horizontal Ground loops section, or can be calculated in a spreadsheet using the pipe manufacturer's pressure drop tables for pipe diameter and fittings.

The circulator pump module must be connected to the heat pump Outdoor Loop ports with a lineset suitable for the flow required with minimum pressure drop. 1" rubber or plastic lines should be used.

The installation of P/T plugs/ports (pressure / temperature, pronounced "Pete's plugs") is recommended on both the entering and leaving lines at the heat pump. This will allow the installer or homeowner to check water flow through the loop by measuring the pressure difference through the heat exchanger and comparing it to that listed in the [Model Specific Information](#) section. P/T ports, adapters, and gauge adapters and are available as accessories from Maritime Geothermal Ltd..

## Flushing & Purging

Once the groundloop has been installed and all connections are completed between the heat pump, circulator pump module and ground loop, the entire ground loop system should be **pressure tested with air to 100 PSIG** to make sure there are no leaks on any of the inside fittings. Soap all joints and observe that the pressure remains constant for 1 hour.

When satisfied that all connections are leak free, release the air pressure and connect a purge cart (see [Figure 1](#)) to the flushing access ports at the pump module (refer to drawing [000906CDG](#)). A temporary flushing system can alternately be constructed using a 45 gal. barrel and a pump with sufficient volume and head capability to circulate fluid at a **velocity of at least 2 ft/min** through all parts of the loop.

Adjust the circulator pump module valves to connect the purge cart to the ground loop. Begin pumping water through the ground loop, ensuring that the intake of the pump stays submerged at all times by continuously adding water. Water flowing back from the return line should be directed below the water level in the barrel or flush tank to prevent air being mixed with the outgoing water.

Once the lines have been filled and no more air bubbles are appearing in the line, adjust the circulator pump module valves to circulate water through the heat pump using the same technique as described above. When all air is removed reverse the flow of water through the lines by interchanging the flush cart lines and purge again. You will be able to visibly tell when all air is removed.

**Figure 1: Ground Loop Accessories & Tools**

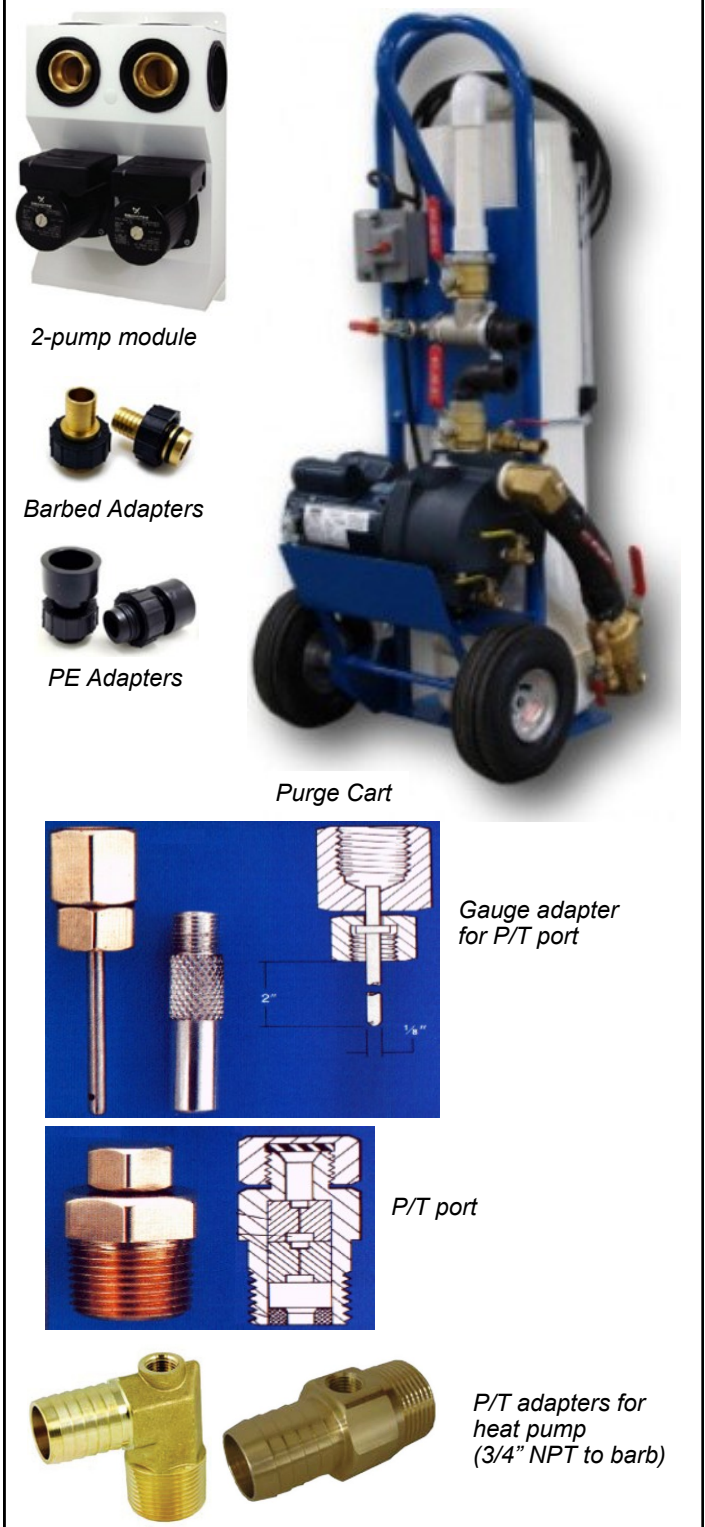

## Adding Antifreeze Solution

In most mid and northern areas of the US and in all of Canada it is necessary to condition the loop fluid by the addition of some type of antifreeze solution so that it will not freeze during operation in the winter months. This antifreeze is required because the loop fluid will normally reach a low entering temperature of **28°F to 32°F (-2°C to 0°C)** and refrigerant temperatures inside the heat pump's heat exchanger may be as low as **20°F (11°C)** cooler. See following table for details of freeze protection provided by different concentrations.

TABLE 11 - Antifreeze Percentages				
BY VOLUME				
Protection to:	10°F	15°F	20°F	25°F
Methanol	25%	21%	16%	10%
Propylene Glycol	38%	30%	22%	15%
BY WEIGHT				
Protection to:	10°F	15°F	20°F	25°F
Methanol	16.8%	13.6%	10%	6.3%
Propylene Glycol	30%	23.5%	18.3%	12.9%



**WARNING: Add enough antifreeze to allow for a temperature 20°F (11°C) lower than the expected lowest loop fluid temperature entering the heat pump. Insufficient antifreeze concentration could cause the heat exchanger to freeze and rupture, voiding the warranty.**

Although many different antifreeze solutions have been employed in geothermal systems, the alcohols such as methanol or ethanol have the most desirable characteristics for groundloop applications. The overall heat transfer characteristics of these fluids remain high although care must be taken when handling pure alcohols since they are extremely flammable. Once mixed in a typical 25% by volume ratio with water the solution is not flammable. In situations where alcohols are not allowed as a loop fluid due to local regulations then propylene glycol is a non-toxic alternative which can be substituted. Propylene glycol should only be used in cases where alcohols are not permitted since the heat transfer characteristics are less desirable and it becomes more viscous at low temperatures, increasing pumping power.

The volume of fluid that your loop system holds can be closely estimated by totaling the number of ft. of each size pipe in the system and referencing the following table for approximate volume per 100 ft.

When the volume of the loop has been calculated and the appropriate amount of antifreeze is ready for addition by referencing the table, drain the equivalent amount of water from the flush cart or mixing barrel and replace it with the antifreeze.

**When using alcohols, be sure to inject below the water line to reduce initial volatility of the pure antifreeze.** If the loop is large it may be necessary to refill the tank with antifreeze several times to get all the antifreeze into the loop. Pump the loop for 5 to 10 minutes longer to ensure the remaining fluid has been well mixed.

## Initial Pressurization

At this point open all valves in the flow circuit and slowly close off the supply and return flush cart valves in a manner that leaves about **20-30 psig.** on the system. If an air bladder expansion tank is used it should be charged to the above

TABLE 12 - Volume of fluid per 100 ft. of pipe				
		Volume /100ft.		
Type of Pipe	Diameter	l.gal	gal	L
Copper	1"	3.4	4.1	15.5
	1-1/4"	5.3	6.4	24.2
	1-1/2"	7.7	9.2	34.8
Rubber Hose	1"	3.2	3.9	14.8
Polyethylene	3/4" IPS SDR11	2.3	2.8	10.6
	1" IPS SDR11	3.7	4.5	17.0
	1-1/4" IPS SDR11	6.7	8.0	30.3
	1-1/2" IPS SDR11	9.1	10.9	41.3
	2" IPS SDR11	15.0	18.0	68.1
Other Item Volumes				
Heat Exchanger	Average	1.2	1.5	5.7
Purge Cart Tank	See cart manual	TBD		

pressure before actual water pressure is put on the system. Systems without an expansion tank will experience greater fluctuations in pressure between the heating and cooling seasons, causing pressure gauges to have different values as the loop temperature changes. This fluctuation is normal since expansion and contraction of the loop fluid must be handled by the elasticity of the plastic loop.

- Pressurize the loop to a static pressure of **45 psig.** when installing a system in the fall going into the heating season.
- Pressurize the loop to a static pressure of **25 psig.** when installing a system in the spring or summer going into the cooling season.

After operating the heat pump for a period of time, any residual air in the system should be bled off and the static pressure should be verified and adjusted if necessary. Add additional water / antifreeze mix with the purge cart to bring the pressure back to the original setting if required.

## Pipe Insulation

All ground loop piping inside the structure (between the structure entry point and the heat pump) should be insulated with 3/8" thick closed cell pipe insulation to prevent condensation and dripping onto floors or walls.

## WATER TEMP Jumper

The purpose of the WATER temperature sensor (thermistor) is prevent heat exchanger freezing in the case of a flow problem.

As mentioned in the **Wiring** chapter, the **WATER TEMP** jumper on the control board should always be set correctly by the installer for this alarm to function properly. For **CLOSED LOOP / GROUND LOOP** installations with antifreeze in the loop, set at **20F.**

This will allow a lower loop temperature than would be appropriate for fresh water before causing a fault.

## TYPICAL HORIZONTAL GROUND LOOP CONFIGURATION

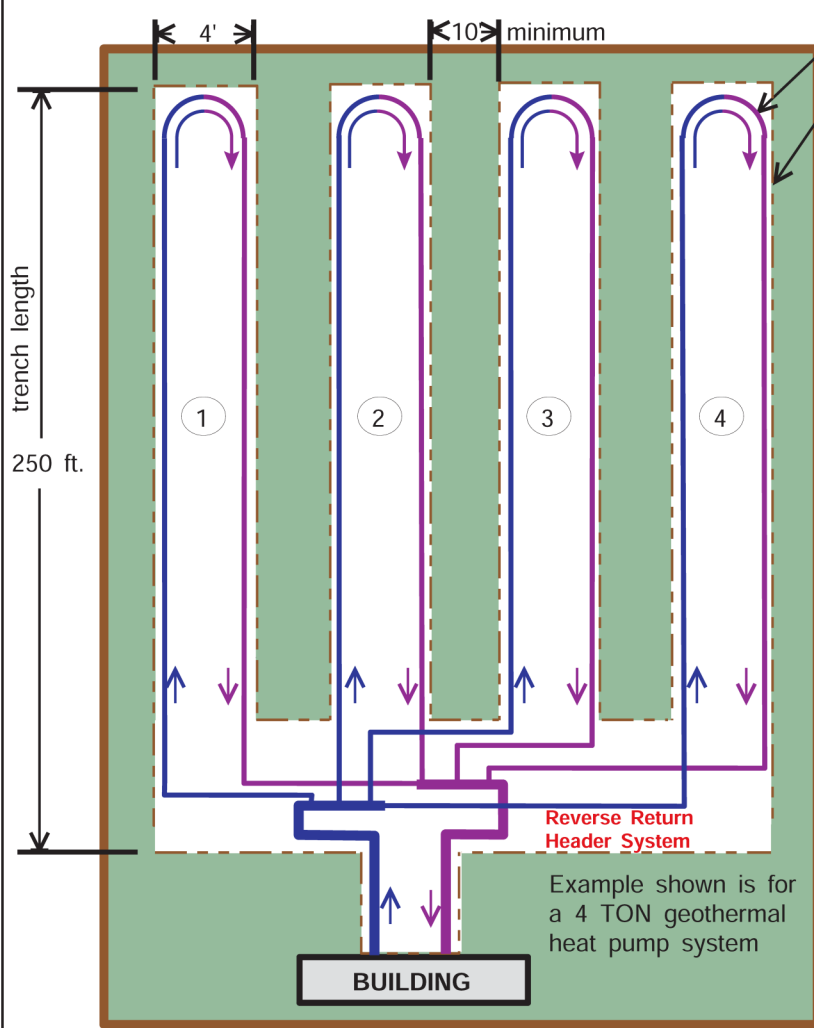

- Type PE 3408 Pipe
- Excavated trenches minimum 4' wide x 6' deep
- Trenches will be backfilled with material which will maximize the thermal conductivity of the adjacent earth.
- Each loop consists of 500ft. of 3/4" type 3408 PE 160 psig (SDR 11) geothermal heat pump polyethylene tubing.
- Each trench is 250ft. beginning from the header. This allows one 500ft. roll of pipe to be used with only two fusion connections (one at each header).
- Allow a minimum of 10 ft. between each trench and preferably 15 - 20 ft. if space is available.
- Insulate all tubing within 12ft. of the structure with 1/2" thick closed cell armaxflex insulation.
- Piping that is laid in a header trench should be insulated to a point where each loop branches to it's individual trench.
- The loop with the most pipe in the header trench could be left uninsulated to pick up heat from the header trench as long as the header trench is more than 12' out from the building.
- Reverse return headers minimize flow imbalances between loops.

Example shown is for a 4 TON geothermal heat pump system

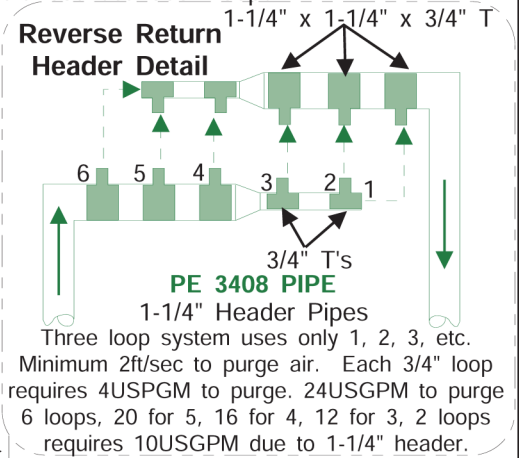

Three loop system uses only 1, 2, 3, etc.  
 Minimum 2ft/sec to purge air. Each 3/4" loop requires 4USGPM to purge. 24USGPM to purge 6 loops, 20 for 5, 16 for 4, 12 for 3, 2 loops requires 10USGPM due to 1-1/4" header.

### Elevation View of Trench

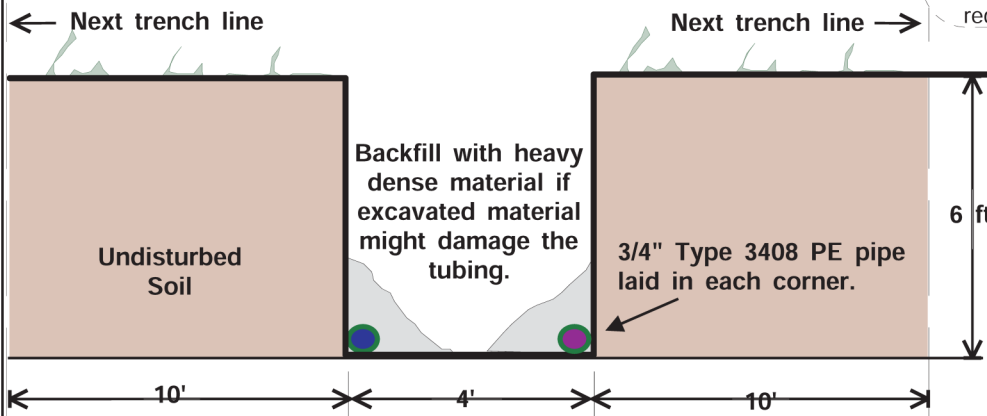

- Hand backfilling in the area just over the plastic pipe is recommended to prevent crushing or pinching of the pipe during backfilling operations.
- Horizontal style pipe runs should be placed 6' deep x minimum of 48" wide trench as shown above, with a minimum of 10ft. between trenches

01	Initial Release	C. GEDDES	C. GEDDES	17 JAN 08	Drawn By Chris Geddes	Date 17 JAN 08	MARITIME GEOTHERMAL LTD. 170 Plantation Rd. Petitcodiac, NB E4Z 6H4
REV	ECO #	IMPL BY	APVD BY	DATE	Checked By Chris Geddes	Date 17 JAN 08	
					Approved By Chris Geddes (ENG)	Date 17 JAN 08	Drawing Name
					Approved By (MFG)	Date	Typical Horizontal Ground Loop Configuration
					Approved By	Date	Size A
							Drawing Number <b>000608INF</b>
							REV <b>01</b>
							SHEET 1 of 1

go to TABLE OF CONTENTS

# TYPICAL VERTICAL GROUND LOOP CONFIGURATION

**Vertical Layout Example 1**

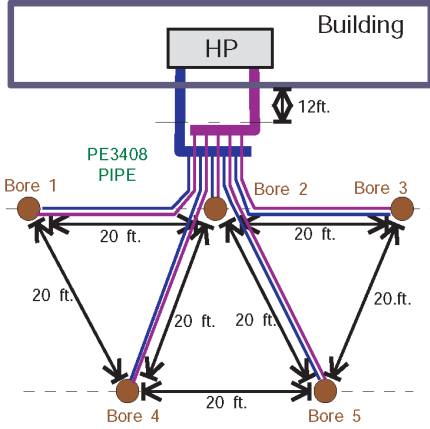

**Vertical Layout Example 2**

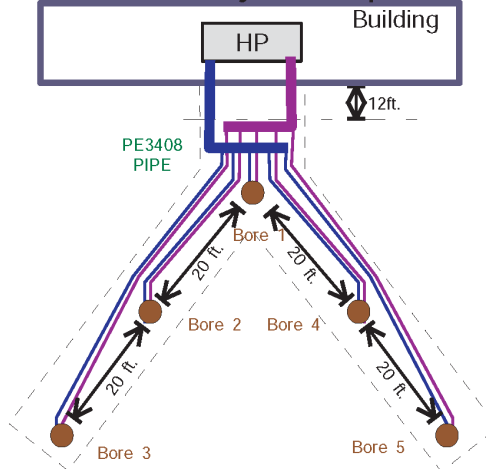

- Examples shown are for a 5 TON geothermal heat pump system
- **Type PE 3408 Pipe**
- Excavated trenches to boreholes minimum 4' wide x 6' deep
- Trenches should be backfilled with material which will maximize the thermal conductivity of the adjacent earth.
- Hand backfilling in the area just over the plastic pipe is recommended to prevent crushing or pinching of the pipe during backfilling operations.
- Allow a minimum of 20 ft. between each borehole for vertical boreholes and 10ft for vertical angled boreholes.
- Piping that is laid in a header trench should be insulated up to the individual trench to the borehole.
- Insulate all tubing within 12ft. of the structure with 1/2" thick closed cell armaflex insulation.
- Reverse return headers minimize flow imbalances between loops.
- The number of boreholes can be reduced by increasing the depth of the boreholes. Care must be taken to size the circulator pump module accordingly.
- Be sure to obtain permission prior to drilling if angled boreholes enter neighbouring properties.

**Angled Vertical Layout Example 1 (can be vertical layout with 20ft spacing)**

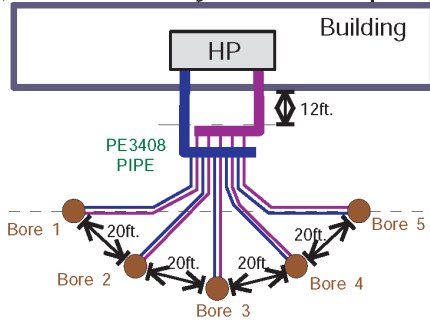

**Reverse Return Header Detail**

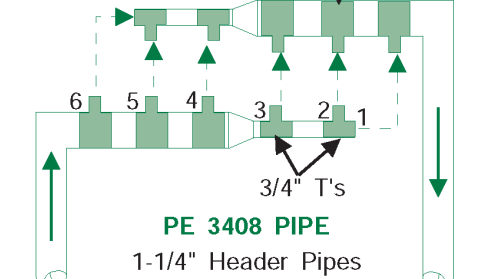

Three loop system uses only 1, 2, 3, etc. Minimum 2ft/sec to purge air. Each 3/4" loop requires 4USGPM to purge. 24USGPM to purge 6 loops, 20 for 5, 16 for 4, 12 for 3, 2 loops requires 10USGPM due to 1-1/4" header.

**Borehole Detail**

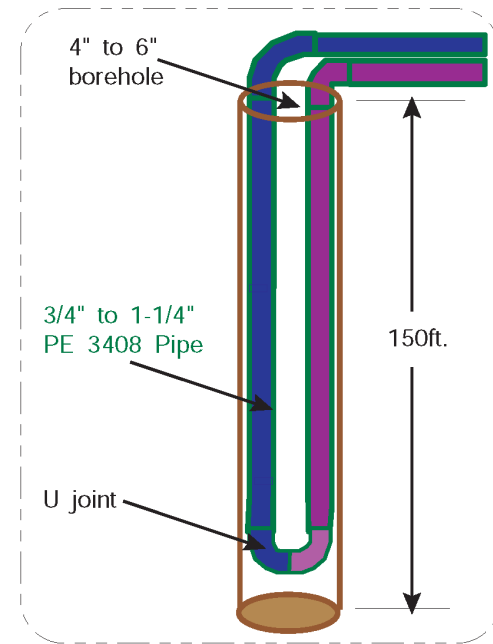

- Each loop consists of minimum 300ft. of 3/4" type 3408 PE 160 psig (SDR 11) geothermal heat pump polyethelene tubing.
- Each borehole is 4-6" diameter and 150ft deep for 1 loop per ton applications.
- Allow enough extra pipe to be able to reach the headers to minimize the number of fusion joints.
- "U" tubes should be taped together every 10ft. A heavy piece of rebar or galvanized pipe can be taped to the last 10ft. to help keep the end straight and also for added weight.
- Fill each "U" tube with water and pressurize to 100PSIG before insertion. The added weight of the water will help with the insertion process
- Tremie grout from the bottom to within 10ft of the top of the borehole. Use neat cement or a mixture of neat cement and bentonite. Check local codes, there may be regulations that must be adhered to.

					Drawn By Chris Geddes	Date 22 JAN 08	MARITIME GEOTHERMAL LTD. 170 Plantation Rd. Petitcodiac, NB E4Z 6H4
					Checked By Chris Geddes	Date 22 JAN 08	
01	ISSUE 02	D. RHEAULT	D. RHEAULT	11 SEP 24	Approved By Chris Geddes (ENG)	Date 22 JAN 08	Drawing Name Typical Vertical Ground Loop Configuration
01	Initial Release	C. GEDDES	C. GEDDES	22 JAN 08	Approved By (MFG)	Date	Size A
REV	ECO #	IMPL BY	APVD BY	DATE	Approved By	Date	Drawing Number <b>000609INF</b>
							REV <b>01</b>
							SHEET 1 of 1

go to TABLE OF CONTENTS



# Geo-Flo Circulator Pump Module Installation - Two Units On One Ground Loop

**NOTE:**

Refer to the heat pump labels for connection locations

Connect wiring to appropriate voltage terminals marked **OUTDOOR CIRCULATORS** in the heat pump electrical box

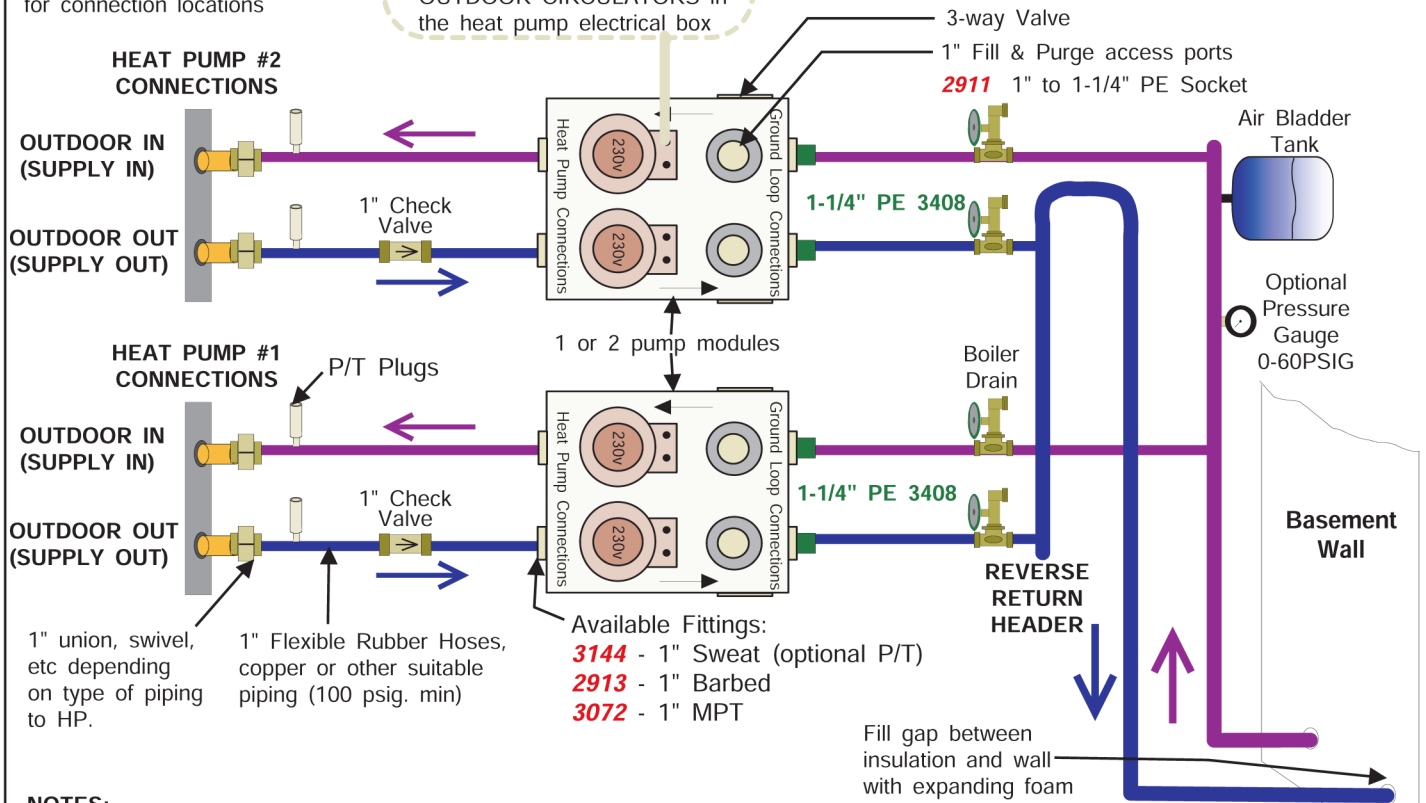

**NOTES:**

- Circulator Pump Module should be mounted vertically to minimize the possibility of air locking the circulators.
- Check valves in the OUT line of each heat pump prevent flow through the heat pump when it is not in operation.
- Ensure that each pump module can provide the required flow to its heat pump when operating solo.
- All lines inside the structure and through the wall should be insulated with 3/8" to 1/2" thick closed cell pipe insulation.
- Holes through the foundation / structure should be filled with expanding foam from both sides to prevent leakage.
- Proper drainage material should be used on the outside of the wall to prevent water buildup.
- Pump module fittings are available from Maritime Geothermal Ltd., Geo-Flo Part Numbers are indicated above (italics).
- A pressure gauge is recommended if P/T plugs are not installed.
- The air bladder tank should be pressurized to the desired static pressure of the ground loop before installation.
- For most applications, a 1 pump module will accommodate NORDIC models sizes 25, 35, and 45, and a 2 pump module will accommodate sizes 55, 65 and 75. The total loop pressure drop including the headers, inside piping and heat exchanger drop should be calculated based on the antifreeze mixture and lowest desired entering water temperature. The pump module selected must provide the required flow at this calculated pressure drop value.

**CIRCULATOR PUMP MODULE 3-WAY VALVE POSITIONS (LEFT SIDE VIEW)**

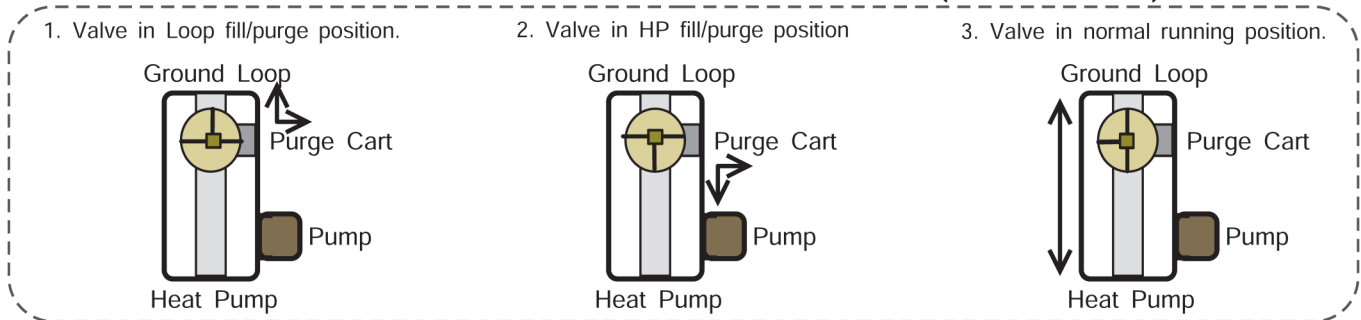

				Drawn By Chris Geddes	Date 21 FEB 08	<b>MARITIME GEOTHERMAL LTD.</b> 170 Plantation Rd. Petticoctiac, NB E4Z 6H4
				Checked By Chris Geddes	Date 21 FEB 08	
				Approved By Chris Geddes (ENG)	Date 21 FEB 08	Drawing Name <b>Geo Flo Circulator Pump Module</b> <b>Installation-Two Units on One Ground Loop</b>
01	Initial Release	C. GEDDES	C. GEDDES	Approved By (MFG)	Date	
REV	ECO #	IMPL BY	APVD BY	DATE	Approved By	Date
					Size A	Drawing Number <b>000629PDG</b>
						REV <b>01</b>
						SHEET <b>1 of 1</b>

go to TABLE OF CONTENTS

# Open Loop Installations

## Well Water Temperature

The temperature of the well water should be a minimum of **41°F (5°C)**, and should normally be **45+°F (7°C+)**. In general, groundwater temperatures across the Canadian prairie provinces and Northern Ontario may be close to the 41°F minimum, while in other parts of southern Canada it will probably be 46-50°F, although local exceptions will exist. In more southern locations, it will be warmer.

The groundwater temperature should be verified as the first step in a proposed open loop installation.

## Well Water Flow

The water source is normally a drilled water well with submersible pump that is the same well which supplies domestic water needs. It must be able to supply the required water flow as listed under the Total Flow column in the table.

**TABLE 13 - Required Flow**

Model Size	Flow* gpm (L/s)	Domestic Water Usage - gpm (L/s)	Total Flow gpm (L/s)
12	3.0 (0.20)	4 (0.25)	7.0 (0.46)
18	4.5 (0.28)	4 (0.25)	8.5 (0.54)

\* These are minimum water requirements based on an entering water temperature of 45° F.

For groundwater temperatures of 50°F or greater, these flows can be reduced by 25% if required.

Rather than being estimated by a well driller, the flow from a proposed source well should be measured by performing an extended flow test to be sure it is capable of supplying the required flow over an extended period of time. This is done by flowing the well at the highest possible rate, noting the static water level in the well, and monitoring the pumping fluid level until stable. Unless the fluid level is very high, fluid level monitoring will require a device called a water level sounder. The flow rate can then be measured either by a cumulative gallon meter, a flowmeter, or by timing the filling of a bucket of known size. The test data can be recorded as follows:

TIME	METER READING (USGAL)	TOTAL FLOW (USGAL)	FLOW RATE (USGPM)	WATER LEVEL (FT) (IN)	WATER LEVEL (FT)	
20:25	131735.5	0		20	6	20.5
20:27	131756	20.5	10.3	24	0	24.0
20:30	131779	23	6.0	26	0	26.0
20:42	131847	68	6.1	29	0	29.0
20:51	131906	59	6.6	29	0	29.0
21:03	131982	76	6.3	29	0	29.0
21:32	132156	174	6.0	29	0	29.0

It is best to flow the well for as long as possible (e.g. 12 hours) at the flow rate required by the proposed heat pump size. However, if the test is performed before a larger submersible pump is installed, it may be assumed that any unused water level drop during the test (that is, any distance remaining between the pumping fluid level and the pump intake) would contribute linearly to the flow rate should a larger pump be installed.

In the above example, it was recorded that the flow rate stabilized at 6 gpm, while the water level dropped from 20 to 29 feet (9 feet). If the intake of a larger pump could be placed so that a further pumping fluid level drop of 9 feet could be

achieved (total 18 feet), it can be assumed that the flow would double to 12 gpm. Of course, this should be verified with a second test once the larger pump is actually installed.

## Well Water Quality

The well water should be tested to be sure it meets minimum standards. Although the threat of poor water quality to open loop installations is often exaggerated, poor water quality can lead to rapid heat exchanger failure or frequent servicing.

First, the well should not produce any sand. Sand will physically erode heat exchanger surfaces, and quickly clog return (injection) wells. Solids or TDS should be less than 1 ppm (1 mg/L) if a return well is used.

To avoid scale formation on the inside of the heat pump's outdoor loop coil, total hardness should be less than 350 ppm / 350 mg/L. In practice, scaling is very rarely a problem at northern groundwater temperatures of 50°F or less because scale does not generally form at low well water temperatures (unlike, for example, in a domestic hot water tank). In more southern climates, the hardness guideline will be a more important consideration. Should scale form, heat pump performance will gradually deteriorate, and will require periodic flushing with a calcium/lime removing solution (see General Maintenance section). If the need for periodic flushing is anticipated, the optional Cupro-Nickel (CuNi) coil and piping should be ordered.

Corrosive (salty) water can cause failure of the inner tube of the heat exchanger, leading to loss of refrigerant and water entering the refrigeration circuit, which ruins the heat pump. If chlorides exceed 20 ppm (20 mg/L), the optional CuNi coil and piping should be ordered. If chlorides exceed 150 ppm (150 mg/L), or significant Ammonia (>0.5 ppm) or H<sub>2</sub>S (>0.2 ppm) is present, the use of an open loop system should be reconsidered.

## Water Discharge Methods

Water disposal methods vary from area to area. However, some consideration should be made to prevent the cooled discharge water from immediately coming in contact with the supply source. Attempting to return the water to the source well will eventually cool the water so much that the heat pump will shut off on its low pressure safety control.

Acceptable methods for disposing of the waste water are listed below. The waste water is clean; the heat pump has no effect other than reducing the temperature of the water. **Refer to drawing 000907INF** for typical disposal method diagrams.

- Second well (return well)
- Percolation (Drain, ditch, leaching field)
- Pond, river or stream

**ENSURE SELECTED METHOD CONFORMS TO LOCAL REGULATIONS.**

A return well should be a minimum of **80 ft.** from the supply well for residential applications. The water returned to the well will not necessarily be pumped into the same aquifer, depending on underground conditions. The return well must be able to supply at least the same quantity of water as the amount you wish to inject into it, preferably much more, since injection capacity will tend to decrease over time due to clogging. It may be necessary to place a pressure-tight cap on the well to keep the return water from flowing out the top of the well. This cap is

**Figure 2: Open Loop Accessories & Tools**

Water Level Sounder



Cumulative Gallon Meter



Motorized Water valve



Rainbird Solenoid

Dole Valve

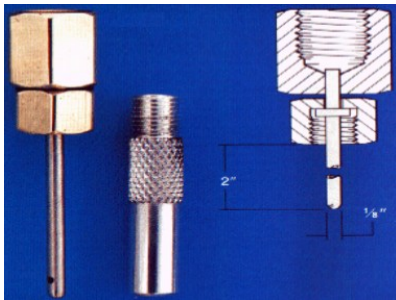
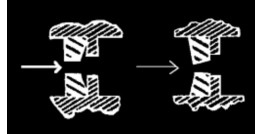

Gauge adapter for P/T port

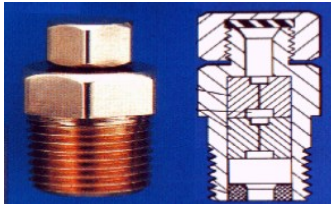

P/T port



P/T adapters for heat pump (1" NPT to barb)

commonly required since a certain amount of pressure may be needed to force the return water back down the well in cases of limited injectivity.

Water discharged by percolation will generally soak into the ground within a distance of 50 to 100 ft. If suitable care is taken to ensure that the drain pipe runs downhill and the end of the pipe is protected by a bale of hay or spruce bows, the end of the pipe will not freeze as the pipe will empty out when the heat pump shuts off and the water valve closes. A screen should be installed on the end of large discharge pipes, to prevent animals from building nests inside during extended 'off' periods and causing a backflooding risk for open water drains.

When snow comes it will usually cover the entire process much like a small spring. It is recommended that the pipe be below the frost line when possible for maximum freeze protection.

When discharging into a river or stream, or above the surface of a pond, the same guidelines should be followed as described in the paragraph above for the percolation method.

When discharging the waste water below the surface of a pond or lake, the discharge pipe should be placed below the frost line to prevent the pipe from freezing. As opposed to the percolation method, water will remain in the end of the pipe. It is recommended that the surface of the pond be lower than the installation location of the heat pump. This reduces the back pressure generated by the weight of the water in the pond.

## Water Valve

Water flow through the heat pump is turned on and off by a water valve, which is controlled by a 24VAC signal from the heat pump. It should be installed on the OUT pipe of the heat pump, so that the heat exchanger remains full of water at all times. There are 3 types of water valves that may be available from Maritime Geothermal.

- **Hailin** or equivalent slow acting **motorized ball valve**, which is always powered with 24VAC from **R** and opened with a **Y** or **Y1** signal.
- **Taco** slow acting **motorized ball valve**, which is powered open and stores the energy required to close using a capacitor.
- **Rainbird** or equivalent fast acting **solenoid valve**.

Most installations use a slow closing motorized ball valve. These take 5-15 seconds to close, so avoid the water hammer which can occur with fast acting valves. A fast acting solenoid valve can be used for applications where water hammer is not expected.

All valves come from Maritime Geothermal Ltd. with a **wiring harness**, which plugs into a connector behind the pipe post of the heat pump. If buying a water valve elsewhere, be sure to get the wiring harness from Maritime Geothermal. This connector is required since there are no terminal strips in these units to wire a valve manually to.

## WATER TEMP Jumper

The purpose of the WATER temperature sensor (thermistor) is prevent well water heat exchanger freezing in the case of a flow problem.

As mentioned in the **Wiring** chapter, the **WATER TEMP** jumper on the control board should always be set correctly by the installer for this alarm to function properly. For OPEN LOOP / WELL WATER installations without antifreeze in the loop, set at **36F**.

This will allow only loop temperatures appropriate for fresh water.

## Water Flow Control

A flow restricting ('Dole' or 'Hays') valve is highly recommended, installed downstream of the water valve. This is a passive (non-electrical) device which automatically varies the size of its rubber orifice in order to restrict flow to its stamped gpm value, regardless of water pressure. This is important in order to provide some backpressure to the water system, which could otherwise be too low for the comfort of people taking showers or otherwise using the domestic water system. It also prevents excessively low refrigerant discharge pressure when in cooling mode. Dole valves are available as an accessory.

Dole valves can emit a 'whistling' sound if the pressure drop through them is high. Therefore, they should be placed where the noise will not cause a nuisance, e.g. outside the basement wall or perhaps in a well insulated box. Hays flow restrictors do not have this drawback.

## Submersible Pump Selection

Of course, the submersible pump must be large enough to supply the flow required by the heat pump. This is usually not a problem, pumps often being oversized by default.

However, if a conventional fixed speed pump is too large, its fixed capacity will exceed that of the Dole valve at reasonable pressure switch settings (<80 psi). This will cause the submersible pump to cycle on and off continuously while the heat pump is running, causing excessive wear to the submersible pump. The installation of a large air bladder tank will cause the cycles to have a longer duration, but will not solve the problem.

To avoid this problem, the fixed speed pump should be sized according to its head vs. flow curve. The required head should be calculated using height between the pumping fluid level in the well and the elevation of the heat pump, pipe pressure drop at nominal flow rate, desired system water pressure, and any back pressure from return well. Then a pump can be selected that delivers the nominal flow for the chosen heat pump size at that head. In case this calculation is not exact, a variety of Dole valves can be carried by the installer, and a larger Dole valve installed if submersible pump cycling is observed.

An alternate approach would be to install a variable speed submersible pump, which varies its speed to maintain a constant water system pressure. Or use a mechanical 'cycle stop' valve, which is installed upstream of the air bladder / pressure tank and varies its orifice to put backpressure on the pump during periods of low flow in order to keep it from cycling off.

## Submersible Pump Power Draw

In an open loop installation, the submersible water pump draws significant power compared to the heat pump, especially for smaller heat pump sizes. This is particularly true when using a conventional fixed speed submersible pump. Under traditional usage, the efficiency of such a pump is not particularly important, due to its short run times in a domestic water system. But when used with a geothermal heat pump, which can run all day on the coldest days of the year, it is highly recommended that effort be made to select an energy efficient submersible pump. However, these may be hard to find.

## Plumbing the Heat Pump

**The port connections for the outdoor loop are brass FPT fittings. They are marked as OUTDOOR IN and OUTDOOR OUT.**

Plumbing lines, both IN (supply) and OUT (discharge), must be of adequate size to handle the water flow necessary for the heat pump. A copper or plastic line should be run to the Outdoor IN (Supply IN) pipe of the heat pump. Similarly, a line should be run from the Outdoor OUT (Supply Out) pipe to the method of disposal. P/T plugs should be installed at each port. See **Figure 1** in the Ground Loop section for a description of P/T plugs. The water valve should be installed in the OUT (discharge) line. Refer to **drawing 000907CDG** at the end of this section for the recommended setup. Placing the water valve in the discharge line ensures that the heat exchanger inside the heat pump remains full of water when the unit is not running. Unions or some other form of disconnect should be used so that the coaxial heat exchanger may be accessed should it required cleaning.

As mentioned earlier, the heat pump has an electrical connector for the water valve just inside the case. After the water valve is installed, run the valve harness into the case through the hole provided. Remove the jumper plug from the valve connector and connect the harness in its place.

Optionally, a water flow meter can be installed in the discharge line so that the exact amount of water flowing can be determined at a glance. It should be placed between the Outdoor OUT (Supply OUT) pipe of the heat pump and the water valve.

With proper flow, there should be **5-7°F (3-4°C)** delta T between the IN and OUT water temperatures of the heat pump when operating in the heating mode.

All water line valves on both the supply and discharge lines should be either BALL or GATE valves. GLOBE valves have a higher pressure drop, meaning more pumping power to maintain the required flow to the heat pump.

## Pipe Insulation

All ground water piping to and from the Outdoor Loop ports on the heat pump should be insulated with 3/8" closed cell pipe insulation, to prevent condensation and dripping onto floors or walls.

## Typical Ground Water Installation for Size 25-80 Heat Pumps for Units With Brass FPT Fittings TACO 24VAC EBV (Electronic Ball Valve)

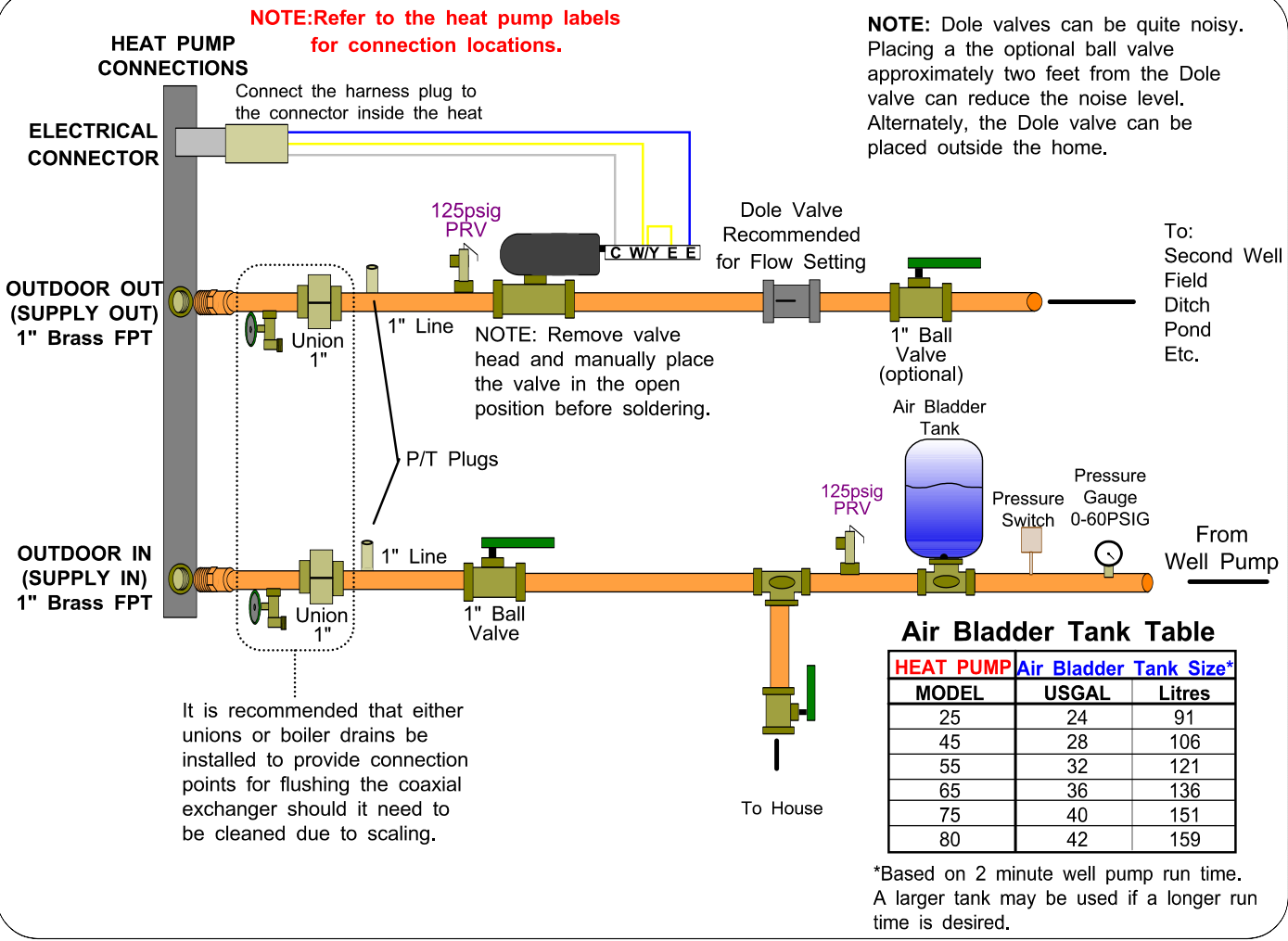

**Air Bladder Tank Table**

HEAT PUMP MODEL	Air Bladder Tank Size* USGAL	Litres
25	24	91
45	28	106
55	32	121
65	36	136
75	40	151
80	42	159

\*Based on 2 minute well pump run time. A larger tank may be used if a longer run time is desired.

### TACO 24VAC Slow Close Water Valve

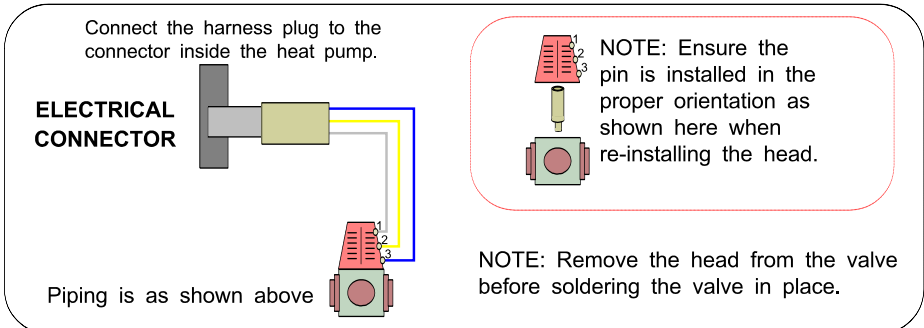

### Generic 24VAC Solenoid Water Valve

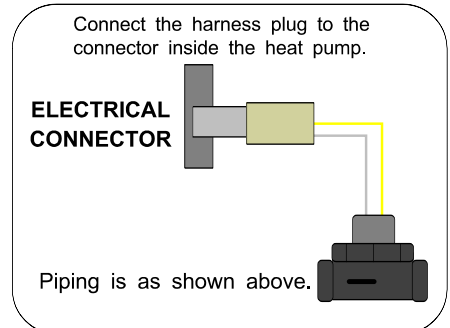

02	000228	C. GEDDES	C. GEDDES	21 MAY 2014	Drawn By Chris Geddes	Date 10 DEC 08	<b>MARITIME GEOTHERMAL LTD.</b>	170 Plantation Rd. Petticoatic, NB E4Z 6H4
01	Initial Release	C. GEDDES	C. GEDDES	10 DEC 08	Checked By Chris Geddes	Date 10 DEC 08		
REV	ECO #	IMPL BY	APVD BY	DATE	Approved By Chris Geddes (ENG)	Date 10 DEC 08	Drawing Name Typical Ground Water Installation for Size 25-80 Heat Pumps (Brass FPT)	
					Approved By (MFG)	Date	Size A	Drawing Number <b>000907CDG</b>
					Approved By	Date	Drawing Rev <b>02</b>	SHEET 1 of 1

go to TABLE OF CONTENTS



# Startup Procedure

---

The W-Series Startup Record located in this manual is used in conjunction with this startup procedure to provide a detailed record of the installation. A completed copy should be left on site and a copy kept on file by the installer.

***A copy of the detailed startup record no longer needs to be sent to Maritime Geothermal Ltd.  
Instead, submit the brief warranty registration form found on last page of this manual and printed copy included with unit.***

## Pre-Start Inspection

### Heat Pump:

1. Verify WATER TEMP jumper on control board is set properly for open or closed loop as per [Wiring](#) chapter.

### Indoor Loop (Hydronic Loop):

1. Verify that all shutoff valves are fully open and there are no restrictions in the piping from the heat pump to the indoor loop, and that full flow is available to the heat pump.
2. Verify that the entire system has been flooded and all the air has been purged as much as possible. Further purging may be required after the system has been operating for a while.
3. Verify that the loop contains the proper mix of antifreeze (if used) for the intended application. If applicable, record the type of antifreeze and the mixture value on the startup sheet, circle % Vol. or % Weight.
4. Record the static loop pressure on the startup sheet.

### Outdoor Loop (Ground Loop):

1. Verify that all shutoff valves are fully open and there are no restrictions in the piping from the heat pump to the ground loop, and that full flow is available to the heat pump.
2. Verify that the entire system has been flooded and all the air has been purged as much as possible. Further purging may be required after the system has been operating for a while.
3. Verify that the loop contains the proper mix of antifreeze for the intended application. Record the type of antifreeze and the mixture value on the startup sheet; circle % Vol. or % Weight.
4. Record the static loop pressure on the startup sheet.

### Outdoor Loop (Open Loop):

1. Verify there are no leaks in the connections to the unit. Verify the water valve is installed and properly oriented in the water out line.
2. Verify that there is flow control in water out line.

### Electrical:

1. **Ensure the power to the unit is off.**
2. Verify all high voltage connections. Ensure that there are no stray wire strands, all connections are tight and the ground wire is connected tightly to the ground connector.
3. Record the fuse / circuit breaker size and wire gauge for the heat pump.
4. Verify that the control connections to the unit are properly connected and all control signals are off, so that the unit will not start up when the power is turned on.
5. Verify that the circulator pumps are connected to the proper voltage terminals in the heat pump. Record the voltages of the circulator pumps.
6. Ensure all access panels except the one that provides access to the electrical box are in place.

## Unit Startup

The unit is now ready to be started. The steps below outline the procedure for starting the unit and verifying proper operation of the unit controlled by internal aquastat and possibly an external cooling aquastat. **It is recommended that safety glasses be worn during the following procedures.**

### Preparation:

1. Remove the caps from the service ports and connect a refrigeration manifold set to the unit.
2. Turn the power on to the heat pump and set the all controls to OFF.
3. Measure the following voltages on the compressor contactor and record them on the startup sheet: L1-L2, L2-L3, L1-L3.

### Heating Mode:

1. Set the internal aquastat setpoint to 110°F to activate compressor. The compressor will start (allow 30-60 seconds for the water valve to open for ground water systems) as well as the circulator pumps.
2. Check the refrigeration gauges. The suction and discharge pressures will depend on the loop temperatures, but they should be about **90-110PSIG** and **260-360PSIG** respectively for a typical start-up.
3. Monitor the refrigeration gauges while the unit runs. Record the following after 10 minutes of runtime:
  1. Suction pressure
  2. Discharge pressure
  3. Indoor Loop In (Hot In) temperature
  4. Indoor Loop Out (Hot Out) temperature
  5. Indoor Delta T (should be between **8-12°F, 4-6°C**)
  6. Outdoor Loop In (Supply In) temperature
  7. Outdoor Loop Out (Supply Out) temperature
  8. Outdoor Delta T (should be between **5-8°F, 3-4°C**)
  9. Outdoor flow (if available)
  10. Compressor L1(C) current (black wire, place meter between electrical box and compressor)
4. Adjust the aquastat setpoint to the desired buffer tank temperature and let the unit run through a cycle. Record the setpoint and the discharge pressure when the unit shuts off.

### Cooling Mode:

1. Adjust internal aquastat setpoint to 50°F (10 °C) to activate cooling mode.
2. Monitor the refrigeration gauges while the unit runs. Record the following after 10 minutes of runtime:
  1. Suction pressure
  2. Discharge pressure
  3. Indoor Loop In (Hot In) temperature
  4. Indoor Loop Out (Hot Out) temperature
  5. Indoor Delta T
  6. Outdoor Loop In (Supply In) temperature
  7. Outdoor Loop Out (Supply Out) temperature
  8. Outdoor Delta T
3. Adjust the cooling aquastat setpoints to the desired tank temperature, and allow the unit to run through a cycle. Record the aquastat setpoint and the suction pressure when the unit shuts off.

### Final Inspection:

1. Turn the power off to the unit and remove all test equipment.
2. Install the electrical box cover and the access panel on the heat pump. Install the service port caps securely to prevent refrigerant loss.
3. Do a final check for leaks in the ground water / ground loop system and ensure the area is clean.
4. Turn the power on to the unit. Set the aquastat(s) to the final settings and record the values.

**Startup Record: W-12 to 18** *A copy of this detailed startup record no longer needs to be sent to Maritime Geothermal Ltd.. Instead, submit the brief warranty registration form (last page of manual & printed copy with unit).*

<b>Installation Site</b>		<b>Startup Date</b>	<b>Installer</b>	
<b>City</b>			<b>Company</b>	
<b>Province</b>		<b>Check boxes unless asked to record data. Circle data units.</b>	<b>Model</b>	
<b>Country</b>			<b>Serial #</b>	
<b>Homeowner Name</b>		<b>Homeowner Phone #</b>		

**PRE-START INSPECTION**



<b>Indoor Loop (Hydronic)</b>	All shut-off valve are open (full flow available)					
	Loop is full and purged of air					
	Antifreeze type					
	Antifreeze concentration			% Volume	% Weight	
	Loop static pressure			PSI	kPa	
<b>Ground Loop System</b>	WATER TEMP jumper on control board is set at <b>20F</b> .					
	All shut-off valve are open (full flow available)					
	Loop is full and purged of air					
	Antifreeze type					
	Antifreeze concentration			% Volume	% Weight	
	Loop static pressure			PSI	kPa	
<b>Ground Water System</b>	WATER TEMP jumper on control board is set at <b>36F</b> .					
	Water valve installed in return line					
	Flow control installed in return line					
<b>Electrical</b>	High voltage connections are correct and securely fastened					
	Circuit breaker (or fuse) size and wire gauge for Heat Pump		A		Ga.	
	Circulator pump voltages (Outdoor 1, Outdoor 2, Indoor 1)		V		V	V
	Low voltage connections are correct and securely fastened					

**STARTUP DATA**

<b>Preparation</b>	Voltage across L1 and L2, L1 and L3, L2 and L3						VA
<b>Heating Mode (10 minutes)</b>	Suction Pressure / Discharge Pressure					psig	kPa
	Indoor In (Hot In), Indoor Out (Hot Out), and Delta T		In		Out		°F °C
	Outdoor In (Supply In), Outdoor Out (Supply Out), and Delta T		In		Out		°F °C
	Outdoor Flow		lgpm	USgpm	L/s		
	Compressor L1 (black wire) current		A				
	Aquastat setpoint and discharge pressure at cycle end		°F	°C		psig	kPa
<b>Cooling Mode (10 minutes)</b>	Suction Pressure / Discharge Pressure					psig	kPa
	Indoor In (Hot In), Indoor Out (Hot Out), and Delta T		In		Out		°F °C
	Outdoor In (Supply In), Outdoor Out (Supply Out), and Delta T		In		Out		°F °C
	Cooling aquastat setpoint and suction pressure at cycle end		°F	°C		psig	kPa
<b>Final Aquastat Settings</b>	Heating S1 Setpoint, S1 Delta, S2 Setpoint, S2 Delta					°F	°C
	Cooling S1 Setpoint, S1 Delta, S2 Setpoint, S2 Delta					°F	°C

<b>Date:</b>		<b>Startup Personnel Signature:</b>		<b>Site Personnel Signature:</b>	
--------------	--	-------------------------------------	--	----------------------------------	--

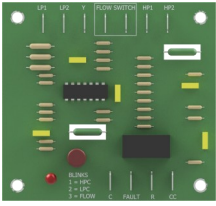
# Routine Maintenance

MAINTENANCE SCHEDULE		
Item	Interval	Procedure
<b>Compressor Contactor</b> 	1 year	Inspect for pitted or burned points. Replace if necessary.
<b>Control Board</b> 	When heat pump problem is suspected	Check status light for faults. Rectify problem if alarms found. See <a href="#">Troubleshooting</a> chapter.
<b>Heat Exchangers</b> 	When experiencing performance degradation that is not explained by a refrigeration circuit problem or low loop flow rate	Disconnect the loop and flush heat exchanger with a calcium removing solution. Generally not required for closed loop or cold water open loop systems or indoor loops; whenever system performance is reduced for warm water open loop systems. See instructions below.

## Coaxial Heat Exchanger Flushing Procedure - Open Loop

1. Isolate the heat exchanger by closing the valves in the IN and OUT ports to the heat exchanger.
2. Blow out the heat exchanger into a clean 5 gallon bucket using compressed air.
3. If a purge cart is not available, use a 5 gallon plastic bucket, a circulator and some plastic piping to create a make-shift pump system. Connect a the inlet and outlet to the heat exchanger ports.
4. Place 2 gallons of RYDLYME or similar in the purge cart (or bucket). Circulate the fluid through the heat exchanger for at least 2 hours (3 hours recommended).
5. Disconnect the purge system and dispose of the solution. RYDLYME is non-toxic and biodegradable and as such can be poured down a drain.
6. Connect fresh water and a drain to the heat exchanger ports and flush the exchanger for several minutes.
7. Return the plumbing to its original configuration and open the IN and OUT valves. Operate the system and check for improved performance.

## Coaxial Heat Exchanger Flushing Procedure - Closed Ground Loop

1. Isolate the heat exchanger by placing the pump module valves in the exchanger flushing position.
2. Connect a compressed air and a drain pipe to the pump module purge ports and blow the anti-freeze solution into a clean 5 gallon bucket.
3. Connect a purge cart to the pump module purge ports.
4. Place 2 gallons of RYDLYME or similar in the purge cart. Circulate the fluid through the heat exchanger for at least 2 hours (3 hours recommended).
5. Disconnect the purge cart and dispose of the solution. RYDLYME is non-toxic and biodegradable and as such can be poured down a drain. Clean the purge cart thoroughly.
6. Connect fresh water and a drain to the pump module purge ports and flush the exchanger for several minutes.
7. Blow the heat exchanger out with compressed air as per STEP 2 and dump the water down a drain.
8. Connect the purge cart to the pump module purge ports. Re-fill and purge the heat exchanger with as per standard procedures (the antifreeze from STEP 2 can be re-used).
9. Disconnect the purge cart and set the pump module valves back to the original positions. Operate the system and check for improved performance.

# Troubleshooting Guide

The following steps are for troubleshooting the heat pump. Repair procedures and reference refrigeration circuit diagrams can be found later in this manual.

- STEP 1:** Turn on the ON/OFF switch and verify that the display is present on the internal aquastat. If it is not present, proceed to POWER SUPPLY TROUBLE SHOOTING, otherwise proceed to STEP 2.
- STEP 2:** Remove the door and electrical box cover and check to see if there is a fault code on the control board. If there is, record the fault code. Turn the power off, wait 10 seconds and turn the power back on. Set the aquastat and/or room thermostats to call for heating or cooling depending on the season.
- STEP 3:** If a 24VAC signal does not appear across Y on the control board and C of the terminal strip after 5 minutes, proceed to the INTERNAL AQUASTAT TROUBLESHOOTING section, otherwise proceed to STEP 4.
- STEP 4:** If a fault code appears once a signal is present at Y on the control board and the compressor does not attempt to start, proceed to the FAULT CODE TROUBLESHOOTING section, otherwise proceed to STEP 5.
- STEP 5:** If no fault codes appear and the compressor does not attempt to start, attempts to start but cannot, starts hard, or starts but does not sound normal, proceed to the COMPRESSOR TROUBLESHOOTING section, otherwise proceed to STEP 6.
- STEP 6:** If the compressor starts and sounds normal, this means the compressor is OK and the problem lies elsewhere. Proceed to the OPERATION TROUBLESHOOTING section.
- NOTE:** To speed up the troubleshooting process, the TEST jumper on the safety board can be placed to the YES position to change the anti-short cycle timer to 5 seconds. **Be sure to set it back to NO when servicing is complete.**

POWER SUPPLY TROUBLESHOOTING			
Fault	Possible Cause	Verification	Recommended Action
No power to the heat pump	Disconnect switch open (if installed)	Verify disconnect switch is in the ON position.	Determine why the disconnect switch was opened, if all is OK close the switch.
	Fuse blown / breaker tripped	At heat pump disconnect box, voltmeter shows 230VAC on the line side but not on the load side.	Reset breaker or replace fuse with proper size and type. (Time-delay type "D")
No display on internal aquastat	ON/OFF switch is OFF.	Examine the switch on left side of cabinet. "1"=ON, "0"=OFF.	Turn on switch.
	Transformer impedance protection tripped or faulty transformer	230VAC is present across L1 and L3 of the compressor contactor but 24VAC is not present across R and C of the terminal strip.	Replace transformer.
	Faulty aquastat.	24VAC is present across 24V and COM of the aquastat but there is no display.	Replace aquastat.

INTERNAL AQUASTAT TROUBLESHOOTING			
Fault	Possible Cause	Verification	Recommended Action
No Y signal to heat pump control board	Incorrect internal aquastat setup.	Internal aquastat does not indicate a red dot beside HEAT or COOL on its display.	Correct the setpoint or setup.
	Open loop water valve end switch (if present) is not closing.	Examine water valve as it is activated by the aquastat signal to be sure it is fully opening and end switch is working.	Replace water valve.
	Faulty internal aquastat.	No 24VAC between Control board Y and C on terminal strip when HEAT or COOL is indicated on the aquastat display.	Replace internal aquastat.
Setting(s) not retained	Faulty internal aquastat.	Setpoint is reset by power on/off.	Replace aquastat.

FAULT CODE TROUBLESHOOTING			
Fault	Possible Cause	Verification	Recommended Action
<b>Fault Code 1 (High Pressure Control)</b>	High operating refrigerant pressure	Using a refrigeration gauge set, verify that high pressure approaches or exceeds 565psi with compressor on.	See "High Discharge Pressure" in Heating Mode / Cooling Mode Troubleshooting section.
	Faulty High Pressure Control, failed open ( <b>very unlikely</b> ) * For this test there must be a signal present on Y, but compressor should not be running (disconnect compressor wires)	Verify that there is 24VAC across HPS (right terminal) on the control board and C of the terminal strip, as well as HPS (left terminal) and C.	Replace high pressure control if voltage is present on one terminal but not the other.
	Faulty control board ( <b>very unlikely</b> )	24VAC is present across HPS (right terminal) and C of the terminal strip, as well as HPS (left terminal) and C, but is not present across CC on the control board and C after 10 minutes.	Replace control board.
<b>Fault Code 2 (Low Pressure Control)</b>	Low operating refrigerant pressure	Using a refrigeration gauge set, verify that low pressure approaches or dips below 35psi with compressor on.	In practice, it is unlikely that a low pressure fault will occur only when compressor is started, since the WATER or FREEZE temperature faults would occur first; unless problem is LOC—>
	Little or no refrigerant in unit (LOC / Loss of Charge)	With compressor off, use a refrigeration gauge set to check refrigeration pressure of the unit for a very low value (less than 35 psi).	Locate the leak and repair it. Spray 9, a sniffer, and dye are common methods of locating a leak.
	Faulty low pressure control, failed open ( <b>very unlikely</b> ) * For this test there must be a signal present on Y, but compressor should not be running (disconnect compressor wires)	Verify if there is 24VAC across LPS on the control board and C of the terminal strip, as well as HPS (left terminal) and C.	Replace high pressure control if voltage is present on one terminal but not the other.
	Faulty control board ( <b>very unlikely</b> )	24VAC is present across LPS and C of the terminal strip, as well as HPS (left terminal) and C, but is not present across CC on the control board and C after 10 minutes.	Replace control board.

FAULT CODE TROUBLESHOOTING continued			
Fault	Possible Cause	Verification	Recommended Action
<b>Fault Code 3 (Indoor Loop Brazed Plate Heat Exchanger Freezeup OR Flow Switch)</b>	FREEZE jumper on control board is set incorrectly.	FREEZE jumper should always be set at <b>32F</b> .	Correct if at a different position.
	Low operating refrigerant suction pressure in <b>cooling</b> mode.	With unit running in cooling mode, monitor suction pressure with a refrigeration gauge set. It falls to 75 psi or lower when fault occurs.	See “Low Suction Pressure” in Cooling Mode Troubleshooting section.
	Faulty FREEZE thermistor, likely with pink/purple wire, located on pipe between filter-dryer and brazed plate heat exchanger ( <b>unlikely</b> ) * For this test, compressor must be running	With unit running in cooling mode, monitor suction pressure with a refrigeration gauge set. If it does not fall to 75 psi or lower when fault occurs, FREEZE thermistor may be faulty.	Check FREEZE thermistor is securely attached and check wire connections. Rectify any problems found. If no problems found, replace thermistor.
	Faulty control board ( <b>very unlikely</b> )	This fault occurs in heating mode, or replacing FREEZE thermistor in above step doesn’t fix problem.	Replace control board.
	Flow switch is tripped (not activated). <b>Can happen in heating or cooling modes.</b>	Manually activate indoor loop circ pump with a jumper between R on terminal strip and pin 3 of the indoor circ relay (see SCH diagram in <b>Model Specific Information</b> chapter). Unplug the female disconnects from the two FREEZE connections on board and measure resistance between the unplugged wires. If there is infinite resistance (no connection), flow switch is not activated.	Investigate why there is no flow (circ pump seized, not powered, or air locked?)
<b>Fault Code 5 (Brownout)</b>	Low voltage from the electrical grid	Verify that the electrical supply has dropped below ~165VAC, causing transformer voltage to drop below 18VAC.	Contact electrical utility or wait for regular service to be restored.
<b>Fault Code 6 (Outdoor Loop Water Coil Freezeup)</b>	WATER jumper on control board is set incorrectly.	WATER jumper should be set at: <b>36F</b> for open loop <b>20F</b> for closed loop.	Correct if at a different position.
	Low operating refrigerant suction pressure in <b>heating</b> mode.	With unit running in heating mode, monitor suction pressure with a refrigeration gauge set. It falls to 75 psi or lower (open loop) or 55 psi or lower (closed loop) when fault occurs.	See “Low Suction Pressure” in Heating Mode Troubleshooting section.
	Faulty WATER thermistor, likely with grey wire, located on pipe between TXV and coaxial water coil ( <b>unlikely</b> ) * For this test, compressor must be running	With unit running in heating mode, monitor suction pressure with a refrigeration gauge set. If it does not fall to 75 psi or lower (open loop) or 55 psi or lower (closed loop) when fault occurs, WATER thermistor may be faulty.	Check WATER thermistor is securely attached and check wire connections. Rectify any problems found. If no problems found, replace thermistor.
	Faulty control board ( <b>very unlikely</b> )	This fault occurs in cooling mode, or replacing WATER thermistor in above step doesn’t fix problem.	Replace control board.

<b>COMPRESSOR TROUBLESHOOTING</b>			
<b>Fault</b>	<b>Possible Cause</b>	<b>Verification</b>	<b>Recommended Action</b>
<b>Compressor will not start</b>	Faulty control board	Measuring from C on the terminal strip, verify there is voltage at Y, HPS left & right terminals, and LPS; but no voltage present at CC.	Replace control board.
	Faulty run capacitor	Check value with capacitance meter. Should match label on capacitor. Compressor will hum while trying to start and then trip its overload.	Replace if faulty.
	Loose or faulty wiring	Check all compressor wiring, including inside compressor electrical box.	Fix any loose connections. Replace any damaged wires.
	Faulty compressor contactor	Voltage on line side with contactor held closed, but no voltage on one or both terminals on the load side. Points pitted or burned. Or, 24VAC across coil but contactor will not engage.	Replace contactor.
	Thermal overload on compressor tripped	Ohmmeter shows reading when placed across R and S terminals and infinity between C & R or C & S. A valid resistance reading is present again after the compressor has cooled down.	Proceed to Operation Troubleshooting (particularly <i>high suction pressure</i> and <i>high discharge pressure</i> ) to determine the cause of the thermal overload trip.
	Burned out motor (open winding)	Remove wires from compressor. Ohmmeter shows infinite resistance between any two terminals. Note: Be sure compressor overload has had a chance to reset. If compressor is hot this may take several hours.	Replace the compressor.
	Burned out motor (shorted windings)	Remove wires from compressor. Resistance between any two terminals is below the specified value.	Replace the compressor.
	Motor shorted to ground	Remove wires from compressor. Check for infinite resistance between each terminal and ground.	If any terminal to ground is not infinite replace the compressor.
Seized compressor due to locked or damaged mechanism	Compressor attempts to start but trips its internal overload after a few seconds. (Run capacitor already verified)	Attempt to "rock" compressor free. If normal operation cannot be established, replace compressor.	
<b>Compressor starts hard</b>	Compressor is "tight" due to damaged mechanism	Compressor attempts to start but trips its internal overload after a few seconds. Run capacitor has been verified already.	Attempt to "rock" compressor free. If normal operation cannot be established, replace compressor.

**OPERATION TROUBLESHOOTING - HEATING MODE**

Fault	Possible Cause	Verification	Recommended Action
<b>High Discharge Pressure</b>	Aquastat set too high	Verify internal aquastat setting.	Lower setting to recommended max. value of <b>120°F (49°C)</b> .
	Low or no indoor loop flow	Delta T across the indoor loop ports should be 8-12°F (3-6°C), or compare pressure drop to the tables for the unit.	Verify pump is working and sized correctly. Check for restrictions in the circuit, e.g. valve partially closed.
	TXV adjusted too far closed	Verify superheat. It should be between 8-12°F (3-6°C). Superheat will be high if TXV is closed too far.	Adjust TXV to obtain 8-12°F (3-6°C) superheat.
	TXV stuck almost closed or partially blocked by foreign object	Adjusting the TXV does not affect the superheat or the suction pressure.	Adjust the TXV all the way in and out a few times to loosen it. Replace TXV if this does not work.
	Filter-dryer plugged	Feel each end of the filter-dryer; they should be the same temperature. If there is a temperature difference then it is plugged. Also causes low suction pressure.	Replace filter-dryer.
	Unit is overcharged. (Only possible if unit has been field serviced and incorrectly charged.)	High subcooling, low delta T across indoor water coil.	Remove 1/2lb of refrigerant at a time and verify that the discharge pressure reduces. Or remove charge and weigh back in the amount listed on nameplate.
<b>Low Suction Pressure (Low temperature at WATER thermistor)</b>	Low or no outdoor loop liquid flow	Delta T across the Outdoor Loop ports should be 5-7°F (3-4°C), or compare pressure drop to the tables for the unit.	Determine the cause of the flow restriction and correct it. Verify pumps are working and sized correctly for ground loop systems. Verify pump and water valve are working for open loop systems.
	Entering liquid temperature too cold	Measure the entering liquid temperature to see if it is less than ~25F.	Increase the size of the ground loop.
	Dirty or fouled coaxial heat exchanger (more likely for open loop, unlikely for ground loop)	Disconnect the water lines and check the inside of the pipes for scale deposits.	Backflush the coaxial exchanger with a calcium-removing cleaning solution.
	Indoor loop entering liquid temperature too cold	Measure temperature. Should be above 60°F (15°C).	Restrict Indoor liquid flow temporarily until buffer tank comes up to temperature.
	TXV stuck almost closed or partially blocked by foreign object.	Adjusting the TXV does not affect the superheat or the suction pressure. TXV may be frosting up.	Adjust the TXV all the way in and out a few times to loosen it. Replace TXV if this does not work.
	Low refrigerant charge.	Entering liquid temperature, flow and entering air temperature are good but suction is low. Check static refrigeration pressure of the unit for a very low value. Weigh refrigerant out and compare to charge listed on nameplate.	Locate the leak and repair it. Spray 9, a sniffer, and dye are common methods of locating a leak.
<b>High Suction Pressure (may appear to not be pumping)</b>	Faulty compressor, not pumping ( <b>unlikely</b> )	Pressures change only slightly from static values when compressor is started.	Replace compressor.

**OPERATION TROUBLESHOOTING - HEATING MODE** continued

Fault	Possible Cause	Verification	Recommended Action
<b>High Suction Pressure (may appear to not be pumping)</b>	Leaking reversing valve (can cause compressor to overheat and trip internal overload)	Reversing valve is the same temperature on both ends of body, common suction line is warm, compressor is running hot, low compressor discharge pressure.	Tap reversing valve, and switch it back and forth between heating and cooling positions. If this does not work for a long term fix, replace reversing valve.
	TXV adjusted too far open.	Verify superheat. It should be between 8-12°F (3-6°C). Superheat will be low if TXV is open too far.	Adjust TXV to obtain 8-12°F (3-6°C) superheat.
	TXV stuck open	Adjusting the TXV does not affect the superheat or the suction pressure. Low superheat and discharge pressure.	Adjust the TXV all the way in and out a few times to loosen it. Replace TXV if this does not work.
<b>Compressor frosting up</b>	See Low Suction Pressure in this section		
<b>TXV frosting up</b>	TXV stuck almost closed or partially blocked by foreign object	Adjusting the TXV does not affect the superheat or the suction pressure.	Attempt to adjust the TXV all the way out and all the way in a few times to loosen it. Replace TXV if this does not work.
<b>Random high pressure trip (does not occur while on site)</b>	Faulty compressor contactor	Points pitted or burned. Contactor sometimes sticks causing the compressor to run when it shouldn't, tripping the high pressure control.	Replace contactor.
	Intermittent indoor circulator	Verify wiring is good.	Correct the wiring or replace the circulator.

**OPERATION TROUBLESHOOTING - COOLING MODE**

Fault	Possible Cause	Verification	Recommended Action
<b>Heating instead of cooling</b>	Control wiring not set up properly.	Verify that there is 24VAC across Y <sub>C(EXT)</sub> and C of the terminal strip when calling for cooling.	Correct control wiring.
	Faulty reversing valve solenoid coil.	Verify solenoid by removing it from the shaft while the unit is running. There should be a loud "whoosh" sound when it is removed.	Replace solenoid if faulty.
	Faulty reversing valve.	A click can be heard when the coil is energized but the unit continues to heat instead of cool.	Replace reversing valve.
<b>High Discharge pressure</b>	Low or no outdoor loop liquid flow	Delta T across the Outdoor Loop ports should be 8-12°F (4-7°C), or compare pressure drop to the tables for the unit.	Determine the cause of the flow restriction and correct it. Verify pumps are working for ground loop systems. Verify well pump and water valve is working for ground water systems.
	Entering liquid temperature too warm.	Most likely caused by undersized ground loop.	Verify the ground loop sizing. Increase the size of the ground loop if undersized.
	Dirty or fouled coaxial heat exchanger (more likely for open loop, unlikely for ground loop)	Disconnect the water lines and check the inside of the pipes for scale deposits.	Backflush the coaxial exchanger with a calcium-removing cleaning solution.

go to TABLE OF CONTENTS

<b>OPERATION TROUBLESHOOTING - COOLING MODE</b> continued			
<b>Fault</b>	<b>Possible Cause</b>	<b>Verification</b>	<b>Recommended Action</b>
<b>High Discharge pressure</b>	Unit is overcharged (only possible if unit has been field serviced and incorrectly charged)	High subcooling, low delta T across water coil.	Remove 1/2lb of refrigerant at a time and verify that the discharge pressure reduces. Or remove charge and weigh back in the amount listed on nameplate.
<b>High Suction Pressure (may appear to not be pumping)</b>	TXV adjusted too far open	Verify superheat. It should be between 8-12°F (3-6°C). Superheat will be low if TXV is open too far.	Adjust TXV to obtain 8-12°F (3-6°C) superheat.
	TXV stuck open	Adjusting the TXV does not affect the superheat or the suction pressure. Low super heat and discharge pressure.	Adjust the TXV all the way in and out a few times to loosen it. Replace TXV if this does not work.
	Leaking reversing valve (can cause compressor to overheat and trip internal overload)	Reversing valve is the same temperature on both ends of body, common suction line is warm, compressor is running hot, low compressor discharge pressure.	Replace reversing valve.
	Faulty compressor, not pumping ( <b>unlikely</b> )	Pressures change only slightly from static values when compressor is started.	Replace compressor.
<b>Low Suction Pressure (Low temperature at FREEZE thermistor)</b>	Aquastat set too low	Verify aquastat setting.	Raise aquastat setting to recommended value of <b>45°F (7°C)</b>
	Low or no indoor loop flow	Delta T across the Indoor Loop ports should be 5-7°F (3-4°C), or compare pressure drop to the tables for the unit.	Verify pump is working and sized correctly. Check for restrictions in the circuit, e.g. valve partially closed.
	TXV stuck almost closed or partially blocked by foreign object	Adjusting the TXV does not affect the superheat or the suction pressure. TXV may be frosting up.	Adjust the TXV all the way in and out a few times to loosen it. Replace TXV if this does not work.
	Low or no refrigerant charge	Entering water temperature and flow are good but suction is low. Check static refrigeration pressure of the unit for a very low value. Weigh refrigerant out and compare to charge listed on nameplate.	Locate the leak and repair it. Spray 9, a sniffer, and dye are common methods of locating a leak.
<b>Compressor frosting up</b>	See Low Suction Pressure in this section.		
<b>TXV frosting up</b>	TXV stuck almost closed or partially blocked by foreign object	Adjusting the TXV does not affect the superheat or the suction pressure.	Adjust the TXV all the way in and out a few times to loosen it. Replace TXV if this does not work.
<b>Random Low Pressure trip (does not occur while there)</b>	Faulty compressor contactor	Points pitted or burned. Contactor sometimes sticks causing the compressor to run when it shouldn't, tripping the low pressure control.	Replace contactor.
	Intermittent Indoor circulator	Verify wiring is good.	Correct the wiring or replace the circulator.

go to TABLE OF CONTENTS

# Service Procedures



## A2L-SPECIFIC WARNING / INSTRUCTION

### Servicing a Unit with an **A2L** Refrigerant

#### 1. Work procedure

Work should be undertaken under a controlled procedure, for example according to an ordered checklist. This may be in contrast to how refrigeration service work has normally been performed in the past, and is to minimize the risk of flammable gas being present while the work is being performed .

#### 2. General work area

All maintenance staff and others working in the local area should be instructed on the nature of work being carried out. Work in confined spaces should be avoided.

#### 3. Checking for presence of refrigerant

The area should be checked with a refrigerant detector prior to and during work, to ensure the technician is aware of potentially oxygen-deprived or flammable atmospheres.

Ensure that the leak detection equipment being used is suitable for use with A2L refrigerants, i.e. non-sparking, and adequately sealed or intrinsically safe. Under no circumstances should a torch or flame be used in the searching for refrigerant leaks.

Electronic leak detectors may be used but for A2L's they may need re-calibration in a refrigerant-free area. Leak detection equipment should be set at a percentage of the LFL (lower flammability limit) of the refrigerant (25% maximum). The worst-case LFL for R454b is **0.296 kg/m<sup>3</sup>** or **11.3%** by volume.

Leak detection fluids are also suitable for use with most refrigerants but the use of detergents containing chlorine should be avoided as the chlorine can react with the refrigerant and corrode the copper pipe-work.

If a leak is suspected at any time, all naked flames should be removed/extinguished.

If a leakage of refrigerant is found which requires brazing, all of the refrigerant should be first recovered from the system, or isolated (by means of shut-off valves) in a part of the system remote from the leak.

#### 5. Presence of fire extinguisher

If any torch work (brazing) or refrigerant charging or removal is to be conducted, a dry powder or CO2 fire extinguisher should be ready at hand.

#### 6. No ignition sources

Sources of ignition should be eliminated in the vicinity of work being carried out on a system containing an A2L refrigerant. Prior to work taking place, the area around the equipment should be surveyed to make sure that there are no flammable hazards or ignition risks. "No Smoking" signs should be displayed .

#### 6. Ventilation of area

Ensure that the area is open to the outdoors or that it is adequately ventilated before breaking into the system or conducting any hot work. Ventilation should continue during the work, and can function to disperse any released refrigerant into a large space or preferably expel it into the outdoors.

#### 7. Checks of the refrigeration equipment

- The refrigerant charge is in accordance with the size of the room within which the system is installed.
- The ventilation equipment (if any) is operating adequately and is not obstructed.
- The water/glycol/pool water loop should be checked for the presence of refrigerant, which might show up with a refrigerant detector or by over-pressure in that loop.
- Equipment markings continue to be visible and legible. Illegible signs or markings should be corrected.
- Refrigeration piping is installed in a position where it is unlikely to be exposed to corrosive substances, unless the piping is constructed of materials which are inherently resistant to corrosion from that substance.

**A2L-SPECIFIC WARNING / INSTRUCTION****Servicing a Unit with an A2L Refrigerant (continued)****8. Checks to electrical devices & wiring**

Where electrical components are being changed, they should be as specified by Maritime Geothermal Ltd.. If in doubt, consult technical support for assistance.

Electrical components should be inspected. If a fault is found, electrical supply should not be connected to the circuit until the fault is rectified. If the fault cannot be corrected immediately but it is necessary to continue operation, an adequate temporary solution should be used. This should be reported to the owner of the equipment so all parties are advised.

Initial safety checks should include:

- Capacitors are discharged - this should be done in a safe manner to avoid possibility of sparking.
- No live electrical components and wiring are exposed while charging, recovering or purging the system.
- There is continuity of earth grounding/bonding.
- Check cabling for wear, corrosion, excessive pressure, vibration, sharp edges or any other adverse environmental effects. The check should take into account the effects of aging or continual vibration from sources such as compressors or fans.

**9. Refrigerant removal and circuit evacuation**

When breaking into the refrigerant circuit to make repairs - or for any other purpose - conventional procedures should be used. However, with flammable refrigerants it is important that best practice is followed:

- a) Safely remove refrigerant following local and national regulations, recovering into the correct recovery cylinders.
- b) Evacuate (vacuum). Ensure that the outlet of the vacuum pump is not close to any potential ignition sources and that ventilation is available.
- c) Purge the circuit by breaking the vacuum in the system with dry nitrogen and continuing to fill until the working pressure is achieved, then venting to atmosphere.
- d) Evacuate (vacuum) again, then vent to atmospheric pressure to enable work to take place.
- e) Open the circuit with torch, continuously flushing with dry nitrogen.

**10. Charging**

In addition to conventional charging procedures, the following should be observed.

- Ensure that contamination between different refrigerants does not occur when using charging equipment. Hoses should be as short as possible to minimize the amount of refrigerant contained in them.
- Cylinders should be kept in an appropriate position according to the instructions.
- Ensure that the refrigerating system is grounded prior to charging the system with refrigerant.
- Label the system when charging is complete (if final refrigerant charge is different from factory label).
- Extreme care should be taken not to over-charge the refrigerating system.

Prior to recharging the system, it should be pressure-tested with dry nitrogen. In addition, the system should be A2L leak-tested on completion of charging but prior to commissioning. A final A2L leak test should be carried out prior to leaving the site.

## ***Pumpdown Procedure***

1. Connect the refrigerant recovery unit to the heat pump's internal service ports via a refrigeration charging manifold and to a recovery tank as per the instructions in the recovery unit manual. Plan to dispose of refrigerant if there was a compressor burnout.
2. All refrigerant to water heat exchangers (brazed plates) **must either have full flow or be completely drained** of fluid before recovery begins. Failure to do so can freeze and rupture the heat exchanger, voiding its warranty.
3. Ensure all hose connections are properly purged of air. Start the refrigerant recovery as per the instructions in the recovery unit manual.
4. Allow the recovery unit suction pressure to reach a vacuum. Once achieved, close the charging manifold valves. Shut down, purge and disconnect the recovery unit as per the instructions in its manual. Ensure the recovery tank valve is closed before disconnecting the hose to it.
5. Connect a nitrogen tank to the charging manifold and add nitrogen to the heat pump until a positive gauge pressure of 5-10 psig is reached. This prevents air from being sucked into the unit by the vacuum when the hoses are disconnected.

The heat pump is now ready for repairs.

## ***General Repair Procedure***

1. Perform repairs to system.
  - Always ensure nitrogen is flowing through the system at the lowest flow rate that can be felt at the discharge during any brazing procedures to prevent soot buildup inside the pipes.
  - It is recommended to replace the liquid line filter-dryer any time the refrigeration system has been exposed to the atmosphere.
  - Place a wet rag around any valves being installed, as almost all valve types have non-metallic seats or seals that will be damaged by excessive heat, and aim the torch flame away from the valve body. Solder only one joint at a time and cool joints down in between.
2. Pressure test the system with nitrogen. It is recommended to check for leaks using leak detection spray, Spray Nine, or soapy water. Check at 10, 25, 50 and 100 psig. Allow the system to sit at 100 psig for at least an hour, then re-check.

## ***Vacuuming & Charging Procedure***

After completion of repairs and nitrogen pressure testing, the refrigeration circuit is ready for vacuuming.

1. Release the nitrogen pressure and connect the vacuum pump to the charging manifold. Start the vacuum pump and open the charging manifold valves. Vacuum until the vacuum gauge remains at less than 500 microns for at least 1 minute with the vacuum pump valve closed.
2. Close the charging manifold valves then shut off and disconnect the vacuum pump. Place a refrigerant tank with the proper refrigerant on a scale and connect it to the charging manifold. Purge the hose to the tank.
3. Weigh in the appropriate amount **and type** of refrigerant through the low pressure (suction) service port. Refer to the nameplate label on the unit for the proper refrigerant type and charge amount.
4. If the unit will not accept the entire charge, the remainder can be added through the low pressure service port after the unit has been restarted.

## Compressor Replacement Procedure

1. Pump down the unit as per the Pumpdown Procedure above. **If there was a compressor burn out (motor failure), the refrigerant cannot be reused and must be disposed of according to local codes.**
2. Disconnect piping.
3. Replace the compressor. Replace the liquid line filter-dryer. Always ensure nitrogen is flowing through the system at the lowest flow rate that can be felt at the discharge during any brazing procedures to prevent soot buildup inside the pipes.
4. Vacuum the unit as per above procedure.
5. If there was a compressor burnout:
  - a) Charge the unit with **new** refrigerant and operate it for continuously for 2 hours. Pump down the unit and replace the filter-dryer. Vacuum the unit as per above procedure.
  - b) Charge the unit (refrigerant can be re-used) and operate it for 2-3 days. Perform an acid test. If it fails, pump down the unit and replace the filter-dryer.
  - c) Charge the unit (refrigerant can be re-used) and operate it for 2 weeks. Perform and acid test. If it fails, pump down the unit and replace the filter-dryer.
5. Charge the unit a final time. Unit should now be clean and repeated future burn-outs can be avoided.

## Decommissioning

When the heat pump has reached the end of its useful lifetime after many years of service, it must be decommissioned.

Before carrying out this procedure, it is essential that the technician is completely familiar with the system and all its connected equipment. It is good practice that all refrigerants are recovered safely. Prior to the task being carried out, an oil and refrigerant sample should be taken in case analysis is required prior to re-use of recovered refrigerant. It is essential that electrical power is available before the task is commenced.

1. Examine all parts of the system to become familiar with the equipment and its operation.
2. Isolate system electrically.
3. Before starting the procedure, ensure that:
  - a) equipment is available for handling refrigerant and refrigerant cylinders.
  - b) recovery equipment and cylinders conform to the appropriate standards.
  - c) all personal protective equipment is available and being used correctly.
  - d) personnel are appropriately qualified.
4. Pump down refrigerant system.
5. If solenoid valves are closed and can't be powered open or there are other obstructions in the refrigeration system, make a manifold so that refrigerant can be removed from various parts of the system.
6. Make sure that the cylinder is situated on a scale before recovery takes place.
7. Start the recovery machine and operate in accordance with instructions.
8. Do not overfill cylinders (no more than 80 % volume liquid charge).
9. Do not exceed the maximum working pressure of the cylinder, even temporarily.
10. When all the refrigerant has been removed and the process completed, make sure that the cylinders and the equipment are removed from site promptly and all isolation valves on the equipment are closed off.
11. Recovered refrigerant should not be charged into another refrigerating system unless it has been checked and/or cleaned.

Equipment should be labelled stating that it has been de-commissioned and emptied of refrigerant. The label should be dated and signed.

Every effort should be made to check and **RE-USE** refrigerant and **RECYCLE** mechanical equipment.

# Model Specific Information



MODEL	lb	kg	Refrigerant	Oil Type
W-12	1.3	0.60	R454b	POE
W-18	1.5	0.68	R454b	POE

- In all cases the R454b charge per refrigeration circuit is below 'm1' in the UL/CSA 60335-2-40 standard, so unit is exempt from most special mechanical room measures associated with A2L refrigerants.  
 - **Refrigerant charge is subject to revision but always below m1;** actual charge is indicated on the unit nameplate.  
 - Oil capacity is marked on the compressor label.

MODEL	WEIGHT lb. (kg)	DIMENSIONS in (cm)		
		L	W	H
W-12	171 (78)	38 (97)	18 (46)	32 (81)
W-18	185 (84)	38 (97)	18 (46)	32 (81)

Loop	Mode	Parameter	(°F)	(°C)	Note
Indoor	Heating	Minimum ELT	50	10	Reduce flow if necessary during startup.
	Heating	Maximum LLT	120	49	
	Cooling	Minimum LLT	41	5	Water system (no antifreeze).
	Cooling	Minimum LLT	32	0	Antifreeze system. Adequate freeze protection required.
	Cooling	Maximum ELT	80	27	
Outdoor	Heating	Minimum ELT	39	4	Ground water (open loop) system.
	Heating	Minimum ELT	23	-5	Ground loop system. Adequate freeze protection required.
	Cooling	Minimum ELT	39	4	Ground water (open loop) system.
	Cooling	Minimum ELT	32	0	Ground loop system. Adequate freeze protection required.
	Cooling	Maximum LLT	120	49	

\* Values in this table are for rated liquid flow values.

MODEL	gpm	L/s
W-12	3	0.19
W-18	4.5	0.28

## Electrical Specifications (R454b)

TABLE 18	Code	Power Supply			Compressor		Circulators	FLA	MCA	Max. Breaker	Min. Wire
		V-ø-Hz	MIN	MAX	RLA	LRA	Max. A	Amps	Amps	Amps	ga
W-12	1	208/230-1-60	187	253	5.0	25	3.0	8.2	9.5	15	#14-2*
	3	265/277-1-60	226	304	4.0	21	3.0	7.2	8.2	15	#14-2
W-18	1	208/230-1-60	187	253	7.6	36	3.0	10.8	12.7	20	#12-2*
	3	265/277-1-60	226	304	5.8	27	3.0	9.0	10.5	15	#14-2

\* For 208/230-1-60, 1 additional conductor (neutral) is required if connecting 115VAC circulators to the unit.

go to TABLE OF CONTENTS

**Table 19: Loop Pressure Drop Data**

		INDOOR (water 104°F)		OUTDOOR (water 50°F)		OUTDOOR (15% methanol 32°F)		OUTDOOR (35% prop. glycol 32°F)		
		gpm	L/s	psi	kPa	psi	kPa	psi	kPa	psi
<b>W-12</b>	2	0.13	0.2	1.1	0.6	4	0.6	4	1.0	7
	2.5	0.16	0.2	1.6	0.8	5	0.9	6	1.4	10
	<b>3</b>	<b>0.19</b>	<b>0.3</b>	<b>2.2</b>	<b>1.1</b>	<b>8</b>	<b>1.2</b>	<b>8</b>	<b>1.8</b>	<b>13</b>
	3.5	0.22	0.4	2.9	1.5	10	1.6	11	2.2	15
	4	0.25	0.5	3.7	1.8	12	2.0	13	2.7	18
	4.5	0.28	0.7	4.6	2.3	16	2.5	17	3.4	23
	5	0.32	0.8	5.5	2.8	19	3.0	21	4.0	28
<b>W-18</b>	2.5	0.16	0.2	1.6	0.8	5	0.9	6	1.4	10
	3	0.19	0.3	2.2	1.1	8	1.2	8	1.8	13
	3.5	0.22	0.4	2.9	1.5	10	1.6	11	2.2	15
	4	0.25	0.5	3.7	1.8	12	2.0	13	2.7	18
	<b>4.5</b>	<b>0.28</b>	<b>0.7</b>	<b>4.6</b>	<b>2.3</b>	<b>16</b>	<b>2.5</b>	<b>17</b>	<b>3.4</b>	<b>23</b>
	5	0.32	0.8	5.5	2.8	19	3.0	21	4.0	28
	5.5	0.35	1.0	6.7	3.5	24	3.8	26	5.0	34

# Standard Capacity Ratings

Standards ARI/ISO/CSA 13256-2

Table 20 - Standard Capacity Ratings - <b>Ground Loop Heating*</b>						60Hz
EWT 104°F (40°C) * 15% Methanol by Weight Ground Loop Fluid					ELT 32°F (0°C)	
Model	Liquid Flow (Outdoor & Indoor)		Input Energy	Capacity		COP <sub>H</sub>
	gpm	L/s	Watts	Btu/hr	kW	W/W
W-12	3.0	0.19	756	7,800	2.3	3.02
W-18	4.5	0.28	1,183	12,100	3.5	3.00

Table 21 - Standard Capacity Ratings - <b>Ground Loop Cooling*</b>						60Hz	
EWT 53.6°F (12°C) * 15% Methanol by Weight Ground Loop Fluid					ELT 77°F (25°C)		
Model	Liquid Flow (Outdoor & Indoor)		Input Energy	Capacity		COP <sub>C</sub>	EER
	gpm	L/s	Watts	Btu/hr	kW	W/W	Btu/hr/W
W-12	3.0	0.19	680	9,800	2.9	4.22	14.4
W-18	4.5	0.28	1,029	14,500	4.3	4.13	14.1

Table 22 - Standard Capacity Ratings - <b>Ground Water Heating</b>						60Hz
EWT 104°F (40°C)					ELT 50°F (10°C)	
Model	Liquid Flow (Outdoor & Indoor)		Input Energy	Capacity		COP <sub>H</sub>
	gpm	L/s	Watts	Btu/hr	kW	W/W
W-12	3.0	0.19	812	10,700	3.1	3.86
W-18	4.5	0.28	1,263	16,500	4.8	3.83

Table 23 - Standard Capacity Ratings - <b>Ground Water Cooling</b>						60Hz	
EWT 53.6°F (12°C)					ELT 59°F (15°C)		
Model	Liquid Flow (Outdoor & Indoor)		Input Energy	Capacity		COP <sub>C</sub>	EER
	gpm	L/s	Watts	Btu/hr	kW	W/W	Btu/hr/W
W-12	3.0	0.19	523	10,400	3.0	5.83	19.9
W-18	4.5	0.28	844	16,300	4.8	5.66	19.3

# Performance Tables

W-12-HAC-X-\*L R454b, 60 Hz, KKN106

	OUTDOOR LOOP						ELECTRICAL		INDOOR LOOP						
	ELT (°F)	Evap. Temp.	Flow (gpm)	LLT (°F)	Delta T (°F)	Heat Abs. (Btu/hr)	Compressor Current (A)	Input Power (W)	EWT (°F)	Cond. Temp.	Flow (gpm)	LWT (°F)	Delta T (°F)	Heating (Btu/hr)	COP <sub>H</sub>
<b>HEATING</b>	25	15	3.0	22	-3.0	4,400	3.2	730	104	112	3.0	109	4.6	6,850	2.75
	30	20	3.0	27	-3.4	5,000	3.3	749		113	3.0	109	5.1	7,550	2.95
	35	24	3.0	31	-3.8	5,650	3.4	766		113	3.0	110	5.5	8,250	3.16
	40	29	3.0	36	-4.3	6,350	3.5	783		114	3.0	110	6.0	9,000	3.37
	45	34	3.0	40	-4.9	7,150	3.6	798		114	3.0	111	6.6	9,850	3.62
	50	39	3.0	45	-5.4	7,950	3.7	812		115	3.0	111	7.2	10,700	3.86
	55	43	3.0	49	-6.0	8,800	3.7	825		116	3.0	112	7.8	11,600	4.12
	60	48	3.0	53	-6.7	9,750	3.7	835		116	3.0	113	8.5	12,600	4.42
	25	15	3.0	22	-2.7	4,000	3.4	767	116	123	3.0	120	4.5	6,600	2.52
	30	20	3.0	27	-3.2	4,650	3.5	792	115	123	3.0		5.0	7,350	2.72
	35	25	3.0	31	-3.6	5,300	3.6	816	115	123	3.0		5.4	8,050	2.89
	40	30	3.0	36	-4.1	6,000	3.8	837	114	123	3.0		6.0	8,850	3.10
	45	35	3.0	40	-4.6	6,800	3.9	858	114	123	3.0		6.5	9,700	3.31
	50	39	3.0	45	-5.2	7,650	4.0	876	113	124	3.0		7.1	10,600	3.55
55	44	3.0	49	-5.9	8,550	4.0	893	112	124	3.0	7.8		11,600	3.81	
60	49	3.0	54	-6.5	9,550	4.1	907	112	124	3.0	8.5		12,600	4.07	

	ELT (°F)	Cond. Temp.	Flow (gpm)	LLT (°F)	Delta T (°F)	Heat Rej. (Btu/hr)	Compressor Current (A)	Input Power (W)	EWT (°F)	Evap. Temp.	Flow (gpm)	LWT (°F)	Delta T (°F)	Cooling (Btu/hr)	EER
	<b>COOLING</b>	60	79	3.0	68	8.3	12,150	2.5	533	54	39	3.0	47	-6.9	10,350
65		83	3.0	73	8.3	12,150	2.7	579	39		3.0	47	-6.8	10,200	17.6
70		88	3.0	78	8.3	12,100	2.8	623	40		3.0	47	-6.6	10,000	16.1
75		92	3.0	83	8.3	12,100	3.0	664	40		3.0	47	-6.5	9,850	14.8
80		97	3.0	88	8.3	12,050	3.2	705	41		3.0	47	-6.4	9,700	13.8
85		101	3.0	93	8.3	12,050	3.3	743	41		3.0	47	-6.4	9,550	12.9
90		106	3.0	98	8.3	12,050	3.5	783	42		3.0	47	-6.3	9,400	12.0
95		110	3.0	103	8.3	12,000	3.7	821	42		3.0	47	-6.2	9,250	11.3

METRIC

	OUTDOOR LOOP						ELECTRICAL		INDOOR LOOP						
	ELT (°C)	Evap. Temp.	Flow (L/s)	LLT (°C)	Delta T (°C)	Heat Abs. (kW)	Compressor Current (A)	Input Power (W)	EWT (°C)	Cond. Temp.	Flow (L/s)	LWT (°C)	Delta T (°C)	Heating (kW)	COP <sub>H</sub>
<b>HEATING (METRIC)</b>	-3.9	-9.5	0.19	-5.6	-1.7	1.29	3.2	730	40	44.6	0.19	42.6	2.6	2.01	2.75
	-1.1	-6.9	0.19	-3.0	-1.9	1.47	3.3	749		44.9	0.19	42.8	2.8	2.21	2.95
	1.7	-4.3	0.19	-0.4	-2.1	1.66	3.4	766		45.2	0.19	43.1	3.1	2.42	3.16
	4.4	-1.6	0.19	2.0	-2.4	1.86	3.5	783		45.5	0.19	43.3	3.3	2.64	3.37
	7.2	1.0	0.19	4.5	-2.7	2.10	3.6	798		45.8	0.19	43.7	3.7	2.89	3.62
	10.0	3.6	0.19	7.0	-3.0	2.33	3.7	812		46.1	0.19	44.0	4.0	3.14	3.86
	12.8	6.2	0.19	9.5	-3.3	2.58	3.7	825		46.4	0.19	44.3	4.3	3.40	4.12
	15.6	8.8	0.19	11.9	-3.7	2.86	3.7	835		46.7	0.19	44.7	4.7	3.69	4.42
	-3.9	-9.4	0.19	-5.4	-1.5	1.17	3.4	767	46.4	50.6	0.19	49	2.5	1.93	2.52
	-1.1	-6.7	0.19	-2.9	-1.8	1.36	3.5	792	46.1	50.7	0.19		2.8	2.15	2.72
	1.7	-4.0	0.19	-0.3	-2.0	1.55	3.6	816	45.9	50.7	0.19		3.0	2.36	2.89
	4.4	-1.3	0.19	2.1	-2.3	1.76	3.8	837	45.6	50.7	0.19		3.3	2.59	3.10
	7.2	1.4	0.19	4.6	-2.6	1.99	3.9	858	45.3	50.8	0.19		3.6	2.84	3.31
	10.0	4.1	0.19	7.1	-2.9	2.24	4.0	876	44.9	50.8	0.19		3.9	3.11	3.55
12.8	6.7	0.19	9.5	-3.3	2.51	4.0	893	44.6	50.9	0.19	4.3		3.40	3.81	
15.6	9.4	0.19	12.0	-3.6	2.80	4.1	907	44.2	50.9	0.19	4.7		3.69	4.07	

	ELT (°C)	Cond. Temp.	Flow (L/s)	LLT (°C)	Delta T (°C)	Heat Rej. (kW)	Compressor Current (A)	Input Power (W)	EWT (°C)	Evap. Temp.	Flow (L/s)	LWT (°C)	Delta T (°C)	Cooling (kW)	COP <sub>C</sub>
	<b>COOLING (METRIC)</b>	15.6	26	0.19	20.2	4.6	3.56	2.5	533	12	4	0.19	8.2	-3.8	3.03
18.3		29	0.19	22.9	4.6	3.56	2.7	579	4		0.19	8.2	-3.8	2.99	5.16
21.1		31	0.19	25.7	4.6	3.55	2.8	623	4		0.19	8.3	-3.7	2.93	4.72
23.9		33	0.19	28.5	4.6	3.55	3.0	664	5		0.19	8.4	-3.6	2.89	4.34
26.7		36	0.19	31.3	4.6	3.53	3.2	705	5		0.19	8.4	-3.6	2.84	4.04
29.4		38	0.19	34.0	4.6	3.53	3.3	743	5		0.19	8.4	-3.6	2.80	3.78
32.2		41	0.19	36.8	4.6	3.53	3.5	783	5		0.19	8.5	-3.5	2.75	3.52
35.0		43	0.19	39.6	4.6	3.52	3.7	821	6		0.19	8.6	-3.4	2.71	3.31

go to TABLE OF CONTENTS

# Performance Tables (continued)

W-18-HAC-P-\*L R454b, 60 Hz, KKN156

	OUTDOOR LOOP						ELECTRICAL		INDOOR LOOP						
	ELT (°F)	Evap. Temp.	Flow (gpm)	LLT (°F)	Delta T (°F)	Heat Abs. (Btu/hr)	Compressor Current (A)	Input Power (W)	EWT (°F)	Cond. Temp.	Flow (gpm)	LWT (°F)	Delta T (°F)	Heating (Btu/hr)	COP <sub>H</sub>
<b>HEATING</b>	25	14	4.5	22	-3.1	6,800	4.7	1,144	104	112	4.5	109	4.8	10,650	2.73
	30	19	4.5	27	-3.5	7,750	4.9	1,173		113	4.5	109	5.2	11,700	2.92
	35	24	4.5	31	-4.0	8,750	5.1	1,199		113	4.5	110	5.7	12,750	3.12
	40	29	4.5	36	-4.5	9,850	5.3	1,223		114	4.5	110	6.2	13,950	3.34
	45	33	4.5	40	-5.0	11,000	5.4	1,244		114	4.5	111	6.8	15,200	3.58
	50	38	4.5	44	-5.6	12,250	5.5	1,263		115	4.5	111	7.4	16,500	3.83
	55	43	4.5	49	-6.2	13,600	5.6	1,279		116	4.5	112	8.0	17,900	4.10
	60	47	4.5	53	-6.9	15,000	5.7	1,291		116	4.5	113	8.7	19,350	4.39
	25	15	4.5	22	-2.9	6,300	5.0	1,209	115	123	4.5	120	4.7	10,350	2.51
	30	20	4.5	27	-3.3	7,200	5.2	1,243	115	123	4.5		5.1	11,350	2.68
	35	24	4.5	31	-3.7	8,200	5.4	1,274	114	123	4.5		5.6	12,500	2.88
	40	29	4.5	36	-4.2	9,250	5.6	1,302	114	123	4.5		6.1	13,600	3.06
	45	34	4.5	40	-4.7	10,400	5.7	1,327	113	123	4.5		6.7	14,850	3.28
	50	39	4.5	45	-5.3	11,650	5.9	1,349	113	123	4.5		7.3	16,200	3.52
55	44	4.5	49	-5.9	13,000	6.0	1,368	112	123	4.5	7.9		17,600	3.77	
60	49	4.5	53	-6.6	14,450	6.0	1,382	111	123	4.5	8.6		19,100	4.05	

	ELT (°F)	Cond. Temp.	Flow (gpm)	LLT (°F)	Delta T (°F)	Heat Rej. (Btu/hr)	Compressor Current (A)	Input Power (W)	EWT (°F)	Evap. Temp.	Flow (gpm)	LWT (°F)	Delta T (°F)	Cooling (Btu/hr)	EER
	<b>COOLING</b>	60	77	4.5	69	8.7	19,050	3.7	860	54	39	4.5	46	-7.2	16,150
65		82	4.5	74	8.6	18,750	4.0	923	39		4.5	47	-7.0	15,650	17.0
70		88	4.5	78	8.4	18,400	4.2	975	40		4.5	47	-6.7	15,150	15.5
75		93	4.5	83	8.3	18,100	4.4	1,015	40		4.5	47	-6.5	14,700	14.5
80		98	4.5	88	8.2	17,750	4.5	1,047	41		4.5	47	-6.3	14,250	13.6
85		103	4.5	93	8.0	17,400	4.6	1,071	41		4.5	48	-6.1	13,800	12.9
90		109	4.5	98	7.8	17,000	4.7	1,092	42		4.5	48	-5.9	13,350	12.2
95		114	4.5	103	7.7	16,600	4.8	1,109	43		4.5	48	-5.7	12,850	11.6

METRIC

	OUTDOOR LOOP						ELECTRICAL		INDOOR LOOP						
	ELT (°C)	Evap. Temp.	Flow (L/s)	LLT (°C)	Delta T (°C)	Heat Abs. (kW)	Compressor Current (A)	Input Power (W)	EWT (°C)	Cond. Temp.	Flow (L/s)	LWT (°C)	Delta T (°C)	Heating (kW)	COP <sub>H</sub>
<b>HEATING (METRIC)</b>	-3.9	-9.8	0.28	-5.6	-1.7	1.99	4.7	1,144	40	44.6	0.28	42.7	2.7	3.12	2.73
	-1.1	-7.2	0.28	-3.0	-1.9	2.27	4.9	1,173		44.9	0.28	42.9	2.9	3.43	2.92
	1.7	-4.6	0.28	-0.5	-2.2	2.56	5.1	1,199		45.2	0.28	43.2	3.2	3.74	3.12
	4.4	-1.9	0.28	1.9	-2.5	2.89	5.3	1,223		45.5	0.28	43.4	3.4	4.09	3.34
	7.2	0.7	0.28	4.4	-2.8	3.22	5.4	1,244		45.8	0.28	43.8	3.8	4.45	3.58
	10.0	3.3	0.28	6.9	-3.1	3.59	5.5	1,263		46.1	0.28	44.1	4.1	4.84	3.83
	12.8	5.9	0.28	9.4	-3.4	3.99	5.6	1,279		46.4	0.28	44.4	4.4	5.25	4.10
	15.6	8.6	0.28	11.8	-3.8	4.40	5.7	1,291		46.7	0.28	44.8	4.8	5.67	4.39
	-3.9	-9.7	0.28	-5.5	-1.6	1.85	5.0	1,209		46.3	50.4	0.28	49	2.6	3.03
	-1.1	-6.9	0.28	-2.9	-1.8	2.11	5.2	1,243	46.1	50.5	0.28	2.8		3.33	2.68
	1.7	-4.3	0.28	-0.4	-2.1	2.40	5.4	1,274	45.8	50.6	0.28	3.1		3.66	2.88
	4.4	-1.6	0.28	2.1	-2.3	2.71	5.6	1,302	45.5	50.6	0.28	3.4		3.99	3.06
	7.2	1.1	0.28	4.6	-2.6	3.05	5.7	1,327	45.2	50.6	0.28	3.7		4.35	3.28
	10.0	3.8	0.28	7.1	-2.9	3.41	5.9	1,349	44.8	50.7	0.28	4.1		4.75	3.52
	12.8	6.4	0.28	9.5	-3.3	3.81	6.0	1,368	44.5	50.7	0.28	4.4		5.16	3.77
	15.6	9.2	0.28	11.9	-3.7	4.23	6.0	1,382	44.1	50.8	0.28	4.8		5.60	4.05

	ELT (°C)	Cond. Temp.	Flow (L/s)	LLT (°C)	Delta T (°C)	Heat Rej. (kW)	Compressor Current (A)	Input Power (W)	EWT (°C)	Evap. Temp.	Flow (L/s)	LWT (°C)	Delta T (°C)	Cooling (kW)	COP <sub>c</sub>
	<b>COOLING (METRIC)</b>	15.6	25	0.28	20.4	4.8	5.58	3.7	860	12	4	0.28	8.0	-4.0	4.73
18.3		28	0.28	23.1	4.8	5.50	4.0	923	4		0.28	8.1	-3.9	4.59	4.98
21.1		31	0.28	25.8	4.7	5.39	4.2	975	4		0.28	8.3	-3.7	4.44	4.54
23.9		34	0.28	28.5	4.6	5.30	4.4	1,015	5		0.28	8.4	-3.6	4.31	4.25
26.7		37	0.28	31.3	4.6	5.20	4.5	1,047	5		0.28	8.5	-3.5	4.18	3.99
29.4		40	0.28	33.8	4.4	5.10	4.6	1,071	5		0.28	8.6	-3.4	4.04	3.78
32.2		43	0.28	36.5	4.3	4.98	4.7	1,092	6		0.28	8.7	-3.3	3.91	3.58
35.0		46	0.28	39.3	4.3	4.86	4.8	1,109	6		0.28	8.8	-3.2	3.77	3.40

go to TABLE OF CONTENTS

# W-HAC Schematic Diagram

208/230-1-60, Rotary Compressor

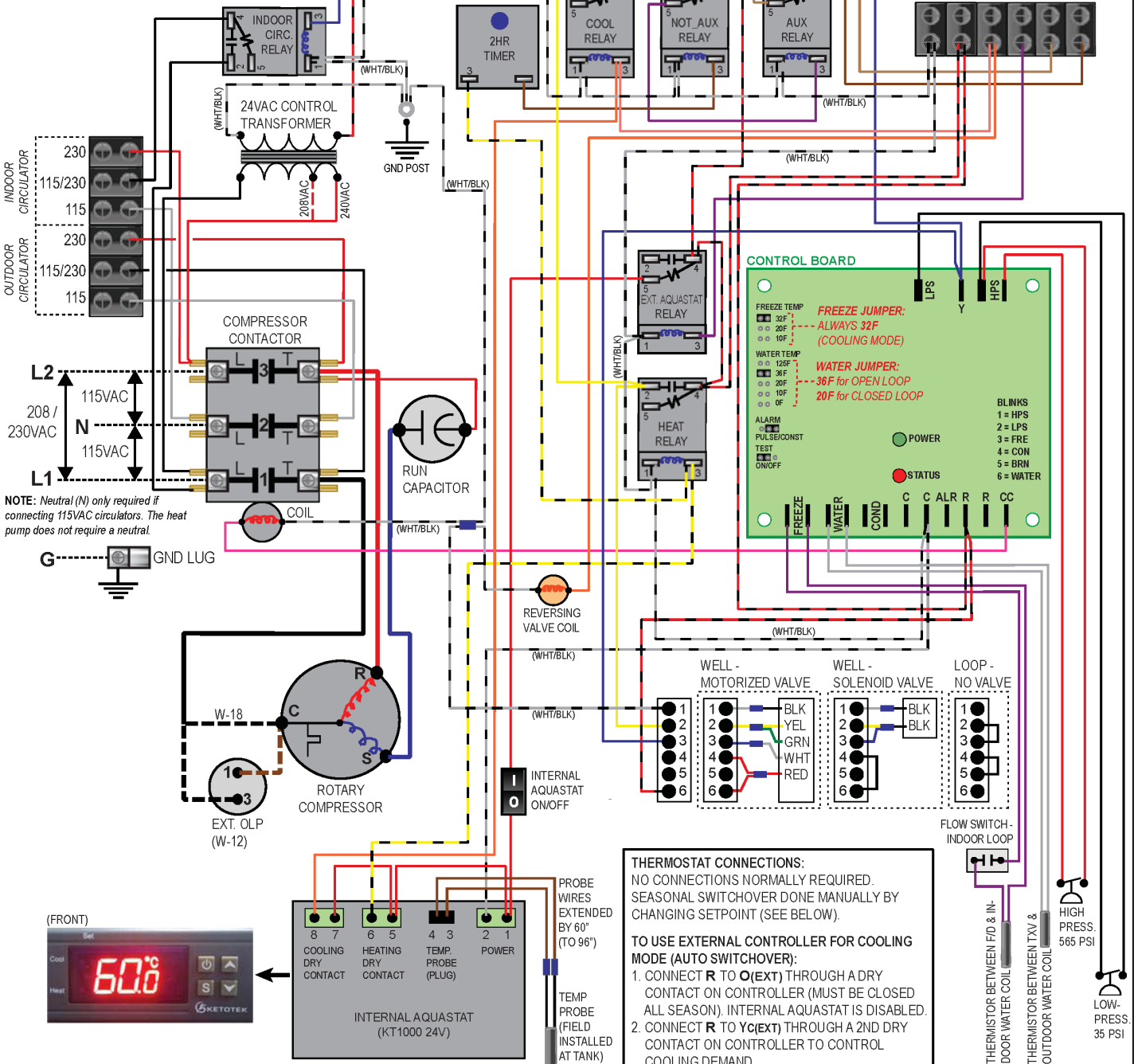

### AQUASTAT OPERATION:

- PRESS THE UP ARROW TO CHECK THE WATER TEMPERATURE SETPOINT.
- PRESS THE DOWN ARROW TO CHECK THE TEMPERATURE DIFFERENTIAL.

HEAT PUMP WILL OPERATE IN HEATING MODE WHEN TANK TEMPERATURE FALLS BELOW SETPOINT BY DIFFERENTIAL, AND WILL OPERATE IN COOLING MODE WHEN TANK TEMPERATURE RISES ABOVE SETPOINT BY DIFFERENTIAL.

WHEN ON/OFF SWITCH IS IN OFF (0) POSITION (OR EXTERNAL COOLING CONTROLLER IS CONNECTED AND ACTIVE), AQUASTAT DISPLAY WILL TURN OFF AND AQUASTAT WILL NOT FUNCTION. SETTINGS WILL BE RETAINED.

### TO CHANGE SETTINGS:

1. PRESS AND HOLD THE S BUTTON FOR 3 SECONDS.
2. USE ARROW KEYS TO SELECT F1 FOR SETPOINT OR F2 FOR DIFFERENTIAL.
3. PRESS S TO DISPLAY CURRENT VALUE. TO CHANGE PRESS & HOLD S WHILE SIMULTANEOUSLY PRESSING AN ARROW KEY. PRESS U TO SAVE SETTING.

### TO SWITCH FROM HEATING TO COOLING MODE:

USE STEPS 1-3 ABOVE TO CHANGE SETPOINT (F1) FROM HEATING VALUE OF 90-120°F (32-49°C) TO COOLING VALUE OF 45-50°F (7-10°C).

03	000349	D. RHEAULT	D. RHEAULT	22-JUN-2026	Drawn By D. RHEAULT	Date 1-FEB-2019	<b>MARITIME GEOTHERMAL LTD.</b> P.O. Box 2555 170 Plantation Rd. Pettitcodiac, NB CANADA E4Z 6H4
02	ISSUE 02	D. RHEAULT	D. RHEAULT	18-NOV-2024	Checked By D. RHEAULT	Date 1-FEB-2019	
02	000317	D. RHEAULT	D. RHEAULT	4-AUG-2023	Eng. Approved By	Date	
01	Init. Re-Release	D. RHEAULT	D. RHEAULT	2-MAY-2022	Mfg. Approved By	Date	
REV	ECO#	IMPL BY	APVD BY	DATE	Approved By	Date	

Drawing Name		Drawing Rev		Sheet	
W-**-HAC-*-1L-** Schematic Diagram		03		1 / 1	
Size	Drawing Number	Drawing Rev		Sheet	
LET	002380SCH	03		1 / 1	

90 to TABLE OF CONTENTS

# W-HAC Schematic Diagram

265/277-1-60, Rotary Compressor

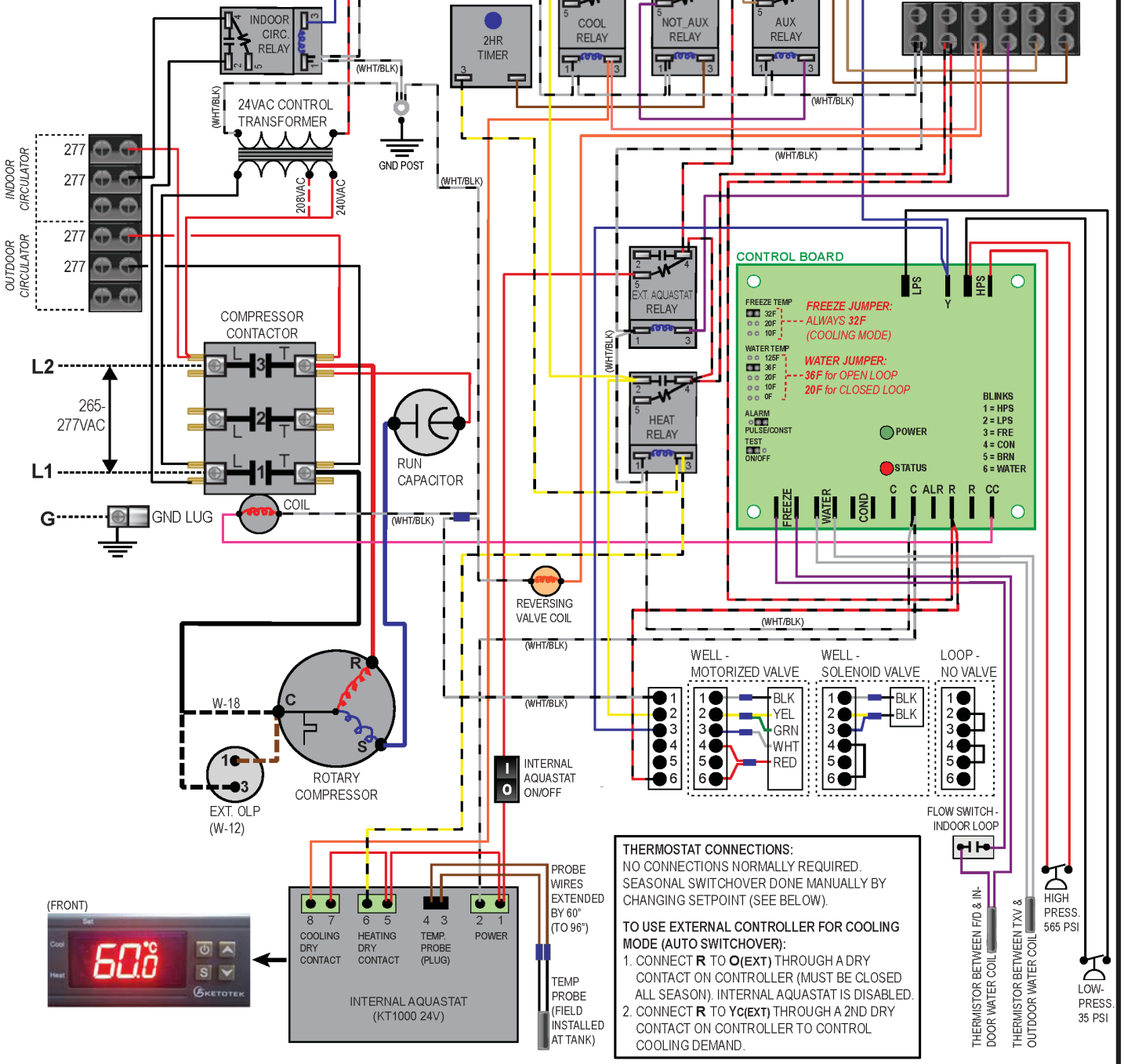

**THERMOSTAT CONNECTIONS:**  
 NO CONNECTIONS NORMALLY REQUIRED. SEASONAL SWITCHOVER DONE MANUALLY BY CHANGING SETPOINT (SEE BELOW).

**TO USE EXTERNAL CONTROLLER FOR COOLING MODE (AUTO SWITCHOVER):**  
 1. CONNECT **R** TO **O(EXT)** THROUGH A DRY CONTACT ON CONTROLLER (MUST BE CLOSED ALL SEASON). INTERNAL AQUASTAT IS DISABLED.  
 2. CONNECT **R** TO **Yc(EXT)** THROUGH A 2ND DRY CONTACT ON CONTROLLER TO CONTROL COOLING DEMAND.

**AQUASTAT OPERATION:**  
 - PRESS THE **UP** ARROW TO CHECK THE WATER TEMPERATURE SETPOINT.  
 - PRESS THE **DOWN** ARROW TO CHECK THE TEMPERATURE DIFFERENTIAL.

HEAT PUMP WILL OPERATE IN **HEATING** MODE WHEN TANK TEMPERATURE **FALLS BELOW** SETPOINT BY DIFFERENTIAL, AND WILL OPERATE IN **COOLING** MODE WHEN TANK TEMPERATURE **RISES ABOVE** SETPOINT BY DIFFERENTIAL.

WHEN **ON/OFF SWITCH** IS IN **OFF (0)** POSITION (OR EXTERNAL COOLING CONTROLLER IS CONNECTED AND ACTIVE), AQUASTAT DISPLAY WILL TURN OFF AND AQUASTAT WILL NOT FUNCTION. SETTINGS WILL BE RETAINED.

**TO CHANGE SETTINGS:**  
 1. PRESS AND HOLD THE **S** BUTTON FOR 3 SECONDS.  
 2. USE ARROW KEYS TO SELECT **F1** FOR SETPOINT OR **F2** FOR DIFFERENTIAL.  
 3. PRESS **S** TO DISPLAY CURRENT VALUE. TO CHANGE PRESS & HOLD **S** WHILE SIMULTANEOUSLY PRESSING AN ARROW KEY. PRESS **U** TO SAVE SETTING.

**TO SWITCH FROM HEATING TO COOLING MODE:**  
 USE STEPS 1-3 ABOVE TO CHANGE SETPOINT (F1) FROM HEATING VALUE OF 90-120°F (32-49°C) TO COOLING VALUE OF 45-50°F (7-10°C).

03	000349	D. RHEAULT	D. RHEAULT	22-JUN-2026	Drawn By <b>D. RHEAULT</b> Date <b>24-APR-2019</b> Checked By <b>D. RHEAULT</b> Date <b>24-APR-2019</b> Eng. Approved By Date Mfg. Approved By Date Approved By Date	<b>MARITIME GEOTHERMAL LTD.</b> P.O. Box 2555 170 Plantation Rd. Pettitcodiac, NB CANADA E4Z 6H4	Drawing Name			
02	ISSUE 02	D. RHEAULT	D. RHEAULT	18-NOV-2024			W-**-HAC-**-3L-** Schematic Diagram			
02	000317	D. RHEAULT	D. RHEAULT	4-AUG-2023			Size	Drawing Number	Drawing Rev	Sheet
01	Init. Re-Release	D. RHEAULT	D. RHEAULT	2-MAY-2022			LET	002383SCH	03	1 / 1
REV	ECO#	IMPL BY	APVD BY	DATE						

### W-HAC Heating Mode

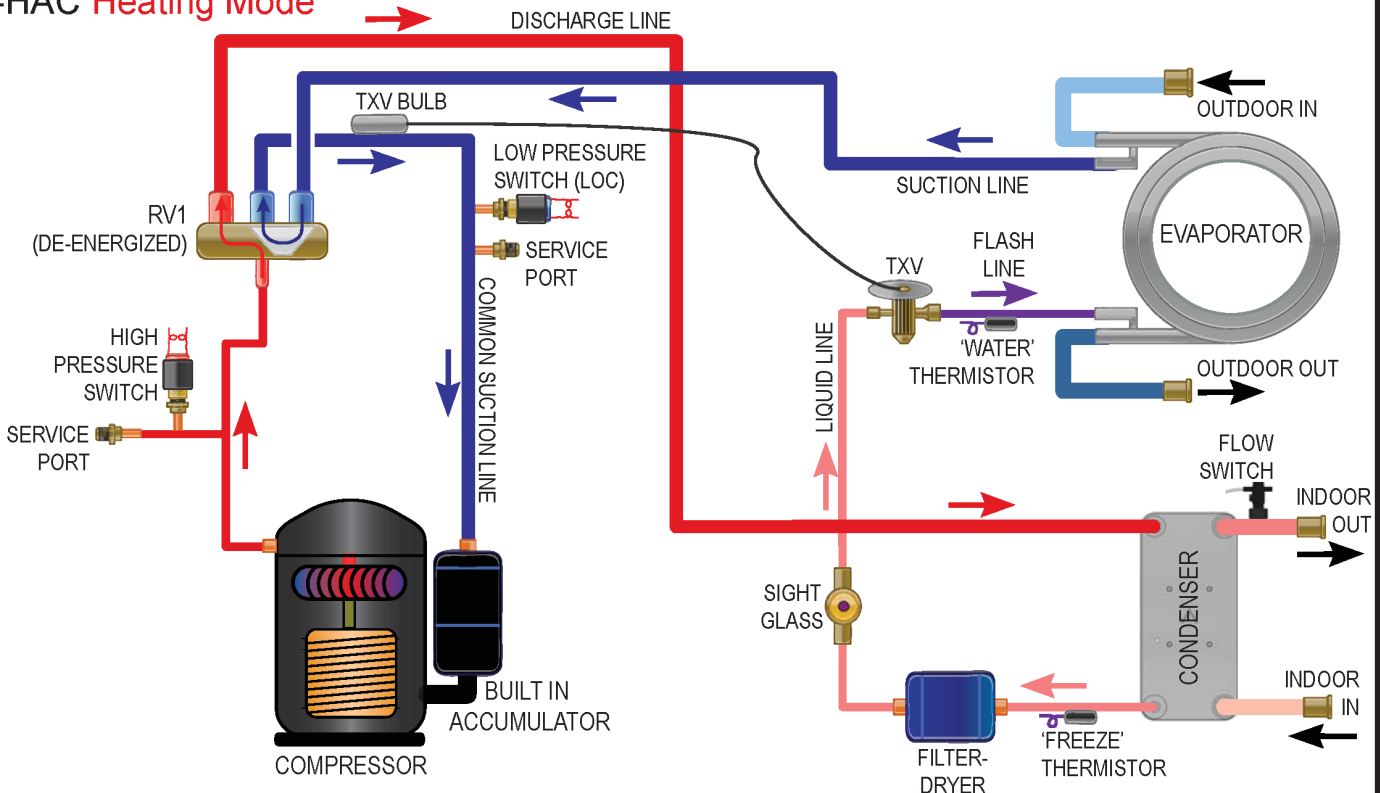

### W-HAC Cooling Mode

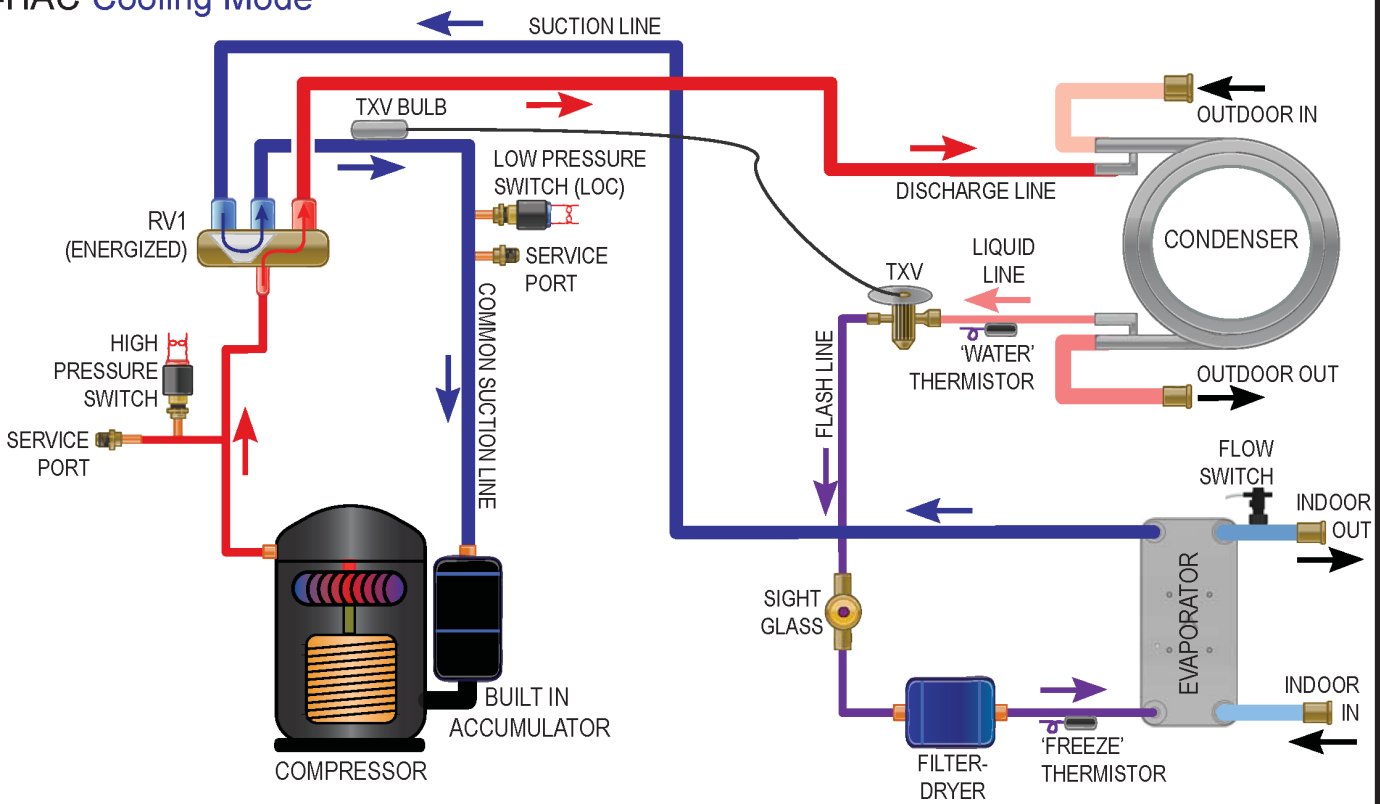

				Drawn By D. RHEAULT	Date 22-JUN-2026	<b>MARITIME GEOTHERMAL LTD.</b> P.O. Box 2555 170 Plantation Rd. Petitcodiac, NB CANADA E4Z 6H4
				Checked By D. RHEAULT	Date 22-JUN-2026	
				Eng. Approved By	Date	
				Mfg. Approved By	Date	
01	Initial Release	D. RHEAULT	D. RHEAULT	22-JUN-2026	Drawing Name W-HAC Refrigeration Circuit	
REV	ECO#	IMPL BY	APVD BY	DATE	Approved By	Date
				Size LET	Drawing Number 003104RCD	Drawing Revision 01
						Sheet 1 / 1

go to TABLE OF CONTENTS

# Dimensions

RECOMMENDED FRONT CLEARANCE:  
**2 FT**

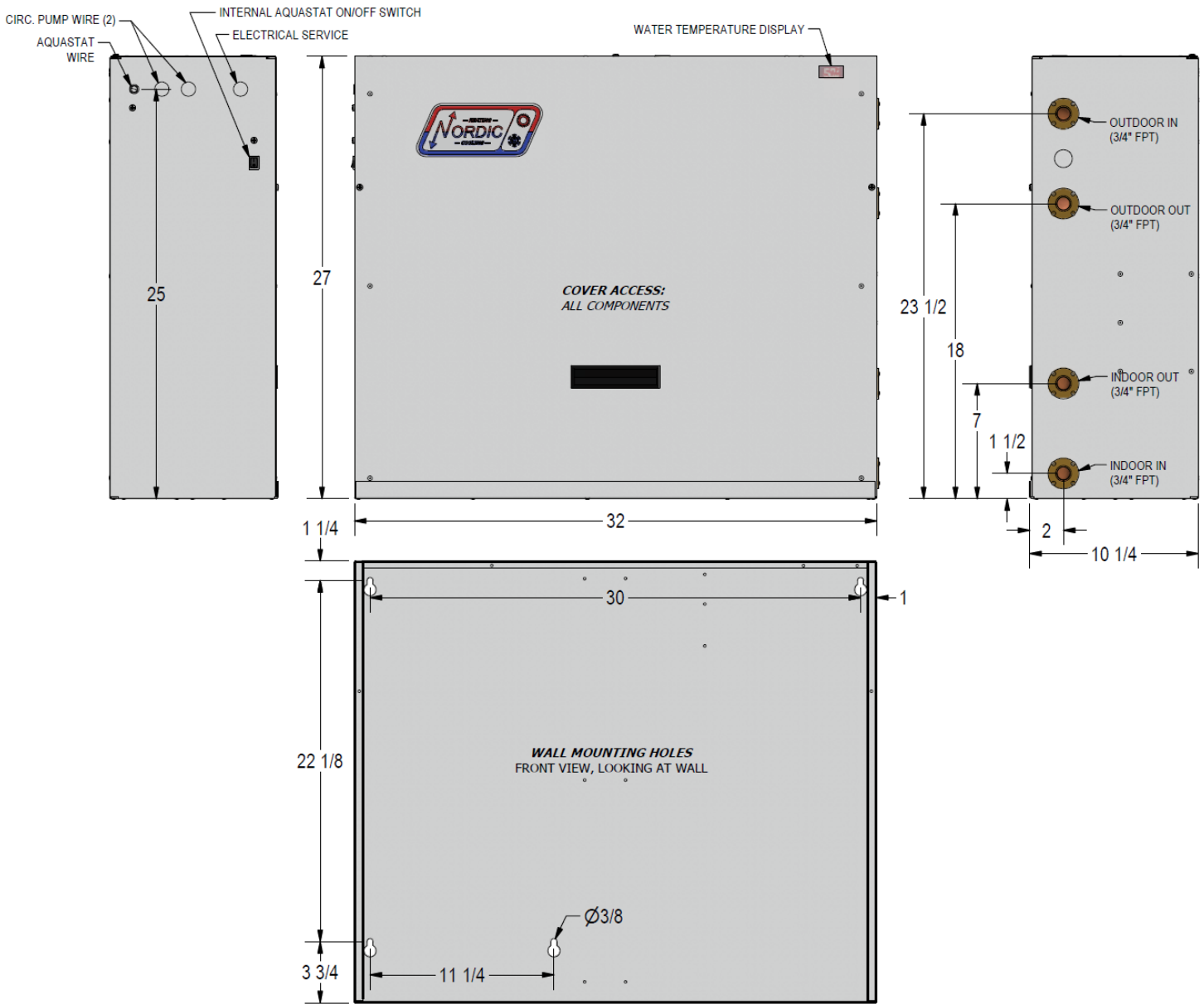

NO BACK OR SIDE CLEARANCES REQUIRED

# LIMITED RESIDENTIAL WARRANTY

MARITIME GEOTHERMAL LTD. warrants that the heat pumps manufactured by it shall be free from defects in materials and workmanship for a period of (5) FIVE YEARS after the date of installation or for a period of (5) FIVE YEARS AND (60) SIXTY DAYS after the date of shipment, whichever occurs first. In addition MARITIME GEOTHERMAL LTD. warrants that the compressor shall be free of defects in materials and workmanship for an additional period of (2) TWO YEARS from said date.

MARITIME GEOTHERMAL LTD. shall, at its option repair or replace any part or parts covered by this warranty which shall be returned to MARITIME GEOTHERMAL LTD., transportation charges prepaid, which, upon examination proves to be defective in materials or workmanship. Replacement or repaired parts and components are warranted only for the remaining portion of the original warranty period.

This warranty is subject to the following conditions:

1. The NORDIC® heat pump must be properly installed and maintained in accordance with MARITIME GEOTHERMAL LTD.'s installation and maintenance instructions.
2. The installer must complete the “**Installation Data Sheet**”, have it endorsed by the owner and return it to Maritime Geothermal Ltd. within 21 days of installation of the unit.
3. It is the responsibility of the building or general contractor to supply temporary heat to the structure prior to occupancy. These heat pumps are designed to provide heat only to the completely finished and insulated structure. Start-up of the unit shall not be scheduled prior to completion of construction and final duct installation for validation of this warranty.
4. It is the customer's responsibility to supply the proper quantity and quality of water.

If the heat pump, manufactured by MARITIME GEOTHERMAL LTD., fails to conform to this warranty, MARITIME GEOTHERMAL LTD.'s sole and exclusive liability shall be, at its option, to repair or replace any part or component which is returned by the customer during the applicable warranty period set forth above, provided that (1) MARITIME GEOTHERMAL LTD. is promptly notified in writing upon discovery by the customer that such part or component fails to conform to this warranty. (2) The customer returns such part or component to MARITIME GEOTHERMAL LTD., transportation charges prepaid, within (30) thirty days of failure, and (3) MARITIME GEOTHERMAL LTD.'s examination of such component shall disclose to its satisfaction that such part or component fails to meet this warranty and the alleged defects were not caused by accident, misuse, neglect, alteration, improper installation, repair or improper testing.



# RESIDENTIAL WARRANTY REGISTRATION

(A PRINTED COPY OF THIS FORM IS SHIPPED WITH THE UNIT.)

Complete all fields to have your warranty effective as of the install date. Should this form not be completed or if it does not include sufficient detail, warranty will be effective as of the date your unit was shipped from Maritime Geothermal Ltd..

**Model:** \_\_\_\_\_

**Serial Number:** \_\_\_\_\_

**Install Date:** \_\_\_\_\_

**Installed By:** \_\_\_\_\_  
(company name)

**Loop Type:**  horizontal  vertical  open  pond  
(geothermal only)

**Installation Type:**  new construction  replacement/retrofit

**Address of installation:** \_\_\_\_\_

**City:** \_\_\_\_\_

**Province / State:** \_\_\_\_\_

**Postal Code / Zip:** \_\_\_\_\_

Where do I find my model and serial number?

There is a label on the outside of your unit like this one.

**MARITIME GEOTHERMAL LTD.**  
Manufacturer of Geothermal Heat Pumps

**Model** R-55-HACW-X-1T-C-SDELF-01

**Serial #** xxxxx - xx - xx **Volts:** 230 **Ph:** 1 **Hz:** 60

Compressor	Fan Motor	External Pump
RLA: 18.3	FLA: 4.0	Max. Amps: 5.0
LRA: 138	HP: 1	

**Min. Ampacity:** 32.7 A **Max. Circuit Breaker:** 50 A

**Refrigerant:** R454b **Qty:** 3.6 kg 8.0 lb

Design Pressures: 2100 kPa (300 psig) Low Side / 4000 kPa (580 psig) High Side  
Ingress Protection: IPX1

001091FRM-06